

# The catalogue of types of geometric neighbors over four variables

Jiří Vomlel and Milan Studený

April 27, 2010



# Contents

<b>0</b>	<b>Degree difference 0</b>	<b>13</b>
0.4	Squared Euclidean length 4 . . . . .	13
0.4.4	Number of nonzero values 4 . . . . .	13
0.4.4.1	Differential imset (1) . . . . .	13
0.4.4.2	Differential imset (2) . . . . .	15
0.4.4.3	Differential imset (3) . . . . .	17
0.4.4.4	Differential imset (4) . . . . .	19
0.6	Squared Euclidean length 6 . . . . .	20
0.6.6	Number of nonzero values 6 . . . . .	20
0.6.6.1	Differential imset (5) . . . . .	20
0.6.6.2	Differential imset (6) . . . . .	21
0.6.6.3	Differential imset (7) . . . . .	22
0.6.6.4	Differential imset (8) . . . . .	23
0.6.6.5	Differential imset (9) . . . . .	24
0.6.6.6	Differential imset (10) . . . . .	25
0.6.6.7	Differential imset (11) . . . . .	27
0.6.6.8	Differential imset (12) . . . . .	28
0.8	Squared Euclidean length 8 . . . . .	29
0.8.8	Number of nonzero values 8 . . . . .	29
0.8.8.1	Differential imset (13) . . . . .	29
0.8.8.2	Differential imset (14) . . . . .	31
0.8.8.3	Differential imset (15) . . . . .	32
0.8.8.4	Differential imset (16) . . . . .	33
0.8.8.5	Differential imset (17) . . . . .	35
0.8.8.6	Differential imset (18) . . . . .	36
0.8.8.7	Differential imset (19) . . . . .	38
0.8.8.8	Differential imset (20) . . . . .	39
0.8.8.9	Differential imset (21) . . . . .	40
0.8.8.10	Differential imset (22) . . . . .	41
0.10	Squared Euclidean length 10 . . . . .	42
0.10.7	Number of nonzero values 7 . . . . .	42
0.10.7.1	Differential imset (23) . . . . .	42
0.10.7.2	Differential imset (24) . . . . .	43
0.10.7.3	Differential imset (25) . . . . .	44
0.10.7.4	Differential imset (26) . . . . .	45
0.10.7.5	Differential imset (27) . . . . .	46
0.10.7.6	Differential imset (28) . . . . .	47
0.10.7.7	Differential imset (29) . . . . .	48
0.10.7.8	Differential imset (30) . . . . .	49
0.10.7.9	Differential imset (31) . . . . .	50
0.10.7.10	Differential imset (32) . . . . .	51
0.10.7.11	Differential imset (33) . . . . .	52
0.10.7.12	Differential imset (34) . . . . .	53
0.10.7.13	Differential imset (35) . . . . .	54
0.10.7.14	Differential imset (36) . . . . .	55
0.10.10	Number of nonzero values 10 . . . . .	56
0.10.10.1	Differential imset (37) . . . . .	56
0.10.10.2	Differential imset (38) . . . . .	57
0.10.10.3	Differential imset (39) . . . . .	58

0.10.10.4	Differential imset (40)	59
0.10.10.5	Differential imset (41)	60
0.10.10.6	Differential imset (42)	61
0.10.10.7	Differential imset (43)	62
0.10.10.8	Differential imset (44)	63
0.10.10.9	Differential imset (45)	64
0.12	Squared Euclidean length 12	65
0.12.6	Number of nonzero values 6	65
0.12.6.1	Differential imset (46)	65
0.12.6.2	Differential imset (47)	67
0.12.6.3	Differential imset (48)	68
0.12.6.4	Differential imset (49)	69
0.12.6.5	Differential imset (50)	70
0.12.9	Number of nonzero values 9	71
0.12.9.1	Differential imset (51)	71
0.12.9.2	Differential imset (52)	72
0.12.9.3	Differential imset (53)	73
0.12.9.4	Differential imset (54)	74
0.12.9.5	Differential imset (55)	75
0.12.9.6	Differential imset (56)	76
0.12.9.7	Differential imset (57)	77
0.12.9.8	Differential imset (58)	78
0.12.9.9	Differential imset (59)	79
0.12.9.10	Differential imset (60)	80
0.12.9.11	Differential imset (61)	81
0.12.9.12	Differential imset (62)	82
0.12.12	Number of nonzero values 12	83
0.12.12.1	Differential imset (63)	83
0.12.12.2	Differential imset (64)	84
0.14	Squared Euclidean length 14	85
0.14.8	Number of nonzero values 8	85
0.14.8.1	Differential imset (65)	85
0.14.8.2	Differential imset (66)	86
0.14.8.3	Differential imset (67)	87
0.14.8.4	Differential imset (68)	88
0.14.8.5	Differential imset (69)	89
0.14.8.6	Differential imset (70)	90
0.14.8.7	Differential imset (71)	91
0.14.8.8	Differential imset (72)	92
0.14.8.9	Differential imset (73)	93
0.14.8.10	Differential imset (74)	94
0.14.8.11	Differential imset (75)	95
0.14.8.12	Differential imset (76)	96
0.14.11	Number of nonzero values 11	97
0.14.11.1	Differential imset (77)	97
0.14.11.2	Differential imset (78)	98
0.16	Squared Euclidean length 16	99
0.16.10	Number of nonzero values 10	99
0.16.10.1	Differential imset (79)	99
0.16.10.2	Differential imset (80)	100
0.16.10.3	Differential imset (81)	101
0.16.10.4	Differential imset (82)	102
0.18	Squared Euclidean length 18	103
0.18.7	Number of nonzero values 7	103
0.18.7.1	Differential imset (83)	103
0.18.7.2	Differential imset (84)	104
0.18.9	Number of nonzero values 9	105
0.18.9.1	Differential imset (85)	105
0.18.9.2	Differential imset (86)	106
0.18.9.3	Differential imset (87)	107
0.20	Squared Euclidean length 20	108

0.20.9	Number of nonzero values 9 . . . . .	108
0.20.9.1	Differential imset (88) . . . . .	108

**1 Degree difference 1 109**

1.4	Squared Euclidean length 4 . . . . .	109
1.4.4	Number of nonzero values 4 . . . . .	109
1.4.4.1	Differential imset (89) . . . . .	109
1.4.4.2	Differential imset (90) . . . . .	113
1.4.4.3	Differential imset (91) . . . . .	115
1.4.4.4	Differential imset (92) . . . . .	118
1.6	Squared Euclidean length 6 . . . . .	121
1.6.6	Number of nonzero values 6 . . . . .	121
1.6.6.1	Differential imset (93) . . . . .	121
1.6.6.2	Differential imset (94) . . . . .	122
1.6.6.3	Differential imset (95) . . . . .	123
1.6.6.4	Differential imset (96) . . . . .	124
1.6.6.5	Differential imset (97) . . . . .	126
1.6.6.6	Differential imset (98) . . . . .	127
1.6.6.7	Differential imset (99) . . . . .	129
1.8	Squared Euclidean length 8 . . . . .	130
1.8.5	Number of nonzero values 5 . . . . .	130
1.8.5.1	Differential imset (100) . . . . .	130
1.8.5.2	Differential imset (101) . . . . .	132
1.8.5.3	Differential imset (102) . . . . .	133
1.8.5.4	Differential imset (103) . . . . .	134
1.8.5.5	Differential imset (104) . . . . .	135
1.8.5.6	Differential imset (105) . . . . .	136
1.8.5.7	Differential imset (106) . . . . .	137
1.8.8	Number of nonzero values 8 . . . . .	138
1.8.8.1	Differential imset (107) . . . . .	138
1.8.8.2	Differential imset (108) . . . . .	139
1.8.8.3	Differential imset (109) . . . . .	140
1.8.8.4	Differential imset (110) . . . . .	141
1.8.8.5	Differential imset (111) . . . . .	142
1.8.8.6	Differential imset (112) . . . . .	143
1.8.8.7	Differential imset (113) . . . . .	144
1.8.8.8	Differential imset (114) . . . . .	145
1.8.8.9	Differential imset (115) . . . . .	146
1.8.8.10	Differential imset (116) . . . . .	147
1.8.8.11	Differential imset (117) . . . . .	148
1.8.8.12	Differential imset (118) . . . . .	149
1.8.8.13	Differential imset (119) . . . . .	150
1.8.8.14	Differential imset (120) . . . . .	151
1.8.8.15	Differential imset (121) . . . . .	152
1.8.8.16	Differential imset (122) . . . . .	153
1.8.8.17	Differential imset (123) . . . . .	154
1.8.8.18	Differential imset (124) . . . . .	155
1.8.8.19	Differential imset (125) . . . . .	156
1.8.8.20	Differential imset (126) . . . . .	157
1.8.8.21	Differential imset (127) . . . . .	159
1.8.8.22	Differential imset (128) . . . . .	160
1.8.8.23	Differential imset (129) . . . . .	161
1.8.8.24	Differential imset (130) . . . . .	162
1.8.8.25	Differential imset (131) . . . . .	163
1.8.8.26	Differential imset (132) . . . . .	164
1.10	Squared Euclidean length 10 . . . . .	166
1.10.7	Number of nonzero values 7 . . . . .	166
1.10.7.1	Differential imset (133) . . . . .	166
1.10.7.2	Differential imset (134) . . . . .	167
1.10.7.3	Differential imset (135) . . . . .	168
1.10.7.4	Differential imset (136) . . . . .	169

1.10.7.5	Differential imset (137)	170
1.10.7.6	Differential imset (138)	171
1.10.7.7	Differential imset (139)	172
1.10.7.8	Differential imset (140)	173
1.10.7.9	Differential imset (141)	174
1.10.7.10	Differential imset (142)	175
1.10.10	Number of nonzero values 10	176
1.10.10.1	Differential imset (143)	176
1.10.10.2	Differential imset (144)	177
1.10.10.3	Differential imset (145)	178
1.10.10.4	Differential imset (146)	179
1.10.10.5	Differential imset (147)	180
1.10.10.6	Differential imset (148)	181
1.10.10.7	Differential imset (149)	182
1.10.10.8	Differential imset (150)	183
1.12	Squared Euclidean length 12	184
1.12.6	Number of nonzero values 6	184
1.12.6.1	Differential imset (151)	184
1.12.6.2	Differential imset (152)	185
1.12.6.3	Differential imset (153)	186
1.12.6.4	Differential imset (154)	187
1.12.6.5	Differential imset (155)	188
1.12.6.6	Differential imset (156)	189
1.12.9	Number of nonzero values 9	190
1.12.9.1	Differential imset (157)	190
1.12.9.2	Differential imset (158)	191
1.12.9.3	Differential imset (159)	192
1.12.9.4	Differential imset (160)	193
1.12.9.5	Differential imset (161)	194
1.12.9.6	Differential imset (162)	195
1.12.9.7	Differential imset (163)	196
1.12.9.8	Differential imset (164)	197
1.12.9.9	Differential imset (165)	198
1.12.9.10	Differential imset (166)	199
1.12.9.11	Differential imset (167)	200
1.12.9.12	Differential imset (168)	201
1.12.9.13	Differential imset (169)	202
1.12.9.14	Differential imset (170)	203
1.12.9.15	Differential imset (171)	204
1.12.9.16	Differential imset (172)	205
1.12.9.17	Differential imset (173)	206
1.12.9.18	Differential imset (174)	207
1.12.9.19	Differential imset (175)	208
1.12.9.20	Differential imset (176)	209
1.12.9.21	Differential imset (177)	210
1.12.9.22	Differential imset (178)	211
1.12.9.23	Differential imset (179)	212
1.12.12	Number of nonzero values 12	213
1.12.12.1	Differential imset (180)	213
1.12.12.2	Differential imset (181)	214
1.12.12.3	Differential imset (182)	215
1.14	Squared Euclidean length 14	216
1.14.8	Number of nonzero values 8	216
1.14.8.1	Differential imset (183)	216
1.14.8.2	Differential imset (184)	217
1.14.8.3	Differential imset (185)	218
1.14.8.4	Differential imset (186)	219
1.14.8.5	Differential imset (187)	220
1.14.11	Number of nonzero values 11	221
1.14.11.1	Differential imset (188)	221
1.14.11.2	Differential imset (189)	222

1.14.11.3	Differential imset (190)	223
1.14.11.4	Differential imset (191)	224
1.14.11.5	Differential imset (192)	225
1.16	Squared Euclidean length 16	226
1.16.7	Number of nonzero values 7	226
1.16.7.1	Differential imset (193)	226
1.16.7.2	Differential imset (194)	227
1.16.7.3	Differential imset (195)	228
1.16.8	Number of nonzero values 8	229
1.16.8.1	Differential imset (196)	229
1.16.8.2	Differential imset (197)	230
1.16.10	Number of nonzero values 10	231
1.16.10.1	Differential imset (198)	231
1.16.10.2	Differential imset (199)	232
1.16.10.3	Differential imset (200)	233
1.16.10.4	Differential imset (201)	234
1.16.10.5	Differential imset (202)	235
1.16.10.6	Differential imset (203)	236
1.16.10.7	Differential imset (204)	237
1.16.10.8	Differential imset (205)	238
1.16.10.9	Differential imset (206)	239
1.16.10.10	Differential imset (207)	240
1.16.10.11	Differential imset (208)	241
1.16.10.12	Differential imset (209)	242
1.16.10.13	Differential imset (210)	243
1.16.10.14	Differential imset (211)	244
1.16.10.15	Differential imset (212)	245
1.16.10.16	Differential imset (213)	246
1.16.10.17	Differential imset (214)	247
1.16.10.18	Differential imset (215)	248
1.16.10.19	Differential imset (216)	249
1.18	Squared Euclidean length 18	250
1.18.9	Number of nonzero values 9	250
1.18.9.1	Differential imset (217)	250
1.18.9.2	Differential imset (218)	251
1.18.9.3	Differential imset (219)	252
1.18.9.4	Differential imset (220)	253
1.18.9.5	Differential imset (221)	254
1.18.9.6	Differential imset (222)	255
1.20	Squared Euclidean length 20	256
1.20.8	Number of nonzero values 8	256
1.20.8.1	Differential imset (223)	256
1.20.8.2	Differential imset (224)	257
1.20.8.3	Differential imset (225)	258
1.20.8.4	Differential imset (226)	259
1.20.9	Number of nonzero values 9	260
1.20.9.1	Differential imset (227)	260
1.20.9.2	Differential imset (228)	261
1.20.9.3	Differential imset (229)	262
1.22	Squared Euclidean length 22	263
1.22.8	Number of nonzero values 8	263
1.22.8.1	Differential imset (230)	263
1.22.8.2	Differential imset (231)	264
1.22.8.3	Differential imset (232)	265

<b>2</b>	<b>Degree difference 2</b>	<b>267</b>
2.4	Squared Euclidean length 4 . . . . .	267
2.4.4	Number of nonzero values 4 . . . . .	267
2.4.4.1	Differential imset (233) . . . . .	267
2.4.4.2	Differential imset (234) . . . . .	269
2.6	Squared Euclidean length 6 . . . . .	270
2.6.6	Number of nonzero values 6 . . . . .	270
2.6.6.1	Differential imset (235) . . . . .	270
2.6.6.2	Differential imset (236) . . . . .	271
2.6.6.3	Differential imset (237) . . . . .	272
2.6.6.4	Differential imset (238) . . . . .	273
2.6.6.5	Differential imset (239) . . . . .	274
2.6.6.6	Differential imset (240) . . . . .	275
2.6.6.7	Differential imset (241) . . . . .	276
2.8	Squared Euclidean length 8 . . . . .	277
2.8.8	Number of nonzero values 8 . . . . .	277
2.8.8.1	Differential imset (242) . . . . .	277
2.8.8.2	Differential imset (243) . . . . .	278
2.8.8.3	Differential imset (244) . . . . .	279
2.8.8.4	Differential imset (245) . . . . .	280
2.8.8.5	Differential imset (246) . . . . .	281
2.8.8.6	Differential imset (247) . . . . .	282
2.8.8.7	Differential imset (248) . . . . .	283
2.8.8.8	Differential imset (249) . . . . .	284
2.8.8.9	Differential imset (250) . . . . .	285
2.8.8.10	Differential imset (251) . . . . .	286
2.10	Squared Euclidean length 10 . . . . .	287
2.10.7	Number of nonzero values 7 . . . . .	287
2.10.7.1	Differential imset (252) . . . . .	287
2.10.7.2	Differential imset (253) . . . . .	288
2.10.7.3	Differential imset (254) . . . . .	289
2.10.7.4	Differential imset (255) . . . . .	290
2.10.7.5	Differential imset (256) . . . . .	291
2.10.7.6	Differential imset (257) . . . . .	292
2.10.7.7	Differential imset (258) . . . . .	293
2.10.7.8	Differential imset (259) . . . . .	294
2.10.7.9	Differential imset (260) . . . . .	295
2.10.7.10	Differential imset (261) . . . . .	296
2.10.7.11	Differential imset (262) . . . . .	297
2.10.10	Number of nonzero values 10 . . . . .	298
2.10.10.1	Differential imset (263) . . . . .	298
2.10.10.2	Differential imset (264) . . . . .	299
2.10.10.3	Differential imset (265) . . . . .	300
2.10.10.4	Differential imset (266) . . . . .	301
2.10.10.5	Differential imset (267) . . . . .	302
2.10.10.6	Differential imset (268) . . . . .	303
2.10.10.7	Differential imset (269) . . . . .	304
2.10.10.8	Differential imset (270) . . . . .	305
2.10.10.9	Differential imset (271) . . . . .	306
2.10.10.10	Differential imset (272) . . . . .	307
2.12	Squared Euclidean length 12 . . . . .	308
2.12.6	Number of nonzero values 6 . . . . .	308
2.12.6.1	Differential imset (273) . . . . .	308
2.12.9	Number of nonzero values 9 . . . . .	309
2.12.9.1	Differential imset (274) . . . . .	309
2.12.9.2	Differential imset (275) . . . . .	310
2.12.9.3	Differential imset (276) . . . . .	311
2.12.9.4	Differential imset (277) . . . . .	312
2.12.9.5	Differential imset (278) . . . . .	313
2.12.9.6	Differential imset (279) . . . . .	314
2.12.9.7	Differential imset (280) . . . . .	315



2.12.12	Number of nonzero values 12	316
2.12.12.1	Differential imset (281)	316
2.14	Squared Euclidean length 14	317
2.14.8	Number of nonzero values 8	317
2.14.8.1	Differential imset (282)	317
2.14.8.2	Differential imset (283)	318
2.14.8.3	Differential imset (284)	319
2.14.8.4	Differential imset (285)	320
2.14.8.5	Differential imset (286)	321
2.14.8.6	Differential imset (287)	322
2.14.8.7	Differential imset (288)	323
2.14.8.8	Differential imset (289)	324
2.14.8.9	Differential imset (290)	325
2.14.8.10	Differential imset (291)	326
2.14.8.11	Differential imset (292)	327
2.14.11	Number of nonzero values 11	328
2.14.11.1	Differential imset (293)	328
2.14.11.2	Differential imset (294)	329
2.16	Squared Euclidean length 16	330
2.16.7	Number of nonzero values 7	330
2.16.7.1	Differential imset (295)	330
2.16.7.2	Differential imset (296)	331
2.16.7.3	Differential imset (297)	332
2.16.10	Number of nonzero values 10	333
2.16.10.1	Differential imset (298)	333
2.16.10.2	Differential imset (299)	334
2.18	Squared Euclidean length 18	335
2.18.7	Number of nonzero values 7	335
2.18.7.1	Differential imset (300)	335
2.18.9	Number of nonzero values 9	336
2.18.9.1	Differential imset (301)	336
2.18.9.2	Differential imset (302)	337
2.18.9.3	Differential imset (303)	338

**3 Degree difference 3 339**

3.4	Squared Euclidean length 4	339
3.4.4	Number of nonzero values 4	339
3.4.4.1	Differential imset (304)	339
3.6	Squared Euclidean length 6	340
3.6.6	Number of nonzero values 6	340
3.6.6.1	Differential imset (305)	340
3.6.6.2	Differential imset (306)	341
3.8	Squared Euclidean length 8	342
3.8.8	Number of nonzero values 8	342
3.8.8.1	Differential imset (307)	342
3.8.8.2	Differential imset (308)	343
3.10	Squared Euclidean length 10	344
3.10.7	Number of nonzero values 7	344
3.10.7.1	Differential imset (309)	344
3.10.7.2	Differential imset (310)	345
3.12	Squared Euclidean length 12	346
3.12.9	Number of nonzero values 9	346
3.12.9.1	Differential imset (311)	346
3.12.9.2	Differential imset (312)	347
3.14	Squared Euclidean length 14	348
3.14.8	Number of nonzero values 8	348
3.14.8.1	Differential imset (313)	348
3.14.11	Number of nonzero values 11	349
3.14.11.1	Differential imset (314)	349
3.16	Squared Euclidean length 16	350
3.16.7	Number of nonzero values 7	350

3.16.7.1	Differential imset (315)	350
3.16.10	Number of nonzero values 10	351
3.16.10.1	Differential imset (316)	351
3.16.10.2	Differential imset (317)	352
3.18	Squared Euclidean length 18	353
3.18.9	Number of nonzero values 9	353
3.18.9.1	Differential imset (318)	353
3.20	Squared Euclidean length 20	354
3.20.8	Number of nonzero values 8	354
3.20.8.1	Differential imset (319)	354

# Introduction

This is a catalogue of types of differential imsets (for standard imsets that are geometric neighbors) over 4 variables. The catalogue is meant as an extension of the paper

M. Studený, J. Vomlel: On open questions in the geometric approach to structural learning Bayesian nets, submitted to International Journal of Approximate Reasoning, special issue WUPES 09.

The motivation and deeper theoretical background is explained in that paper, including rough description of the catalogue in Section 5.2.

Recall that the items in our catalogue are types (= permutation equivalence classes) of differential imsets over 4 variables for those standard imsets that are geometric neighbors. Altogether we have 319 of such types, that is, 319 items in the catalogue.

Each type is described (in the catalogue) by one representative (= a member of the respective permutation equivalence class). It is a differential imset  $w = u - v$ , where  $u, v$  are standard imsets over  $N = \{a, b, c, d\}$  that are geometric neighbors. The items are classified using three criteria/characteristics:

- the *degree difference*, which takes values 0,1,2, and 3,
- the *squared Euclidean length* (of  $w$ ), whose possible values are even numbers between 4 and 22,
- the *number of non-zero values* (in  $w$ ), falling within limits 4 and 12.

Each item in the catalogue is ascribed an identification number, which is an integer between 1 and 319.

The catalogue has a form of a pdf file, which is divided into chapters, sections, subsections and sub-subsections.

- Chapters correspond to the degree difference,
- sections (within each chapter) correspond to the squared Euclidean length,
- subsections (within each section) correspond to the number of non-zero values,
- sub-subsections within each subsections correspond items of the catalogue (= types) that fall within that particular subsection.

The numbering of chapters, sections and subsections is given by the value of the respective characteristic.

One can walk through the catalogue with the help of bookmarks (available by advanced versions of Adobe Reader). The top level of those bookmarks correspond to chapters (= the degree difference). If one clicks on the chapter icon, the Adobe Reader moves to the beginning of the chapter. One can also click on the plus sign + (attached left to the chapter icon) to roll out the icons for sections available within that chapter. (These correspond to the squared Euclidean length.) Again, if one clicks on the section icon the Adobe reader moves to its beginning. Conversely, the icons for sections within a particular chapter can be back hidden if one clicks on the minus sign -, which replaced the former plus sign (attached left to the chapter icon). The same principle holds for revealing (and hiding) subsections within sections and items within subsections.

Thus, the leaves of that virtual tree are items in the catalogue. Each such item contains the following information:

- Hasse diagram (over  $N = \{a, b, c, d\}$ ) of the differential imset  $w$  (that was chosen to represent that particular type)
- record of (the same)  $w$  in terms of basic imsets, that is, in terms of  $\delta_A$  notation,
- one of the shortest possible combinations of elementary imsets (with  $\pm 1$  coefficients) giving  $w$  (see Section 5.1 of the paper for an explanation),

- the list of all pairs of standard imsets  $[u, v]$  that are geometric neighbors and yield  $w$  as their differential imset  $w = u - v$ ,
- the essential graphs for those (pairs of) standard imsets.

# Chapter 0

## Degree difference 0

### 0.4 Squared Euclidean length 4

#### 0.4.4 Number of nonzero values 4

##### 0.4.4.1 Differential imset (1)

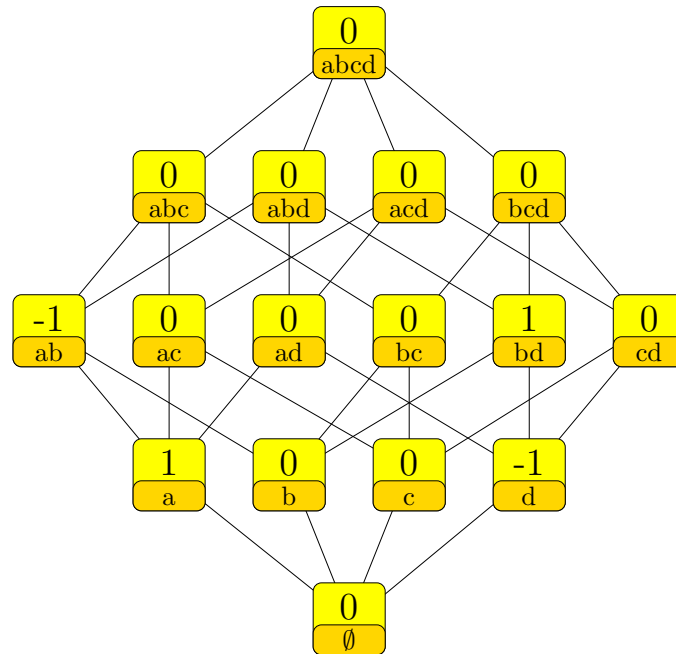

$$\begin{aligned}
 & \delta_{\{a\}} - \delta_{\{d\}} - \delta_{\{a,b\}} + \delta_{\{b,d\}} \\
 &= -u_{\langle a,b|\emptyset \rangle} + u_{\langle b,d|\emptyset \rangle} \\
 &= (+2\delta_{\emptyset} - \delta_{\{b\}} - \delta_{\{c\}} - \delta_{\{d\}} + \delta_{\{b,d\}} - \delta_{\{a,b,d\}} + \delta_{\{a,b,c,d\}}) \\
 &\quad - (+2\delta_{\emptyset} - \delta_{\{a\}} - \delta_{\{b\}} - \delta_{\{c\}} + \delta_{\{a,b\}} - \delta_{\{a,b,d\}} + \delta_{\{a,b,c,d\}}) \\
 &= (\delta_{\emptyset} - \delta_{\{d\}} - \delta_{\{a,b\}} + \delta_{\{a,b,d\}}) \\
 &\quad - (\delta_{\emptyset} - \delta_{\{a\}} - \delta_{\{b,d\}} + \delta_{\{a,b,d\}}) \\
 &= (\delta_{\emptyset} - \delta_{\{b\}} - \delta_{\{d\}} + \delta_{\{a,b\}} + \delta_{\{b,d\}} - \delta_{\{a,b,c\}} - \delta_{\{a,b,d\}} + \delta_{\{a,b,c,d\}}) \\
 &\quad - (\delta_{\emptyset} - \delta_{\{a\}} - \delta_{\{b\}} + 2\delta_{\{a,b\}} - \delta_{\{a,b,c\}} - \delta_{\{a,b,d\}} + \delta_{\{a,b,c,d\}}) \\
 &= (\delta_{\{a\}} - \delta_{\{a,b\}} - \delta_{\{a,d\}} + \delta_{\{a,b,d\}}) \\
 &\quad - (\delta_{\{d\}} - \delta_{\{a,d\}} - \delta_{\{b,d\}} + \delta_{\{a,b,d\}}) \\
 &= (\delta_{\emptyset} - \delta_{\{b\}} - \delta_{\{d\}} + \delta_{\{b,d\}}) \\
 &\quad - (\delta_{\emptyset} - \delta_{\{a\}} - \delta_{\{b\}} + \delta_{\{a,b\}})
 \end{aligned}$$

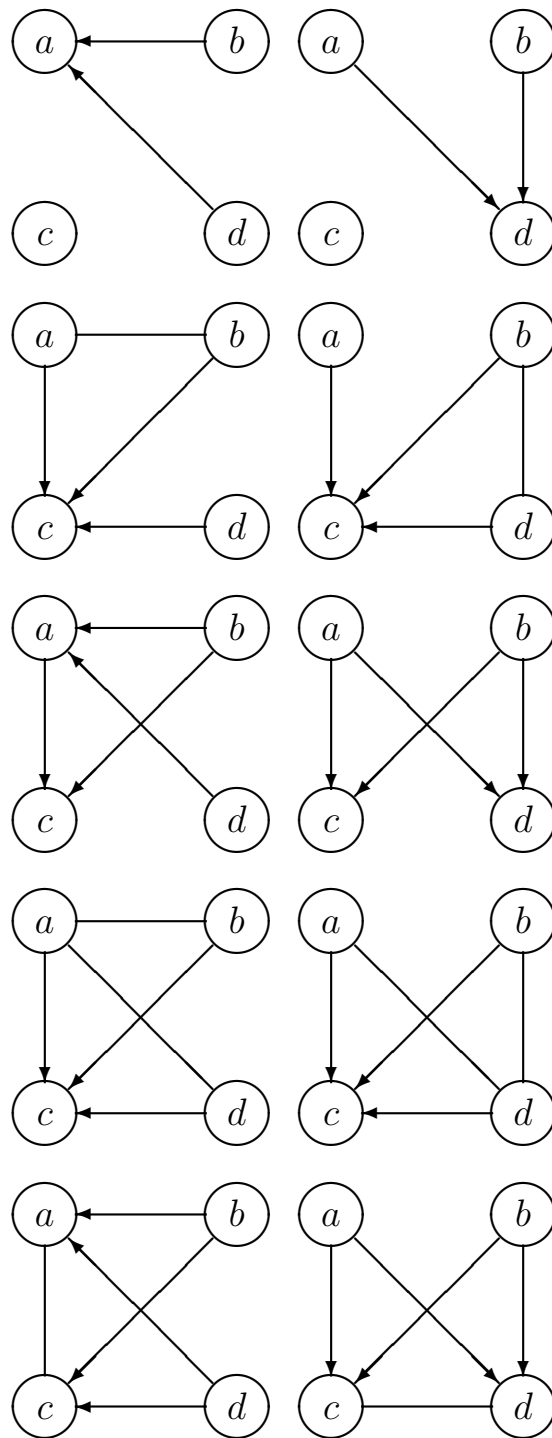

0.4.4.2 Differential inset (2)

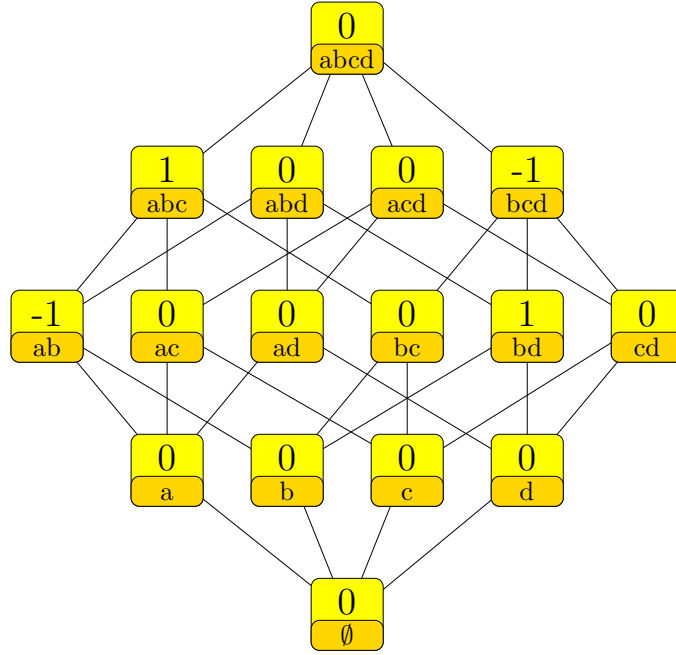

$$\begin{aligned}
 & -\delta_{\{a,b\}} + \delta_{\{b,d\}} + \delta_{\{a,b,c\}} - \delta_{\{b,c,d\}} \\
 &= -u_{\langle c,d|ab \rangle} + u_{\langle a,c|bd \rangle} \\
 &= (+2\delta_\emptyset - \delta_{\{a\}} - \delta_{\{b\}} - \delta_{\{d\}} + \delta_{\{b,d\}} - \delta_{\{b,c,d\}} + \delta_{\{a,b,c,d\}}) \\
 &\quad - (+2\delta_\emptyset - \delta_{\{a\}} - \delta_{\{b\}} - \delta_{\{d\}} + \delta_{\{a,b\}} - \delta_{\{a,b,c\}} + \delta_{\{a,b,c,d\}}) \\
 &= (\delta_\emptyset - \delta_{\{c\}} - \delta_{\{a,b\}} + \delta_{\{b,c\}} - \delta_{\{b,c,d\}} + \delta_{\{a,b,c,d\}}) \\
 &\quad - (\delta_\emptyset - \delta_{\{c\}} + \delta_{\{b,c\}} - \delta_{\{b,d\}} - \delta_{\{a,b,c\}} + \delta_{\{a,b,c,d\}}) \\
 &= (\delta_\emptyset - \delta_{\{b\}} - \delta_{\{a,d\}} + \delta_{\{b,d\}} - \delta_{\{b,c,d\}} + \delta_{\{a,b,c,d\}}) \\
 &\quad - (\delta_\emptyset - \delta_{\{b\}} + \delta_{\{a,b\}} - \delta_{\{a,d\}} - \delta_{\{a,b,c\}} + \delta_{\{a,b,c,d\}}) \\
 &= (\delta_\emptyset - \delta_{\{a\}} - \delta_{\{b\}} + \delta_{\{a,b\}} + \delta_{\{b,d\}} - \delta_{\{a,b,d\}} - \delta_{\{b,c,d\}} + \delta_{\{a,b,c,d\}}) \\
 &\quad - (\delta_\emptyset - \delta_{\{a\}} - \delta_{\{b\}} + 2\delta_{\{a,b\}} - \delta_{\{a,b,c\}} - \delta_{\{a,b,d\}} + \delta_{\{a,b,c,d\}}) \\
 &= (\delta_{\{b\}} - \delta_{\{a,b\}} - \delta_{\{b,c\}} + \delta_{\{a,b,c\}}) \\
 &\quad - (\delta_{\{b\}} - \delta_{\{b,c\}} - \delta_{\{b,d\}} + \delta_{\{b,c,d\}}) \\
 &= (\delta_{\{b,d\}} - \delta_{\{a,b,d\}} - \delta_{\{b,c,d\}} + \delta_{\{a,b,c,d\}}) \\
 &\quad - (\delta_{\{a,b\}} - \delta_{\{a,b,c\}} - \delta_{\{a,b,d\}} + \delta_{\{a,b,c,d\}})
 \end{aligned}$$

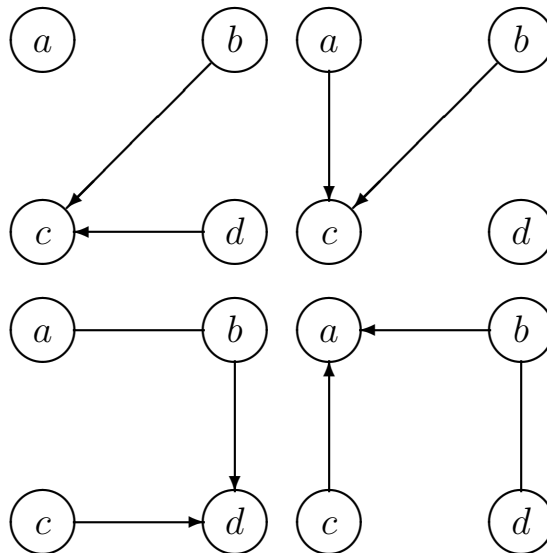

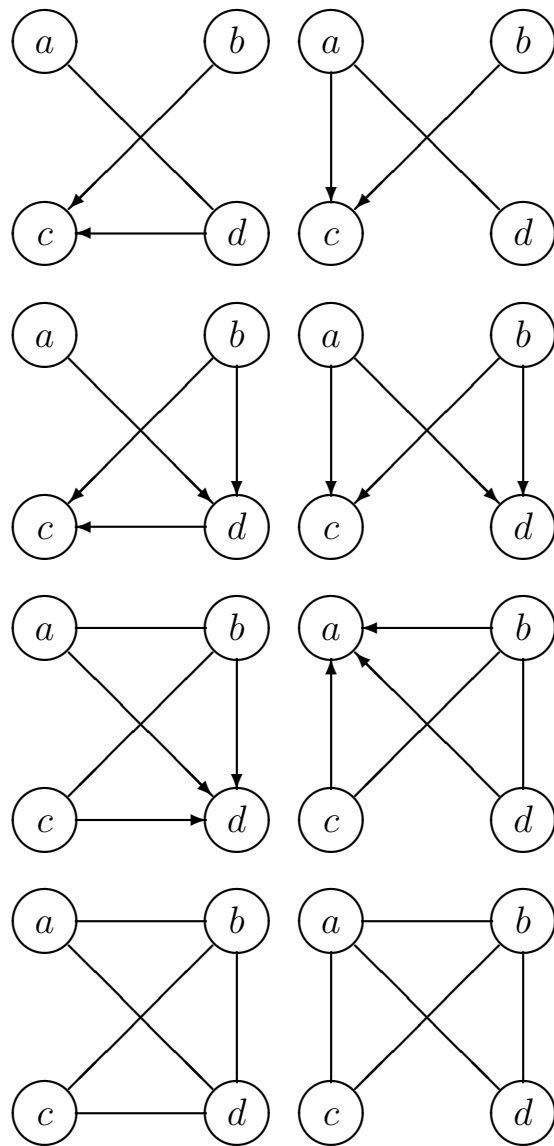



0.4.4.3 Differential inset (3)

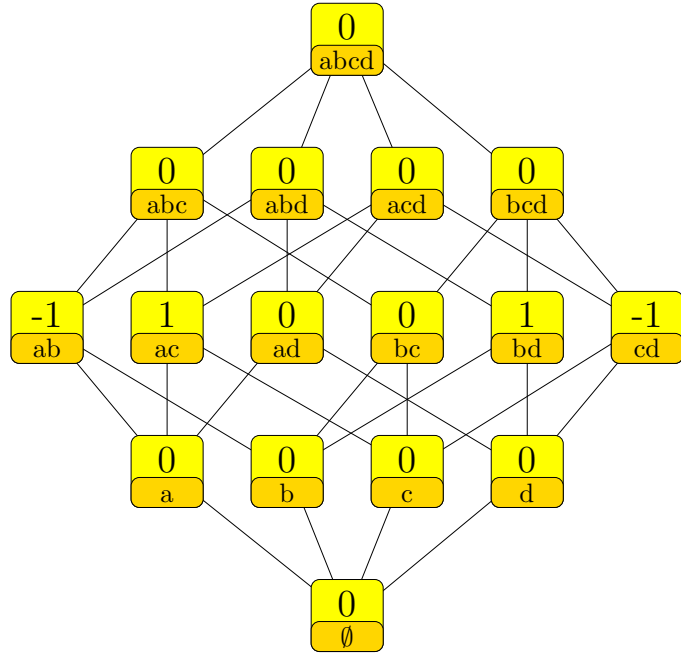

$$\begin{aligned}
 & -\delta_{\{a,b\}} + \delta_{\{a,c\}} + \delta_{\{b,d\}} - \delta_{\{c,d\}} \\
 &= -u_{\langle c,d|ab \rangle} + u_{\langle b,d|ac \rangle} - u_{\langle a,b|d \rangle} + u_{\langle a,c|d \rangle} \\
 &= (\delta_{\{a\}} + \delta_{\{d\}} - \delta_{\{a,b\}} - \delta_{\{a,d\}} - \delta_{\{c,d\}} + \delta_{\{a,b,c,d\}}) \\
 &\quad - (\delta_{\{a\}} + \delta_{\{d\}} - \delta_{\{a,c\}} - \delta_{\{a,d\}} - \delta_{\{b,d\}} + \delta_{\{a,b,c,d\}}) \\
 &= (\delta_{\{a\}} - \delta_{\{a,b\}} - \delta_{\{a,d\}} + \delta_{\{b,d\}} - \delta_{\{b,c,d\}} + \delta_{\{a,b,c,d\}}) \\
 &\quad - (\delta_{\{a\}} - \delta_{\{a,c\}} - \delta_{\{a,d\}} + \delta_{\{c,d\}} - \delta_{\{b,c,d\}} + \delta_{\{a,b,c,d\}}) \\
 &= (\delta_{\{b\}} - \delta_{\{a,b\}} + \delta_{\{a,c\}} - \delta_{\{b,c\}} - \delta_{\{a,c,d\}} + \delta_{\{a,b,c,d\}}) \\
 &\quad - (\delta_{\{b\}} - \delta_{\{b,c\}} - \delta_{\{b,d\}} + \delta_{\{c,d\}} - \delta_{\{a,c,d\}} + \delta_{\{a,b,c,d\}}) \\
 &= (\delta_{\{c\}} - \delta_{\{b,c\}} + \delta_{\{b,d\}} - \delta_{\{c,d\}} - \delta_{\{a,b,d\}} + \delta_{\{a,b,c,d\}}) \\
 &\quad - (\delta_{\{c\}} + \delta_{\{a,b\}} - \delta_{\{a,c\}} - \delta_{\{b,c\}} - \delta_{\{a,b,d\}} + \delta_{\{a,b,c,d\}})
 \end{aligned}$$

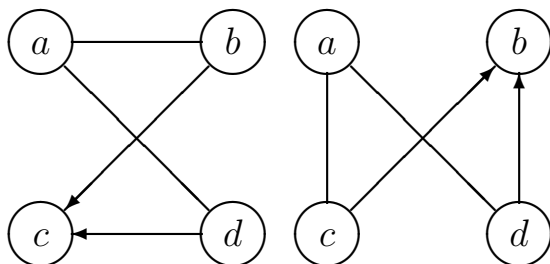
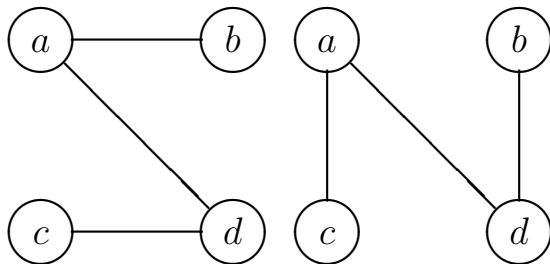

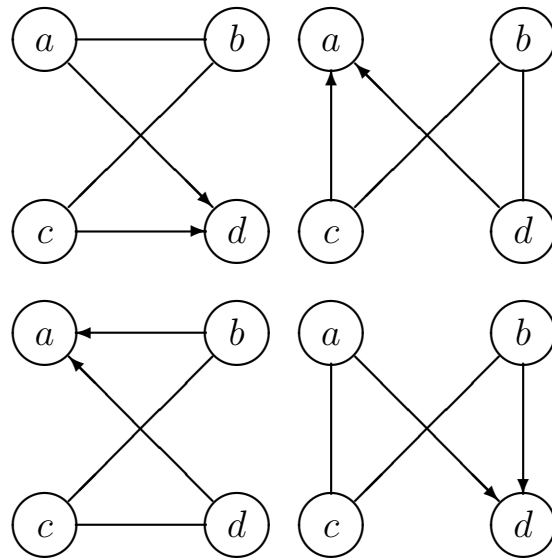

0.4.4.4 Differential inset (4)

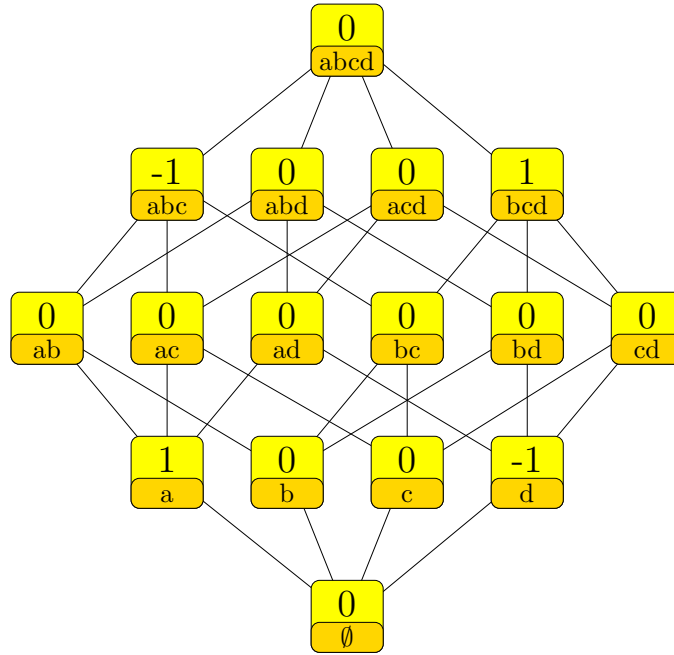

$$\begin{aligned}
 & \delta_{\{a\}} - \delta_{\{d\}} - \delta_{\{a,b,c\}} + \delta_{\{b,c,d\}} \\
 &= -u_{\langle a,b|\emptyset \rangle} + u_{\langle b,d|\emptyset \rangle} + u_{\langle c,d|ab \rangle} - u_{\langle a,c|bd \rangle} \\
 &= (+2\delta_{\emptyset} - \delta_{\{b\}} - \delta_{\{c\}} - \delta_{\{d\}} + \delta_{\{b,c,d\}}) \\
 &\quad - (+2\delta_{\emptyset} - \delta_{\{a\}} - \delta_{\{b\}} - \delta_{\{c\}} + \delta_{\{a,b,c\}}) \\
 &= (\delta_{\emptyset} + \delta_{\{a\}} - \delta_{\{b\}} - \delta_{\{c\}} - \delta_{\{a,d\}} + \delta_{\{b,c\}} - \delta_{\{a,b,c\}} + \delta_{\{a,b,c,d\}}) \\
 &\quad - (\delta_{\emptyset} - \delta_{\{b\}} - \delta_{\{c\}} + \delta_{\{d\}} - \delta_{\{a,d\}} + \delta_{\{b,c\}} - \delta_{\{b,c,d\}} + \delta_{\{a,b,c,d\}}) \\
 &= (\delta_{\{a\}} - \delta_{\{a,d\}} - \delta_{\{a,b,c\}} + \delta_{\{a,b,c,d\}}) \\
 &\quad - (\delta_{\{d\}} - \delta_{\{a,d\}} - \delta_{\{b,c,d\}} + \delta_{\{a,b,c,d\}})
 \end{aligned}$$

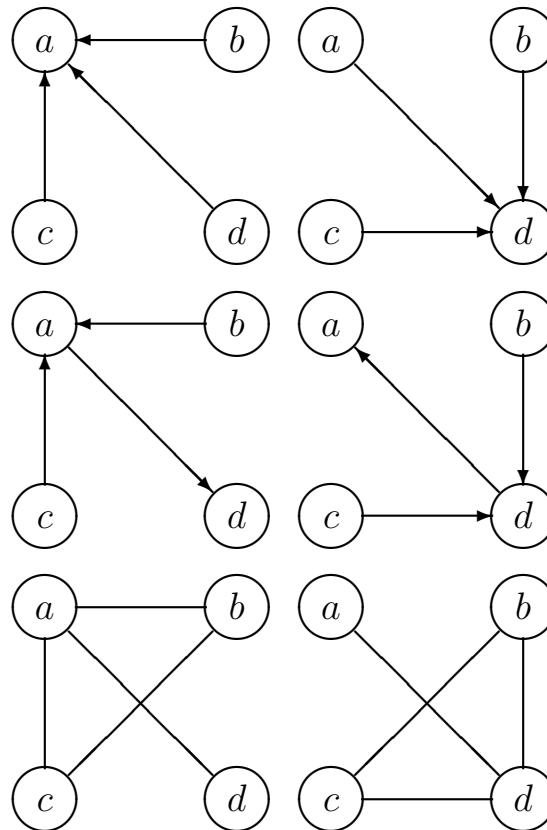

## 0.6 Squared Euclidean length 6

### 0.6.6 Number of nonzero values 6

#### 0.6.6.1 Differential inset (5)

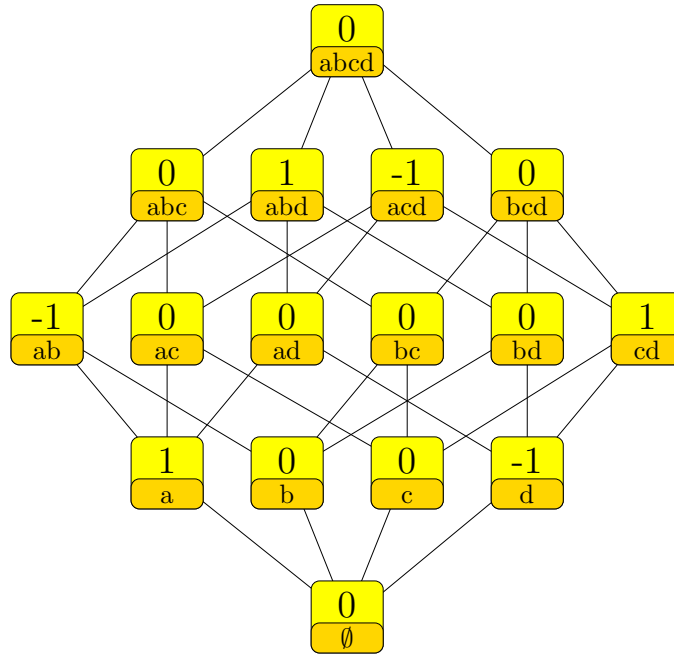

$$\begin{aligned}
 & \delta_{\{a\}} - \delta_{\{d\}} - \delta_{\{a,b\}} + \delta_{\{c,d\}} + \delta_{\{a,b,d\}} - \delta_{\{a,c,d\}} \\
 &= u_{\langle b,d|a \rangle} - u_{\langle a,c|d \rangle} \\
 &= (+2\delta_{\emptyset} - \delta_{\{b\}} - \delta_{\{c\}} - \delta_{\{d\}} + \delta_{\{c,d\}} - \delta_{\{a,c,d\}} + \delta_{\{a,b,c,d\}}) \\
 &\quad - (+2\delta_{\emptyset} - \delta_{\{a\}} - \delta_{\{b\}} - \delta_{\{c\}} + \delta_{\{a,b\}} - \delta_{\{a,b,d\}} + \delta_{\{a,b,c,d\}}) \\
 &= (\delta_{\emptyset} - \delta_{\{b\}} - \delta_{\{d\}} + \delta_{\{b,d\}} + \delta_{\{c,d\}} - \delta_{\{a,c,d\}} - \delta_{\{b,c,d\}} + \delta_{\{a,b,c,d\}}) \\
 &\quad - (\delta_{\emptyset} - \delta_{\{a\}} - \delta_{\{b\}} + \delta_{\{a,b\}} + \delta_{\{b,d\}} - \delta_{\{a,b,d\}} - \delta_{\{b,c,d\}} + \delta_{\{a,b,c,d\}})
 \end{aligned}$$

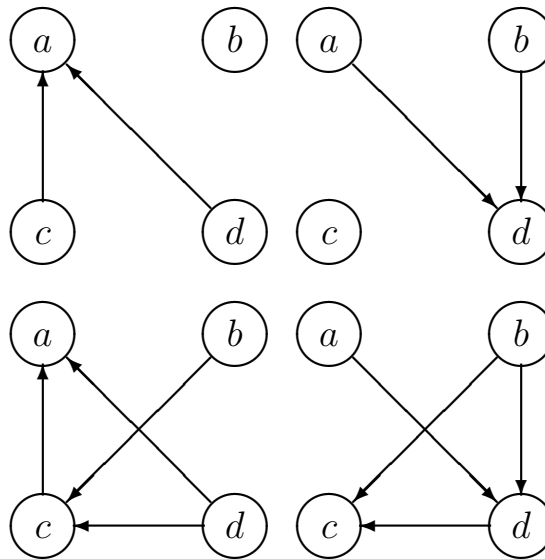

0.6.6.2 Differential inset (6)

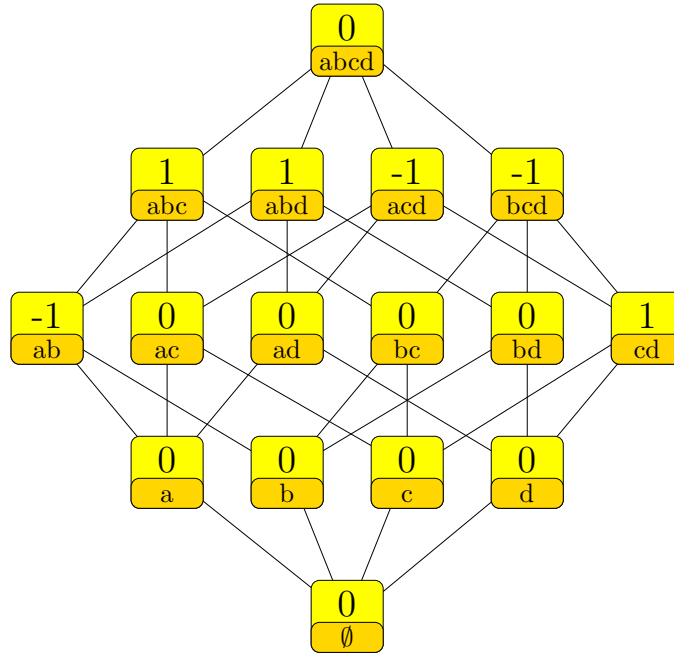

$$\begin{aligned}
 & -\delta_{\{a,b\}} + \delta_{\{c,d\}} + \delta_{\{a,b,c\}} + \delta_{\{a,b,d\}} - \delta_{\{a,c,d\}} - \delta_{\{b,c,d\}} \\
 &= -u_{\langle c,d|ab \rangle} + u_{\langle a,b|cd \rangle} \\
 &= (\delta_\emptyset - \delta_{\{a\}} - \delta_{\{d\}} + \delta_{\{a,d\}} + \delta_{\{c,d\}} - \delta_{\{a,c,d\}} - \delta_{\{b,c,d\}} + \delta_{\{a,b,c,d\}}) \\
 &\quad - (\delta_\emptyset - \delta_{\{a\}} - \delta_{\{d\}} + \delta_{\{a,b\}} + \delta_{\{a,d\}} - \delta_{\{a,b,c\}} - \delta_{\{a,b,d\}} + \delta_{\{a,b,c,d\}}) \\
 &= (\delta_{\{c,d\}} - \delta_{\{a,c,d\}} - \delta_{\{b,c,d\}} + \delta_{\{a,b,c,d\}}) \\
 &\quad - (\delta_{\{a,b\}} - \delta_{\{a,b,c\}} - \delta_{\{a,b,d\}} + \delta_{\{a,b,c,d\}})
 \end{aligned}$$

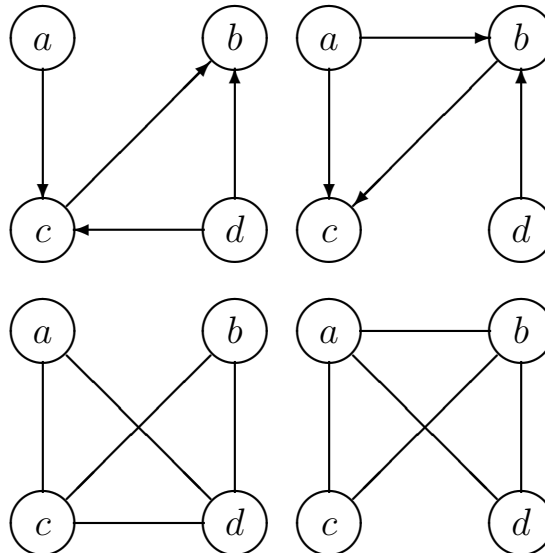

0.6.6.3 Differential inset (7)

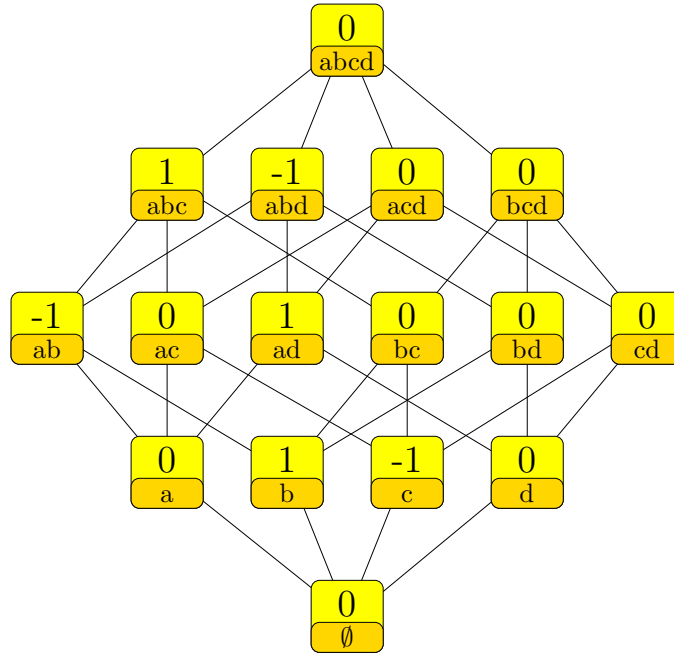

$$\begin{aligned}
 & \delta_{\{b\}} - \delta_{\{c\}} - \delta_{\{a,b\}} + \delta_{\{a,d\}} + \delta_{\{a,b,c\}} - \delta_{\{a,b,d\}} \\
 &= -u_{\langle a,b|\emptyset \rangle} + u_{\langle a,c|\emptyset \rangle} - u_{\langle b,d|ac \rangle} + u_{\langle b,c|ad \rangle} \\
 &= (\delta_{\emptyset} - \delta_{\{a\}} + \delta_{\{a,d\}} - \delta_{\{c,d\}} - \delta_{\{a,b,d\}} + \delta_{\{a,b,c,d\}}) \\
 &\quad - (\delta_{\emptyset} - \delta_{\{a\}} - \delta_{\{b\}} + \delta_{\{c\}} + \delta_{\{a,b\}} - \delta_{\{c,d\}} - \delta_{\{a,b,c\}} + \delta_{\{a,b,c,d\}})
 \end{aligned}$$

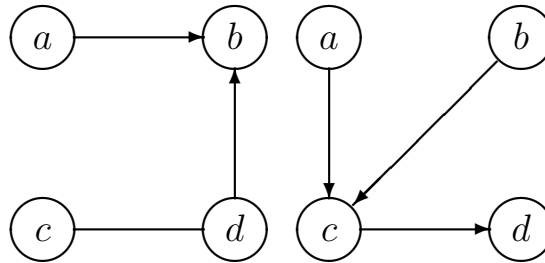

0.6.6.4 Differential inset (8)

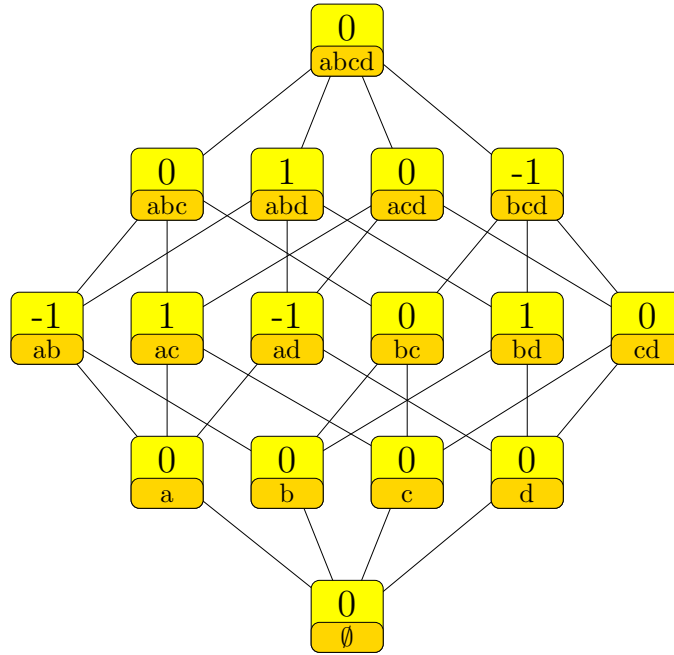

$$\begin{aligned}
 & -\delta_{\{a,b\}} + \delta_{\{a,c\}} - \delta_{\{a,d\}} + \delta_{\{b,d\}} + \delta_{\{a,b,d\}} - \delta_{\{b,c,d\}} \\
 &= -u_{\langle c,d|ab \rangle} + u_{\langle a,c|bd \rangle} - u_{\langle b,c|a \rangle} + u_{\langle b,d|a \rangle} \\
 &= (\delta_{\emptyset} - \delta_{\{b\}} - \delta_{\{a,d\}} + \delta_{\{b,d\}} - \delta_{\{b,c,d\}} + \delta_{\{a,b,c,d\}}) \\
 &\quad - (\delta_{\emptyset} - \delta_{\{b\}} + \delta_{\{a,b\}} - \delta_{\{a,c\}} - \delta_{\{a,b,d\}} + \delta_{\{a,b,c,d\}})
 \end{aligned}$$

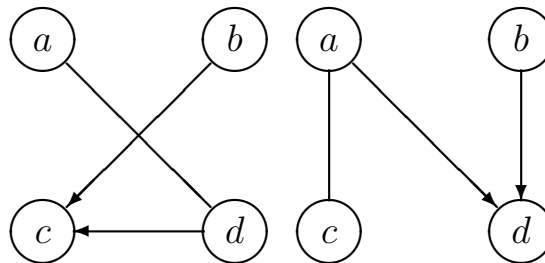

0.6.6.5 Differential imset (9)

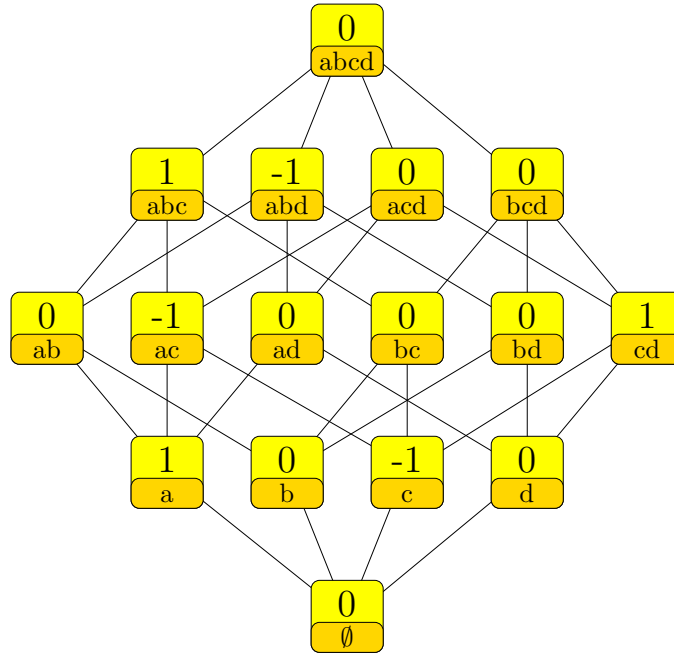

$$\begin{aligned}
 & \delta_{\{a\}} - \delta_{\{c\}} - \delta_{\{a,c\}} + \delta_{\{c,d\}} + \delta_{\{a,b,c\}} - \delta_{\{a,b,d\}} \\
 &= u_{\langle c,d|ab \rangle} - u_{\langle b,d|ac \rangle} + u_{\langle b,c|a \rangle} - u_{\langle a,d|c \rangle} \\
 &= (\delta_{\emptyset} - \delta_{\{b\}} + \delta_{\{a,b\}} - \delta_{\{a,c\}} - \delta_{\{a,b,d\}} + \delta_{\{a,b,c,d\}}) \\
 &\quad - (\delta_{\emptyset} - \delta_{\{a\}} - \delta_{\{b\}} + \delta_{\{c\}} + \delta_{\{a,b\}} - \delta_{\{c,d\}} - \delta_{\{a,b,c\}} + \delta_{\{a,b,c,d\}}) \\
 &= (\delta_{\emptyset} - \delta_{\{c\}} - \delta_{\{d\}} + \delta_{\{a,d\}} + \delta_{\{c,d\}} - \delta_{\{a,b,d\}} - \delta_{\{a,c,d\}} + \delta_{\{a,b,c,d\}}) \\
 &\quad - (\delta_{\emptyset} - \delta_{\{a\}} - \delta_{\{d\}} + \delta_{\{a,c\}} + \delta_{\{a,d\}} - \delta_{\{a,b,c\}} - \delta_{\{a,c,d\}} + \delta_{\{a,b,c,d\}})
 \end{aligned}$$

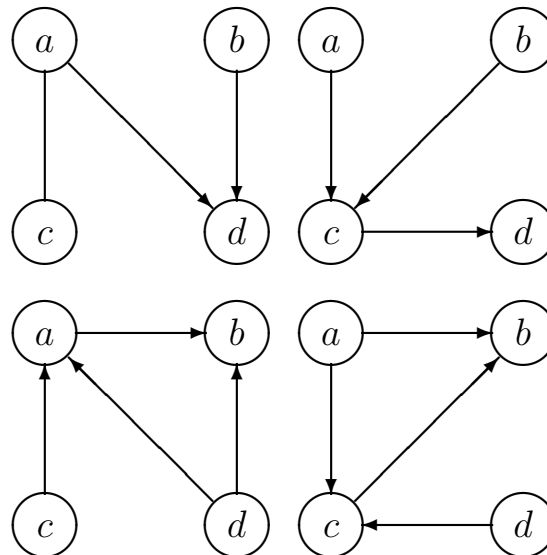



0.6.6.6 Differential inset (10)

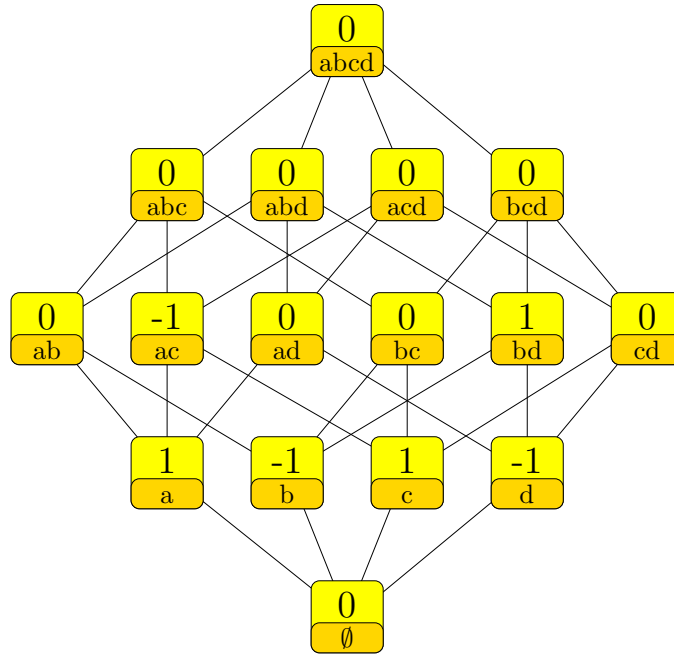

$$\begin{aligned}
 & \delta_{\{a\}} - \delta_{\{b\}} + \delta_{\{c\}} - \delta_{\{d\}} - \delta_{\{a,c\}} + \delta_{\{b,d\}} \\
 &= -u_{\langle a,c|\emptyset \rangle} + u_{\langle b,d|\emptyset \rangle} \\
 &= (\delta_{\emptyset} + \delta_{\{a\}} - \delta_{\{b\}} - \delta_{\{a,c\}} - \delta_{\{a,d\}} + \delta_{\{a,b,c,d\}}) \\
 &\quad - (\delta_{\emptyset} - \delta_{\{c\}} + \delta_{\{d\}} - \delta_{\{a,d\}} - \delta_{\{b,d\}} + \delta_{\{a,b,c,d\}}) \\
 &= (\delta_{\{a\}} + \delta_{\{c\}} - \delta_{\{a,c\}} - \delta_{\{a,d\}} - \delta_{\{b,c\}} + \delta_{\{a,b,c,d\}}) \\
 &\quad - (\delta_{\{b\}} + \delta_{\{d\}} - \delta_{\{a,d\}} - \delta_{\{b,c\}} - \delta_{\{b,d\}} + \delta_{\{a,b,c,d\}}) \\
 &= (\delta_{\emptyset} - \delta_{\{d\}} - \delta_{\{a,b,c\}} + \delta_{\{a,b,c,d\}}) \\
 &\quad - (\delta_{\emptyset} - \delta_{\{a\}} + \delta_{\{b\}} - \delta_{\{c\}} + \delta_{\{a,c\}} - \delta_{\{b,d\}} - \delta_{\{a,b,c\}} + \delta_{\{a,b,c,d\}}) \\
 &= (\delta_{\emptyset} - \delta_{\{b\}} - \delta_{\{a,c,d\}} + \delta_{\{a,b,c,d\}}) \\
 &\quad - (\delta_{\emptyset} - \delta_{\{a\}} - \delta_{\{c\}} + \delta_{\{d\}} + \delta_{\{a,c\}} - \delta_{\{b,d\}} - \delta_{\{a,c,d\}} + \delta_{\{a,b,c,d\}}) \\
 &= (\delta_{\emptyset} - \delta_{\{b\}} - \delta_{\{d\}} + \delta_{\{b,d\}} + \delta_{\{c,d\}} - \delta_{\{a,c,d\}} - \delta_{\{b,c,d\}} + \delta_{\{a,b,c,d\}}) \\
 &\quad - (\delta_{\emptyset} - \delta_{\{a\}} - \delta_{\{c\}} + \delta_{\{a,c\}} + \delta_{\{c,d\}} - \delta_{\{a,c,d\}} - \delta_{\{b,c,d\}} + \delta_{\{a,b,c,d\}}) \\
 &= (\delta_{\emptyset} - \delta_{\{b\}} - \delta_{\{d\}} + \delta_{\{b,c\}} + \delta_{\{b,d\}} - \delta_{\{a,b,c\}} - \delta_{\{b,c,d\}} + \delta_{\{a,b,c,d\}}) \\
 &\quad - (\delta_{\emptyset} - \delta_{\{a\}} - \delta_{\{c\}} + \delta_{\{a,c\}} + \delta_{\{b,c\}} - \delta_{\{a,b,c\}} - \delta_{\{b,c,d\}} + \delta_{\{a,b,c,d\}}) \\
 &= (\delta_{\emptyset} - \delta_{\{b\}} - \delta_{\{d\}} + \delta_{\{b,d\}}) \\
 &\quad - (\delta_{\emptyset} - \delta_{\{a\}} - \delta_{\{c\}} + \delta_{\{a,c\}})
 \end{aligned}$$

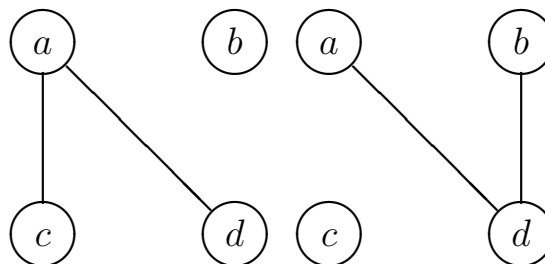

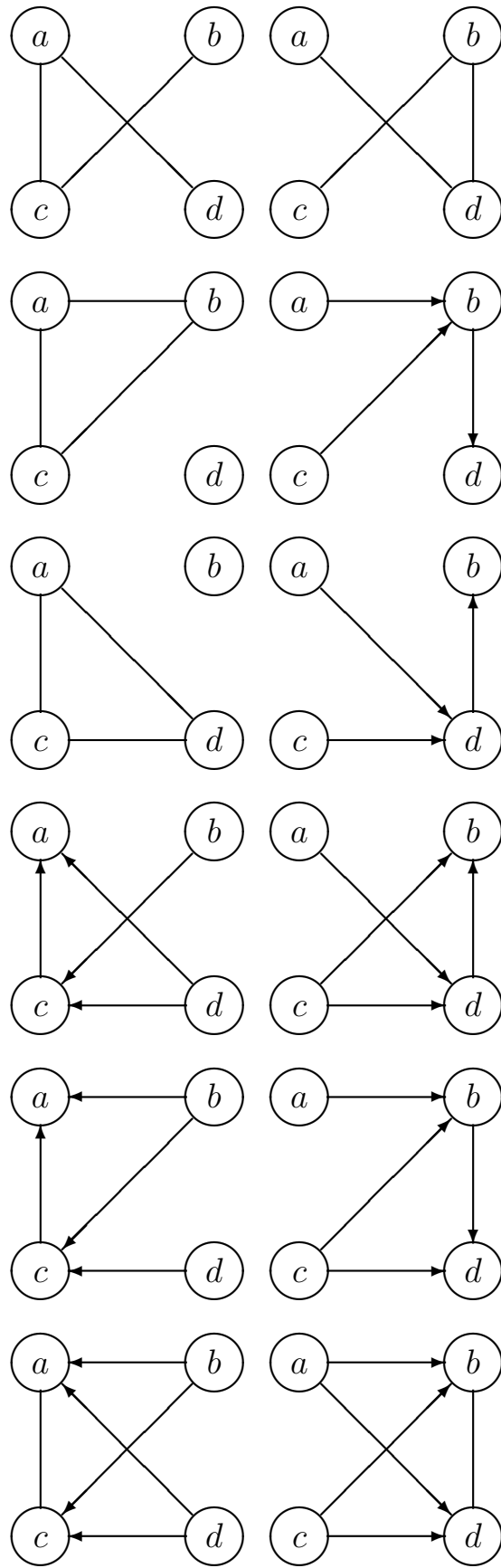

0.6.6.7 Differential inset (11)

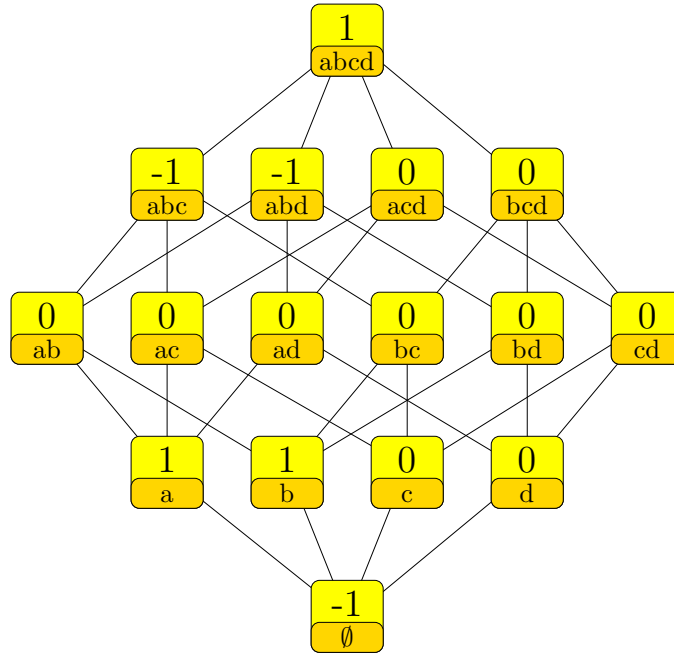

$$\begin{aligned}
 & -\delta_\emptyset + \delta_{\{a\}} + \delta_{\{b\}} - \delta_{\{a,b,c\}} - \delta_{\{a,b,d\}} + \delta_{\{a,b,c,d\}} \\
 &= -u_{\langle a,b|\emptyset \rangle} + u_{\langle c,d|ab \rangle} \\
 &= (\delta_{\{b\}} - \delta_{\{b,d\}} - \delta_{\{a,b,c\}} + \delta_{\{a,b,c,d\}}) \\
 &\quad - (\delta_\emptyset - \delta_{\{a\}} - \delta_{\{b,d\}} + \delta_{\{a,b,d\}})
 \end{aligned}$$

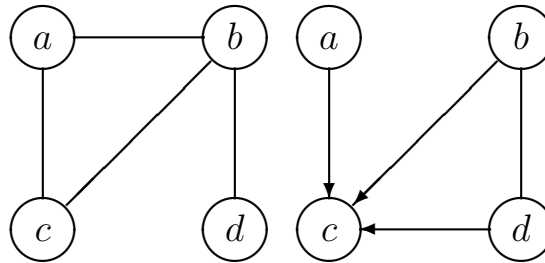

0.6.6.8 Differential imset (12)

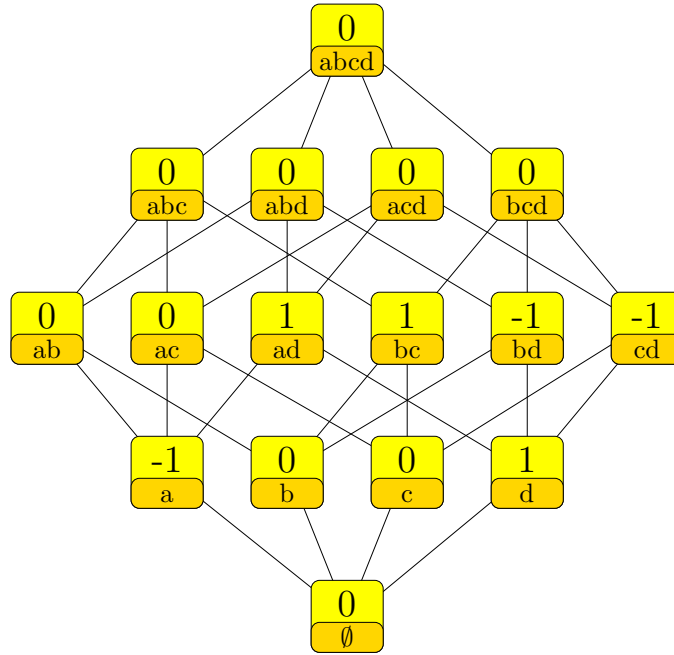

$$\begin{aligned}
 & -\delta_{\{a\}} + \delta_{\{d\}} + \delta_{\{a,d\}} + \delta_{\{b,c\}} - \delta_{\{b,d\}} - \delta_{\{c,d\}} \\
 &= -u_{\langle c,d|ab \rangle} + u_{\langle a,d|bc \rangle} - u_{\langle b,d|a \rangle} + u_{\langle b,c|d \rangle} \\
 &= (\delta_{\emptyset} - \delta_{\{a\}} + \delta_{\{d\}} - \delta_{\{b,d\}} - \delta_{\{c,d\}} + \delta_{\{a,b,c,d\}}) \\
 &\quad - (\delta_{\emptyset} - \delta_{\{a,d\}} - \delta_{\{b,c\}} + \delta_{\{a,b,c,d\}})
 \end{aligned}$$

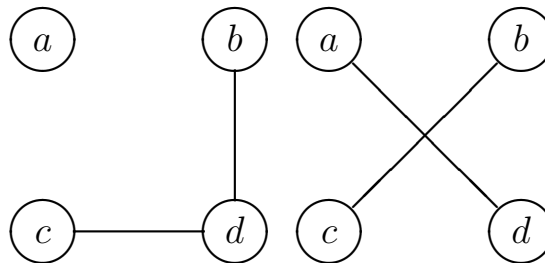

## 0.8 Squared Euclidean length 8

### 0.8.8 Number of nonzero values 8

#### 0.8.8.1 Differential imset (13)

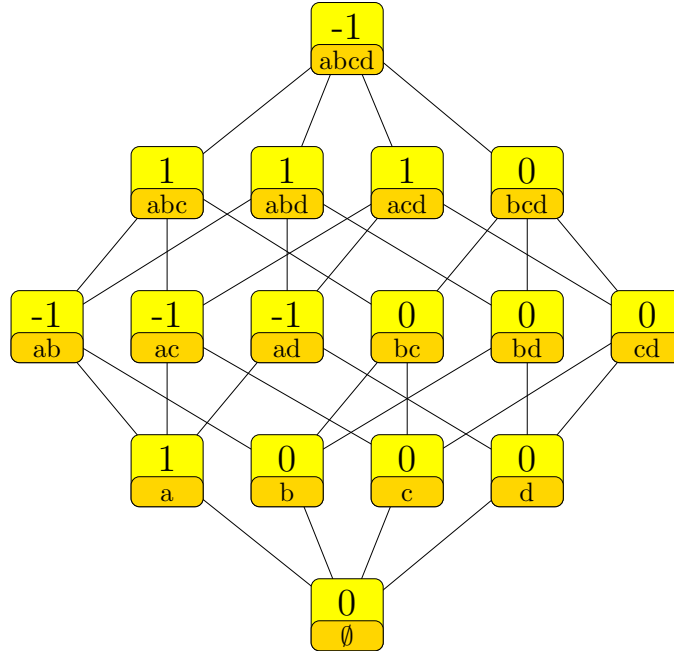

$$\begin{aligned}
 & \delta_{\{a\}} - \delta_{\{a,b\}} - \delta_{\{a,c\}} - \delta_{\{a,d\}} + \delta_{\{a,b,c\}} + \delta_{\{a,b,d\}} + \delta_{\{a,c,d\}} - \delta_{\{a,b,c,d\}} \\
 &= -u_{\langle b,d|ac \rangle} + u_{\langle b,d|a \rangle} \\
 &= (\delta_{\emptyset} - \delta_{\{d\}} - \delta_{\{a,b\}} + \delta_{\{a,b,d\}}) \\
 &\quad - (\delta_{\emptyset} - \delta_{\{a\}} - \delta_{\{d\}} + \delta_{\{a,c\}} + \delta_{\{a,d\}} - \delta_{\{a,b,c\}} - \delta_{\{a,c,d\}} + \delta_{\{a,b,c,d\}}) \\
 &= (\delta_{\emptyset} - \delta_{\{d\}} - \delta_{\{a,c\}} + \delta_{\{a,c,d\}}) \\
 &\quad - (\delta_{\emptyset} - \delta_{\{a\}} - \delta_{\{d\}} + \delta_{\{a,b\}} + \delta_{\{a,d\}} - \delta_{\{a,b,c\}} - \delta_{\{a,b,d\}} + \delta_{\{a,b,c,d\}}) \\
 &= (\delta_{\emptyset} - \delta_{\{b\}} - \delta_{\{a,c\}} + \delta_{\{a,b,c\}}) \\
 &\quad - (\delta_{\emptyset} - \delta_{\{a\}} - \delta_{\{b\}} + \delta_{\{a,b\}} + \delta_{\{a,d\}} - \delta_{\{a,b,d\}} - \delta_{\{a,c,d\}} + \delta_{\{a,b,c,d\}}) \\
 &= (\delta_{\emptyset} - \delta_{\{c\}} - \delta_{\{a,d\}} + \delta_{\{a,c,d\}}) \\
 &\quad - (\delta_{\emptyset} - \delta_{\{a\}} - \delta_{\{c\}} + \delta_{\{a,b\}} + \delta_{\{a,c\}} - \delta_{\{a,b,c\}} - \delta_{\{a,b,d\}} + \delta_{\{a,b,c,d\}}) \\
 &= (\delta_{\{a\}} - \delta_{\{a,b\}} - \delta_{\{a,c\}} + \delta_{\{a,b,c\}}) \\
 &\quad - (\delta_{\{a,d\}} - \delta_{\{a,b,d\}} - \delta_{\{a,c,d\}} + \delta_{\{a,b,c,d\}}) \\
 &= (\delta_{\{a\}} - \delta_{\{a,b\}} - \delta_{\{a,d\}} + \delta_{\{a,b,d\}}) \\
 &\quad - (\delta_{\{a,c\}} - \delta_{\{a,b,c\}} - \delta_{\{a,c,d\}} + \delta_{\{a,b,c,d\}})
 \end{aligned}$$

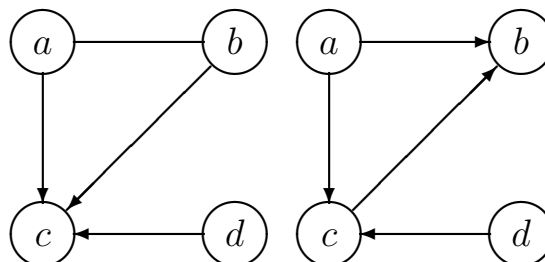

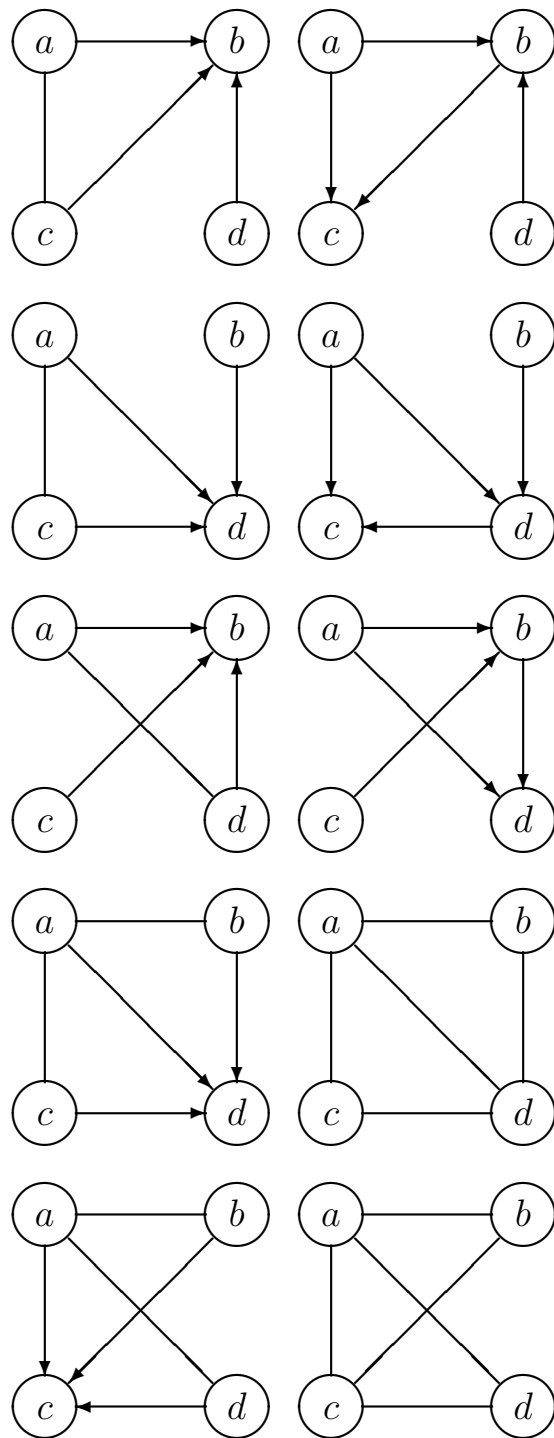

0.8.8.2 Differential inset (14)

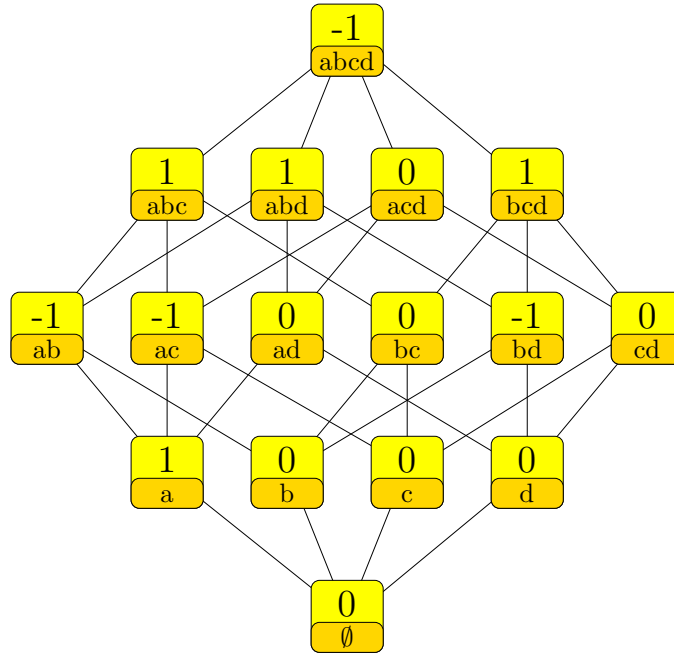

$$\begin{aligned}
 & \delta_{\{a\}} - \delta_{\{a,b\}} - \delta_{\{a,c\}} - \delta_{\{b,d\}} + \delta_{\{a,b,c\}} + \delta_{\{a,b,d\}} + \delta_{\{b,c,d\}} - \delta_{\{a,b,c,d\}} \\
 &= -u_{\langle a,c|bd \rangle} + u_{\langle b,c|a \rangle} \\
 &= (\delta_{\emptyset} - \delta_{\{c\}} - \delta_{\{b,d\}} + \delta_{\{b,c,d\}}) \\
 &\quad - (\delta_{\emptyset} - \delta_{\{a\}} - \delta_{\{c\}} + \delta_{\{a,b\}} + \delta_{\{a,c\}} - \delta_{\{a,b,c\}} - \delta_{\{a,b,d\}} + \delta_{\{a,b,c,d\}}) \\
 &= (\delta_{\{a\}} - \delta_{\{a,b\}} - \delta_{\{a,c\}} + \delta_{\{a,b,c\}}) \\
 &\quad - (\delta_{\{b,d\}} - \delta_{\{a,b,d\}} - \delta_{\{b,c,d\}} + \delta_{\{a,b,c,d\}})
 \end{aligned}$$

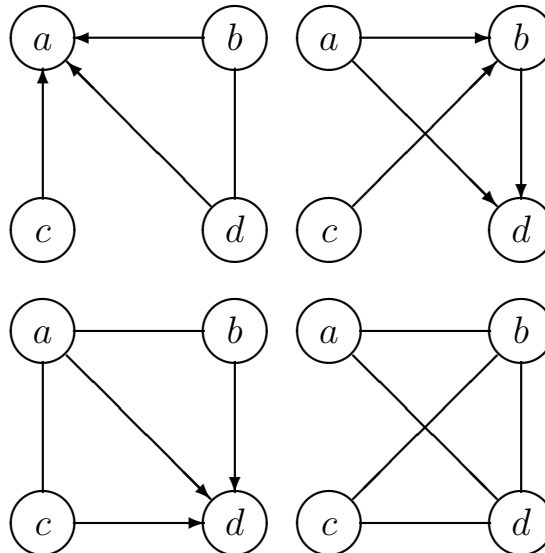

0.8.8.3 Differential inset (15)

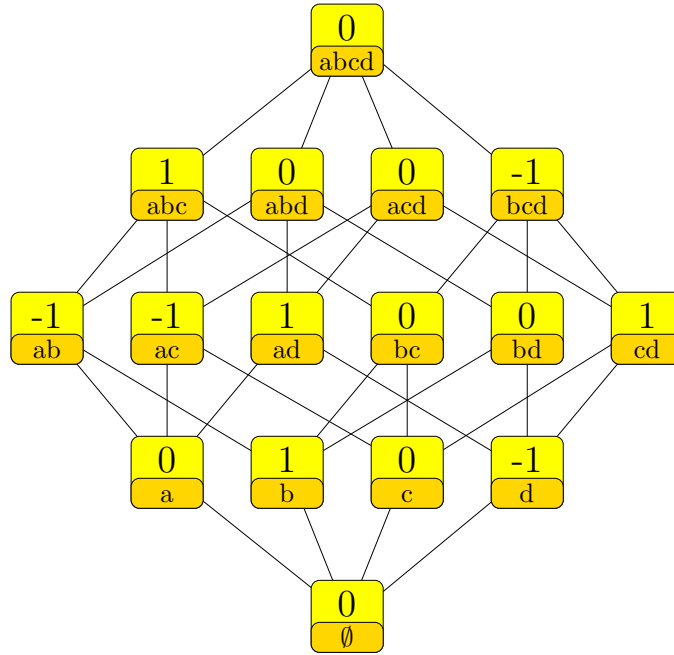

$$\begin{aligned}
 & \delta_{\{b\}} - \delta_{\{d\}} - \delta_{\{a,b\}} - \delta_{\{a,c\}} + \delta_{\{a,d\}} + \delta_{\{c,d\}} + \delta_{\{a,b,c\}} - \delta_{\{b,c,d\}} \\
 &= -u_{\langle a,b|\emptyset \rangle} + u_{\langle a,d|\emptyset \rangle} - u_{\langle b,d|ac \rangle} + u_{\langle a,b|cd \rangle} \\
 &= (\delta_{\emptyset} - \delta_{\{d\}} - \delta_{\{a,c\}} + \delta_{\{c,d\}} - \delta_{\{b,c,d\}} + \delta_{\{a,b,c,d\}}) \\
 &\quad - (\delta_{\emptyset} - \delta_{\{b\}} + \delta_{\{a,b\}} - \delta_{\{a,d\}} - \delta_{\{a,b,c\}} + \delta_{\{a,b,c,d\}}) \\
 &= (\delta_{\emptyset} - \delta_{\{a\}} - \delta_{\{d\}} + \delta_{\{a,d\}} + \delta_{\{c,d\}} - \delta_{\{a,c,d\}} - \delta_{\{b,c,d\}} + \delta_{\{a,b,c,d\}}) \\
 &\quad - (\delta_{\emptyset} - \delta_{\{a\}} - \delta_{\{b\}} + \delta_{\{a,b\}} + \delta_{\{a,c\}} - \delta_{\{a,b,c\}} - \delta_{\{a,c,d\}} + \delta_{\{a,b,c,d\}})
 \end{aligned}$$

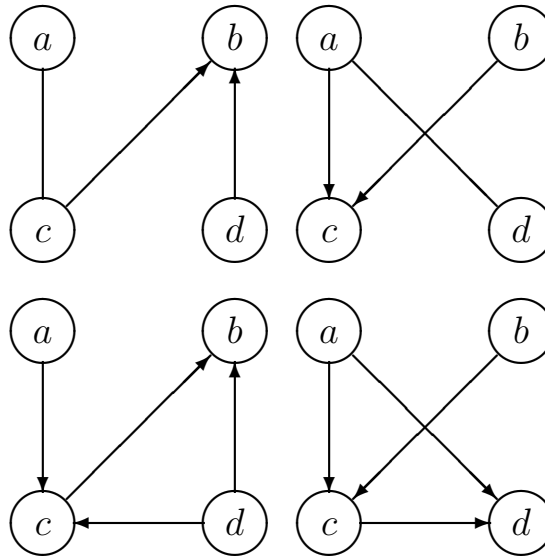



0.8.8.4 Differential inset (16)

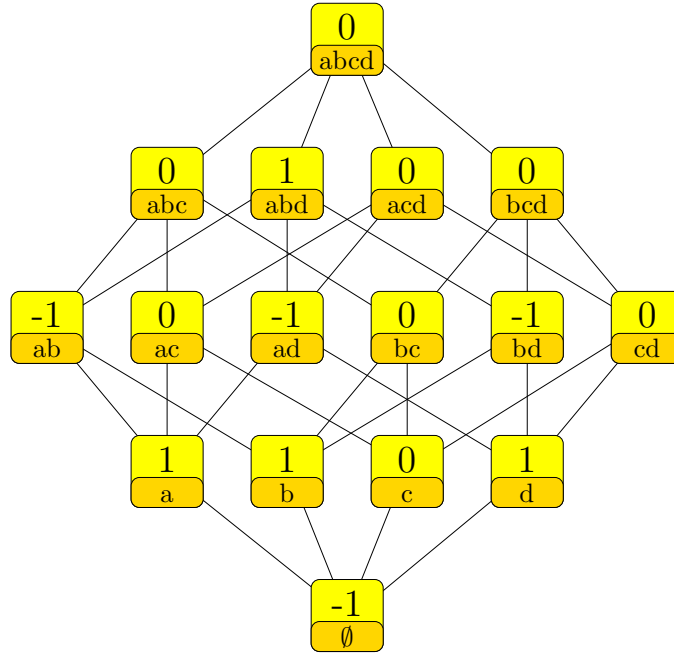

$$\begin{aligned}
 & -\delta_{\emptyset} + \delta_{\{a\}} + \delta_{\{b\}} + \delta_{\{d\}} - \delta_{\{a,b\}} - \delta_{\{a,d\}} - \delta_{\{b,d\}} + \delta_{\{a,b,d\}} \\
 &= -u_{\langle b,d|\emptyset \rangle} + u_{\langle b,d|a \rangle} \\
 &= (\delta_{\{a\}} + \delta_{\{b\}} - \delta_{\{a,b\}} - \delta_{\{a,d\}} - \delta_{\{b,c\}} + \delta_{\{a,b,c,d\}}) \\
 &\quad - (\delta_{\emptyset} - \delta_{\{d\}} - \delta_{\{b,c\}} + \delta_{\{b,d\}} - \delta_{\{a,b,d\}} + \delta_{\{a,b,c,d\}}) \\
 &= (\delta_{\{b\}} - \delta_{\{a,b\}} - \delta_{\{b,c,d\}} + \delta_{\{a,b,c,d\}}) \\
 &\quad - (\delta_{\emptyset} - \delta_{\{a\}} - \delta_{\{d\}} + \delta_{\{a,d\}} + \delta_{\{b,d\}} - \delta_{\{a,b,d\}} - \delta_{\{b,c,d\}} + \delta_{\{a,b,c,d\}}) \\
 &= (\delta_{\{b\}} - \delta_{\{b,d\}} - \delta_{\{a,b,c\}} + \delta_{\{a,b,c,d\}}) \\
 &\quad - (\delta_{\emptyset} - \delta_{\{a\}} - \delta_{\{d\}} + \delta_{\{a,b\}} + \delta_{\{a,d\}} - \delta_{\{a,b,c\}} - \delta_{\{a,b,d\}} + \delta_{\{a,b,c,d\}}) \\
 &= (\delta_{\{d\}} - \delta_{\{a,d\}} - \delta_{\{b,d\}} + \delta_{\{a,b,d\}}) \\
 &\quad - (\delta_{\emptyset} - \delta_{\{a\}} - \delta_{\{b\}} + \delta_{\{a,b\}})
 \end{aligned}$$

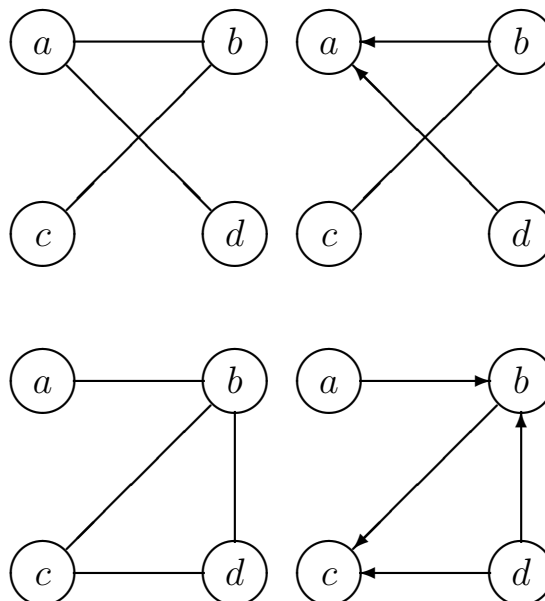

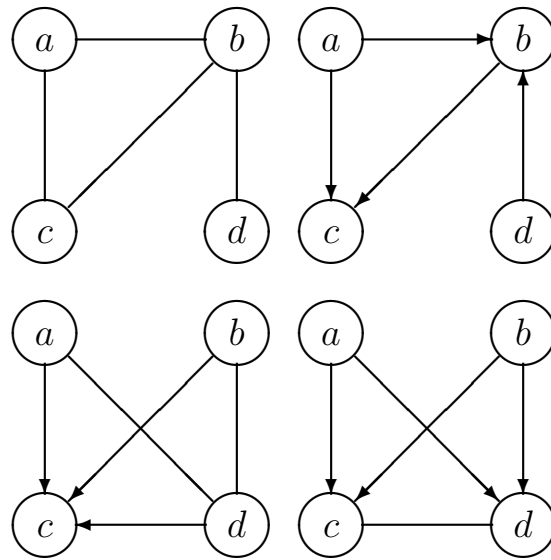

0.8.8.5 Differential inset (17)

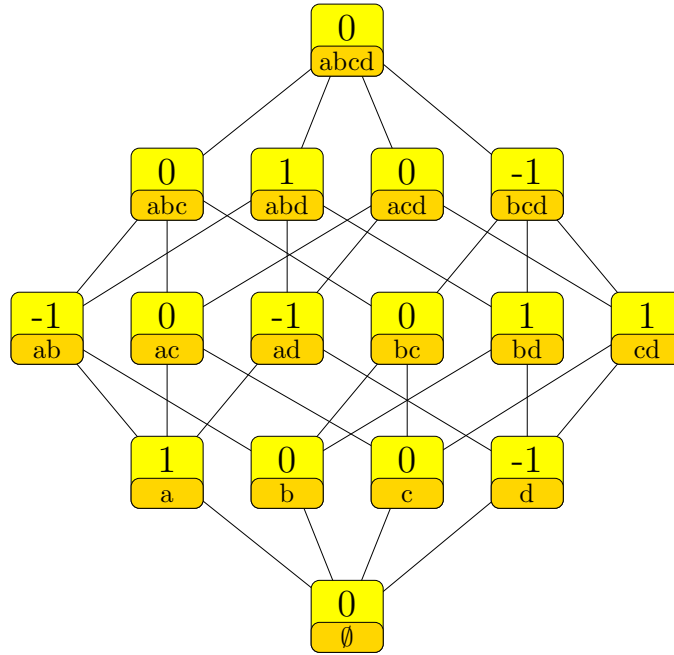

$$\begin{aligned}
 & \delta_{\{a\}} - \delta_{\{d\}} - \delta_{\{a,b\}} - \delta_{\{a,d\}} + \delta_{\{b,d\}} + \delta_{\{c,d\}} + \delta_{\{a,b,d\}} - \delta_{\{b,c,d\}} \\
 &= u_{(b,d|a)} - u_{(b,c|d)} \\
 &= (\delta_{\emptyset} - \delta_{\{d\}} - \delta_{\{a,b\}} + \delta_{\{b,d\}} - \delta_{\{b,c,d\}} + \delta_{\{a,b,c,d\}}) \\
 &\quad - (\delta_{\emptyset} - \delta_{\{a\}} + \delta_{\{a,d\}} - \delta_{\{c,d\}} - \delta_{\{a,b,d\}} + \delta_{\{a,b,c,d\}}) \\
 &= (\delta_{\emptyset} - \delta_{\{b\}} - \delta_{\{d\}} + \delta_{\{b,d\}} + \delta_{\{c,d\}} - \delta_{\{a,c,d\}} - \delta_{\{b,c,d\}} + \delta_{\{a,b,c,d\}}) \\
 &\quad - (\delta_{\emptyset} - \delta_{\{a\}} - \delta_{\{b\}} + \delta_{\{a,b\}} + \delta_{\{a,d\}} - \delta_{\{a,b,d\}} - \delta_{\{a,c,d\}} + \delta_{\{a,b,c,d\}}) \\
 &= (\delta_{\{a\}} - \delta_{\{a,b\}} - \delta_{\{a,d\}} + \delta_{\{a,b,d\}}) \\
 &\quad - (\delta_{\{d\}} - \delta_{\{b,d\}} - \delta_{\{c,d\}} + \delta_{\{b,c,d\}})
 \end{aligned}$$

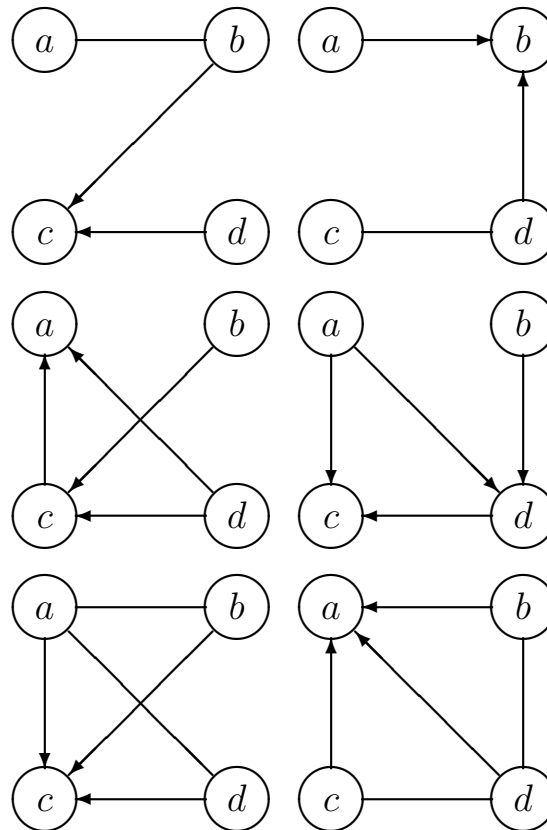

0.8.8.6 Differential inset (18)

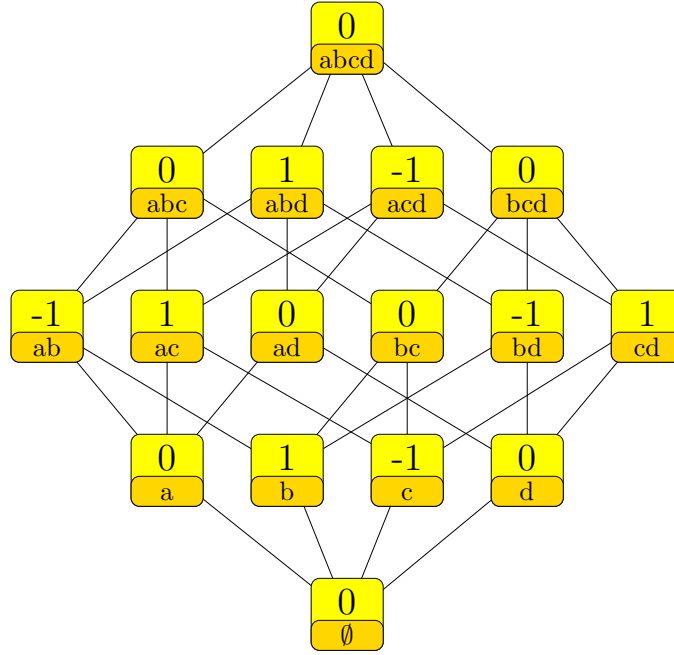

$$\begin{aligned}
 & \delta_{\{b\}} - \delta_{\{c\}} - \delta_{\{a,b\}} + \delta_{\{a,c\}} - \delta_{\{b,d\}} + \delta_{\{c,d\}} + \delta_{\{a,b,d\}} - \delta_{\{a,c,d\}} \\
 &= u_{\langle a,d|b \rangle} - u_{\langle a,d|c \rangle} \\
 &= (\delta_{\emptyset} - \delta_{\{c\}} - \delta_{\{b,d\}} + \delta_{\{c,d\}} - \delta_{\{a,c,d\}} + \delta_{\{a,b,c,d\}}) \\
 &\quad - (\delta_{\emptyset} - \delta_{\{b\}} + \delta_{\{a,b\}} - \delta_{\{a,c\}} - \delta_{\{a,b,d\}} + \delta_{\{a,b,c,d\}}) \\
 &= (\delta_{\{b\}} - \delta_{\{a,b\}} + \delta_{\{a,d\}} - \delta_{\{b,d\}} - \delta_{\{a,c,d\}} + \delta_{\{a,b,c,d\}}) \\
 &\quad - (\delta_{\{c\}} - \delta_{\{a,c\}} + \delta_{\{a,d\}} - \delta_{\{c,d\}} - \delta_{\{a,b,d\}} + \delta_{\{a,b,c,d\}}) \\
 &= (\delta_{\{b\}} - \delta_{\{b,c\}} - \delta_{\{b,d\}} + \delta_{\{c,d\}} - \delta_{\{a,c,d\}} + \delta_{\{a,b,c,d\}}) \\
 &\quad - (\delta_{\{c\}} + \delta_{\{a,b\}} - \delta_{\{a,c\}} - \delta_{\{b,c\}} - \delta_{\{a,b,d\}} + \delta_{\{a,b,c,d\}}) \\
 &= (\delta_{\emptyset} - \delta_{\{c\}} - \delta_{\{d\}} + \delta_{\{a,c\}} + \delta_{\{c,d\}} - \delta_{\{a,b,c\}} - \delta_{\{a,c,d\}} + \delta_{\{a,b,c,d\}}) \\
 &\quad - (\delta_{\emptyset} - \delta_{\{b\}} - \delta_{\{d\}} + \delta_{\{a,b\}} + \delta_{\{b,d\}} - \delta_{\{a,b,c\}} - \delta_{\{a,b,d\}} + \delta_{\{a,b,c,d\}}) \\
 &= (\delta_{\emptyset} - \delta_{\{a\}} - \delta_{\{c\}} + \delta_{\{a,c\}} + \delta_{\{c,d\}} - \delta_{\{a,c,d\}} - \delta_{\{b,c,d\}} + \delta_{\{a,b,c,d\}}) \\
 &\quad - (\delta_{\emptyset} - \delta_{\{a\}} - \delta_{\{b\}} + \delta_{\{a,b\}} + \delta_{\{b,d\}} - \delta_{\{a,b,d\}} - \delta_{\{b,c,d\}} + \delta_{\{a,b,c,d\}}) \\
 &= (\delta_{\{b\}} - \delta_{\{a,b\}} - \delta_{\{b,d\}} + \delta_{\{a,b,d\}}) \\
 &\quad - (\delta_{\{c\}} - \delta_{\{a,c\}} - \delta_{\{c,d\}} + \delta_{\{a,c,d\}})
 \end{aligned}$$

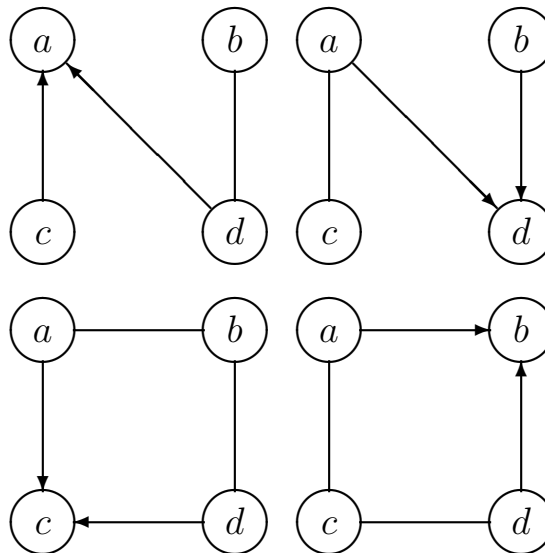

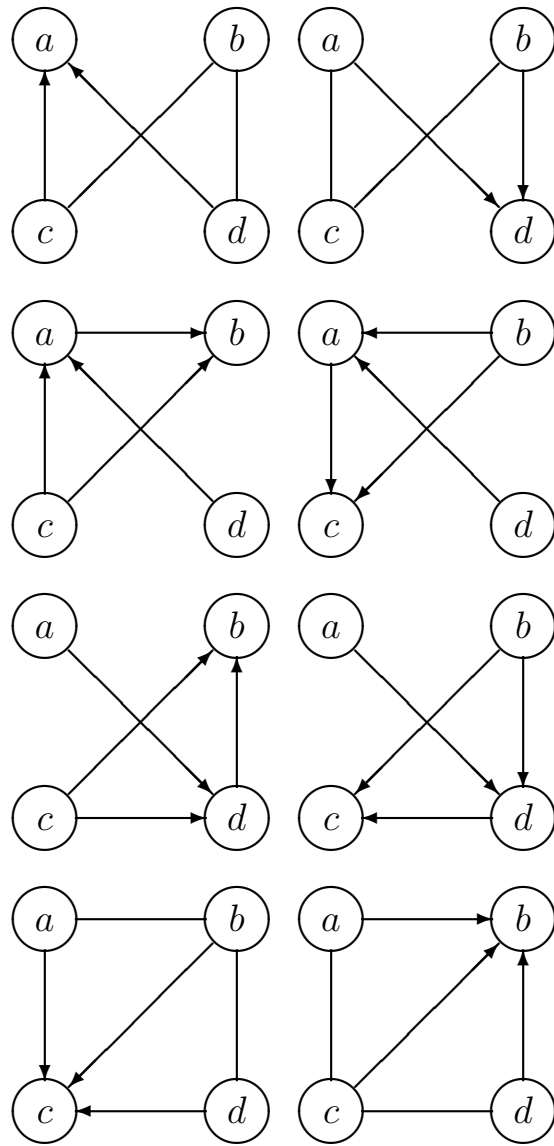

0.8.8.7 Differential inset (19)

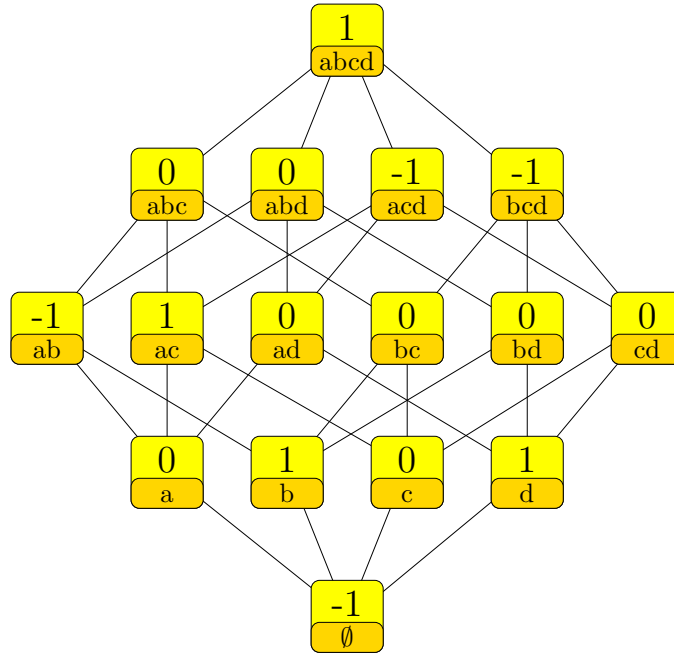

$$\begin{aligned}
 & -\delta_\emptyset + \delta_{\{b\}} + \delta_{\{d\}} - \delta_{\{a,b\}} + \delta_{\{a,c\}} - \delta_{\{a,c,d\}} - \delta_{\{b,c,d\}} + \delta_{\{a,b,c,d\}} \\
 &= -u_{\langle a,b|\emptyset \rangle} + u_{\langle a,c|\emptyset \rangle} - u_{\langle c,d|\emptyset \rangle} + u_{\langle a,b|cd \rangle} \\
 &= (\delta_\emptyset - \delta_{\{c\}} - \delta_{\{a,b\}} + \delta_{\{a,c\}} - \delta_{\{a,c,d\}} + \delta_{\{a,b,c,d\}}) \\
 &\quad - (+2\delta_\emptyset - \delta_{\{b\}} - \delta_{\{c\}} - \delta_{\{d\}} + \delta_{\{b,c,d\}})
 \end{aligned}$$

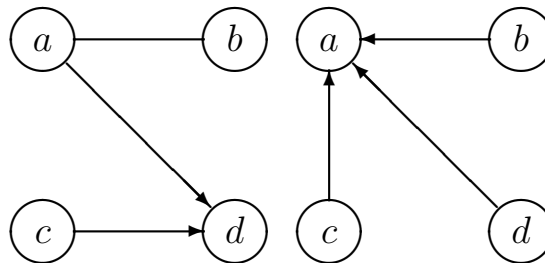

0.8.8.8 Differential inset (20)

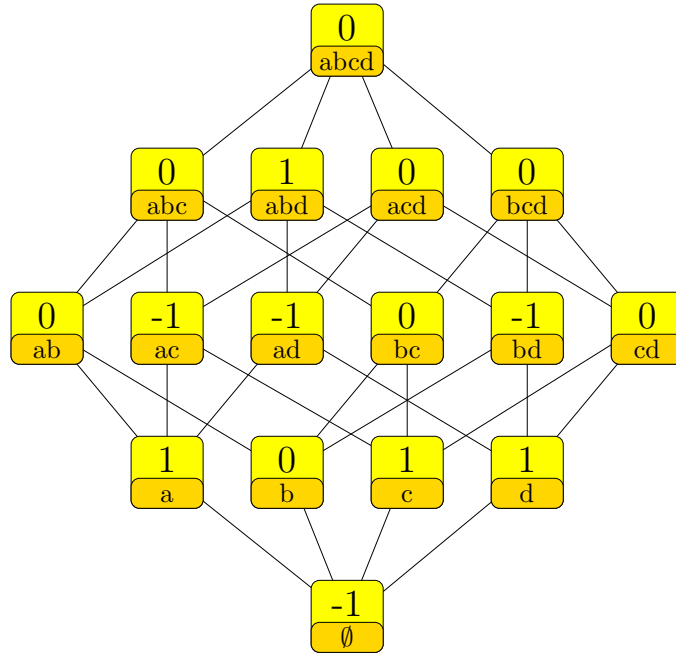

$$\begin{aligned}
 & -\delta_{\emptyset} + \delta_{\{a\}} + \delta_{\{c\}} + \delta_{\{d\}} - \delta_{\{a,c\}} - \delta_{\{a,d\}} - \delta_{\{b,d\}} + \delta_{\{a,b,d\}} \\
 &= -u_{\langle a,c|\emptyset \rangle} + u_{\langle a,b|d \rangle} \\
 &= (\delta_{\emptyset} + \delta_{\{a\}} - \delta_{\{b\}} - \delta_{\{a,c\}} - \delta_{\{a,d\}} + \delta_{\{a,b,c,d\}}) \\
 &\quad - (+2\delta_{\emptyset} - \delta_{\{b\}} - \delta_{\{c\}} - \delta_{\{d\}} + \delta_{\{b,d\}} - \delta_{\{a,b,d\}} + \delta_{\{a,b,c,d\}}) \\
 &= (\delta_{\{d\}} + \delta_{\{a,b\}} - \delta_{\{a,d\}} - \delta_{\{b,d\}} - \delta_{\{a,b,c\}} + \delta_{\{a,b,c,d\}}) \\
 &\quad - (\delta_{\emptyset} - \delta_{\{a\}} - \delta_{\{c\}} + \delta_{\{a,b\}} + \delta_{\{a,c\}} - \delta_{\{a,b,c\}} - \delta_{\{a,b,d\}} + \delta_{\{a,b,c,d\}}) \\
 &= (\delta_{\{d\}} - \delta_{\{a,d\}} - \delta_{\{b,d\}} + \delta_{\{a,b,d\}}) \\
 &\quad - (\delta_{\emptyset} - \delta_{\{a\}} - \delta_{\{c\}} + \delta_{\{a,c\}})
 \end{aligned}$$

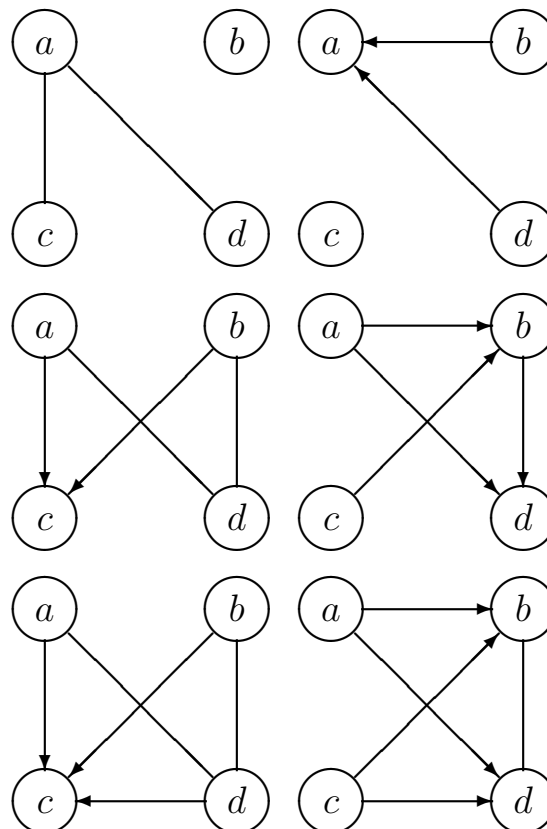

0.8.8.9 Differential inset (21)

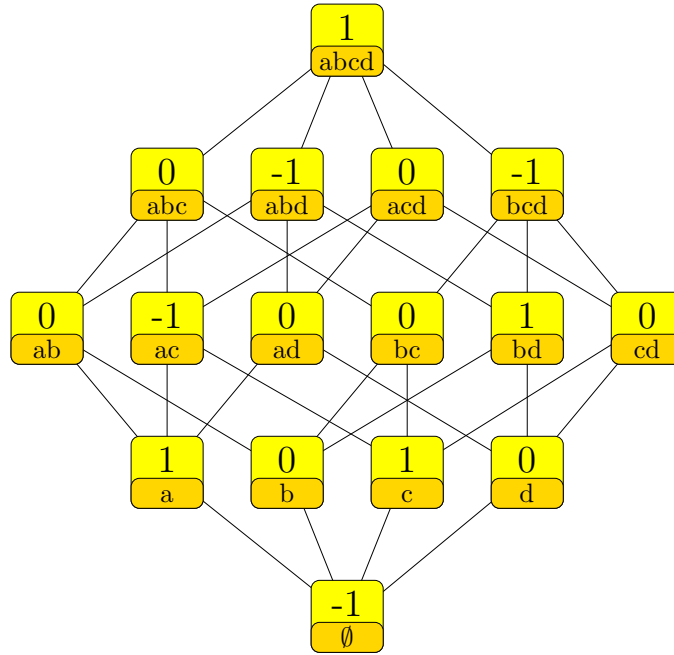

$$\begin{aligned}
 & -\delta_\emptyset + \delta_{\{a\}} + \delta_{\{c\}} - \delta_{\{a,c\}} + \delta_{\{b,d\}} - \delta_{\{a,b,d\}} - \delta_{\{b,c,d\}} + \delta_{\{a,b,c,d\}} \\
 &= -u_{\langle a,c|\emptyset} + u_{\langle a,c|bd} \\
 &= (\delta_{\{c\}} - \delta_{\{a,c\}} - \delta_{\{b,c,d\}} + \delta_{\{a,b,c,d\}}) \\
 &\quad - (\delta_\emptyset - \delta_{\{a\}} - \delta_{\{b,d\}} + \delta_{\{a,b,d\}}) \\
 &= (\delta_{\{b,d\}} - \delta_{\{a,b,d\}} - \delta_{\{b,c,d\}} + \delta_{\{a,b,c,d\}}) \\
 &\quad - (\delta_\emptyset - \delta_{\{a\}} - \delta_{\{c\}} + \delta_{\{a,c\}})
 \end{aligned}$$

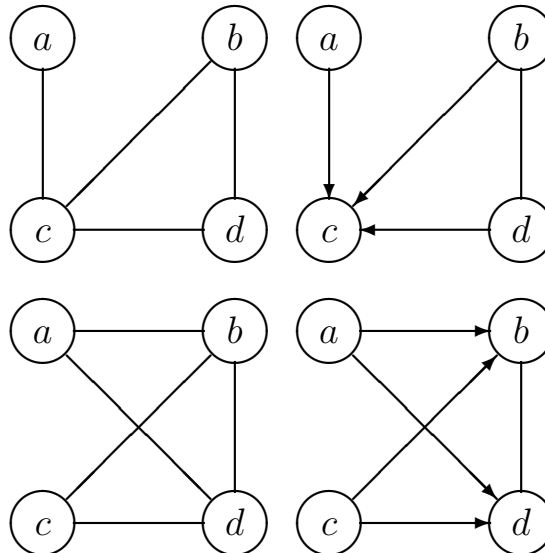



0.8.8.10 Differential imset (22)

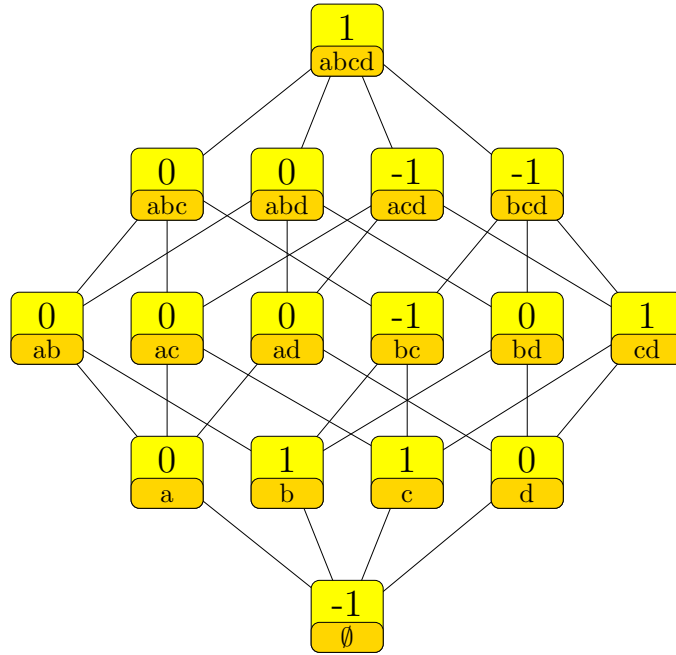

$$\begin{aligned}
 & -\delta_{\emptyset} + \delta_{\{b\}} + \delta_{\{c\}} - \delta_{\{b,c\}} + \delta_{\{c,d\}} - \delta_{\{a,c,d\}} - \delta_{\{b,c,d\}} + \delta_{\{a,b,c,d\}} \\
 &= -u_{\langle b,c|\emptyset \rangle} + u_{\langle a,b|cd \rangle} \\
 &= (\delta_{\emptyset} - \delta_{\{d\}} - \delta_{\{b,c\}} + \delta_{\{c,d\}} - \delta_{\{a,c,d\}} + \delta_{\{a,b,c,d\}}) \\
 &\quad - (+2\delta_{\emptyset} - \delta_{\{b\}} - \delta_{\{c\}} - \delta_{\{d\}} + \delta_{\{b,c,d\}}) \\
 &= (\delta_{\{b\}} - \delta_{\{b,c\}} - \delta_{\{b,d\}} + \delta_{\{c,d\}} - \delta_{\{a,c,d\}} + \delta_{\{a,b,c,d\}}) \\
 &\quad - (\delta_{\emptyset} - \delta_{\{c\}} - \delta_{\{b,d\}} + \delta_{\{b,c,d\}}) \\
 &= (\delta_{\{c,d\}} - \delta_{\{a,c,d\}} - \delta_{\{b,c,d\}} + \delta_{\{a,b,c,d\}}) \\
 &\quad - (\delta_{\emptyset} - \delta_{\{b\}} - \delta_{\{c\}} + \delta_{\{b,c\}})
 \end{aligned}$$

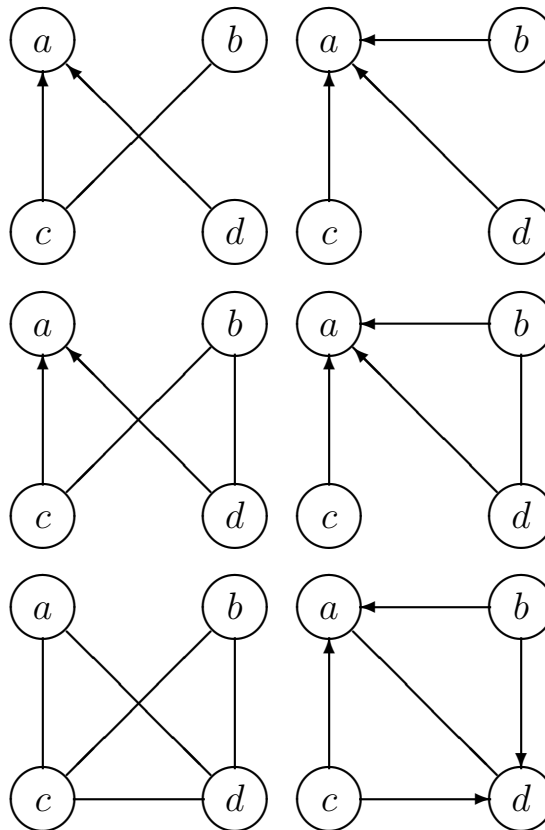

### 0.10 Squared Euclidean length 10

#### 0.10.7 Number of nonzero values 7

##### 0.10.7.1 Differential imset (23)

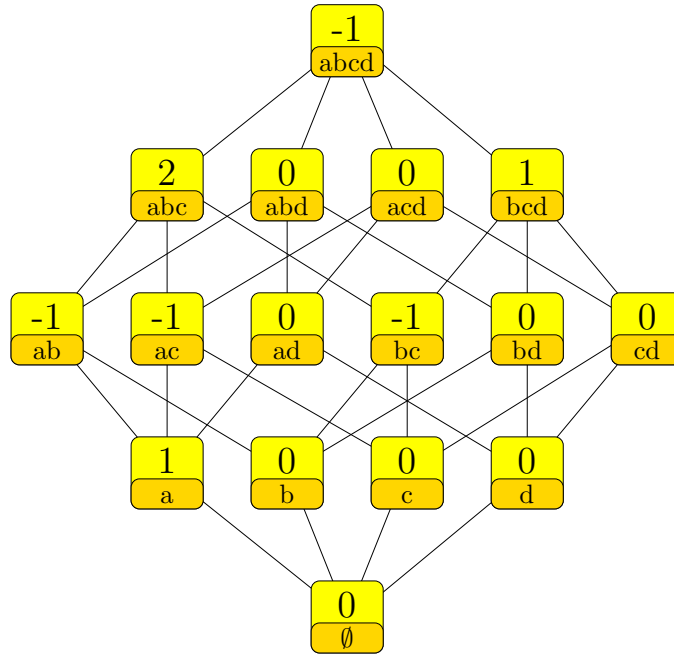

$$\begin{aligned}
 & \delta_{\{a\}} - \delta_{\{a,b\}} - \delta_{\{a,c\}} - \delta_{\{b,c\}} + 2\delta_{\{a,b,c\}} + \delta_{\{b,c,d\}} - \delta_{\{a,b,c,d\}} \\
 &= -u_{\langle a,d|bc \rangle} + u_{\langle b,c|a \rangle} \\
 &= (\delta_{\emptyset} - \delta_{\{c\}} - \delta_{\{a,b\}} + \delta_{\{a,b,c\}}) \\
 &\quad - (\delta_{\emptyset} - \delta_{\{a\}} - \delta_{\{c\}} + \delta_{\{a,c\}} + \delta_{\{b,c\}} - \delta_{\{a,b,c\}} - \delta_{\{b,c,d\}} + \delta_{\{a,b,c,d\}}) \\
 &= (\delta_{\{a\}} - \delta_{\{a,b\}} - \delta_{\{a,c\}} + \delta_{\{a,b,c\}}) \\
 &\quad - (\delta_{\{b,c\}} - \delta_{\{a,b,c\}} - \delta_{\{b,c,d\}} + \delta_{\{a,b,c,d\}})
 \end{aligned}$$

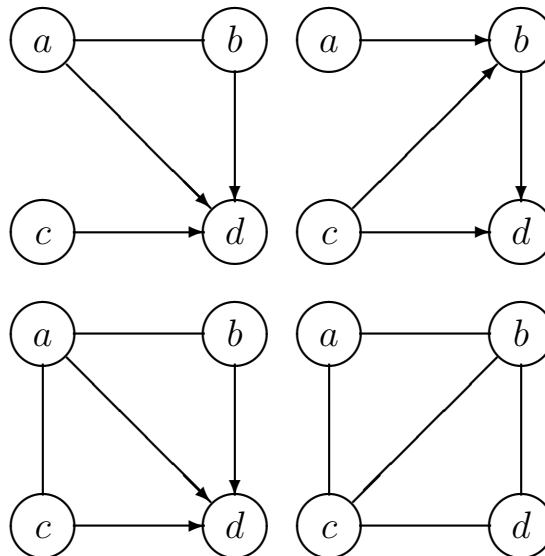

0.10.7.2 Differential imset (24)

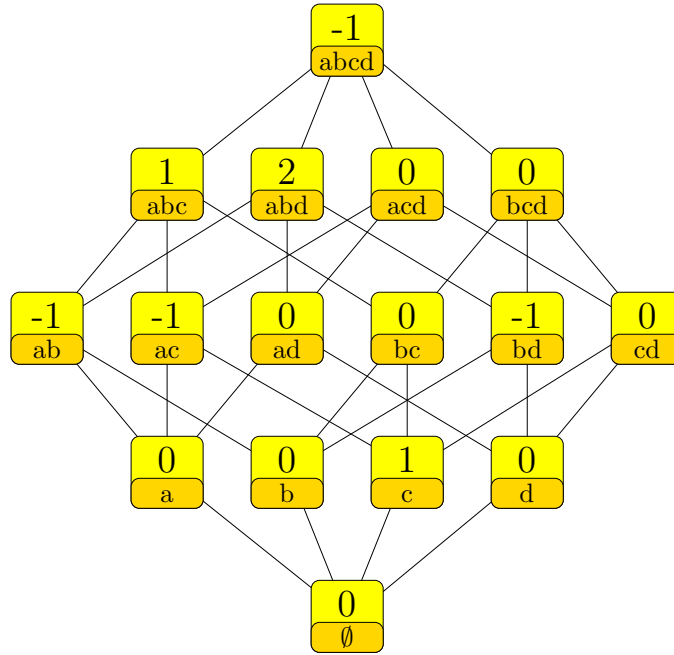

$$\begin{aligned}
 & \delta_{\{c\}} - \delta_{\{a,b\}} - \delta_{\{a,c\}} - \delta_{\{b,d\}} + \delta_{\{a,b,c\}} + 2\delta_{\{a,b,d\}} - \delta_{\{a,b,c,d\}} \\
 &= u_{\langle a,b|\emptyset \rangle} - u_{\langle a,c|\emptyset \rangle} - u_{\langle c,d|ab \rangle} + u_{\langle a,d|b \rangle} \\
 &= (\delta_{\emptyset} - \delta_{\{a\}} - \delta_{\{b,d\}} + \delta_{\{a,b,d\}}) \\
 &\quad - (\delta_{\emptyset} - \delta_{\{a\}} - \delta_{\{c\}} + \delta_{\{a,b\}} + \delta_{\{a,c\}} - \delta_{\{a,b,c\}} - \delta_{\{a,b,d\}} + \delta_{\{a,b,c,d\}})
 \end{aligned}$$

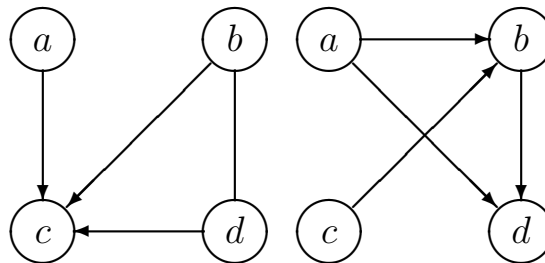

0.10.7.3 Differential imset (25)

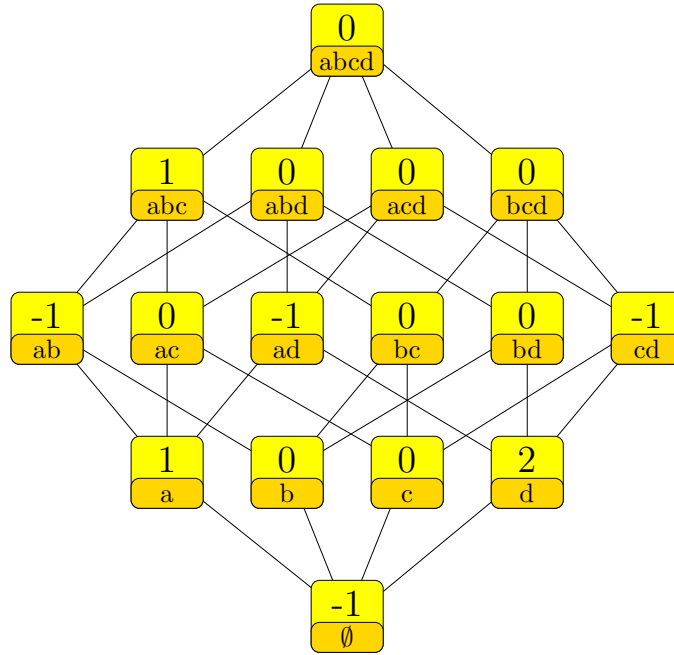

$$\begin{aligned}
 & -\delta_\emptyset + \delta_{\{a\}} + 2\delta_{\{d\}} - \delta_{\{a,b\}} - \delta_{\{a,d\}} - \delta_{\{c,d\}} + \delta_{\{a,b,c\}} \\
 &= u_{\langle a,c|\emptyset \rangle} - u_{\langle a,d|\emptyset \rangle} - u_{\langle c,d|\emptyset \rangle} + u_{\langle b,c|a \rangle} \\
 &= (\delta_\emptyset - \delta_{\{b\}} + \delta_{\{d\}} - \delta_{\{a,d\}} - \delta_{\{c,d\}} + \delta_{\{a,b,c,d\}}) \\
 &\quad - (+2\delta_\emptyset - \delta_{\{a\}} - \delta_{\{b\}} - \delta_{\{d\}} + \delta_{\{a,b\}} - \delta_{\{a,b,c\}} + \delta_{\{a,b,c,d\}})
 \end{aligned}$$

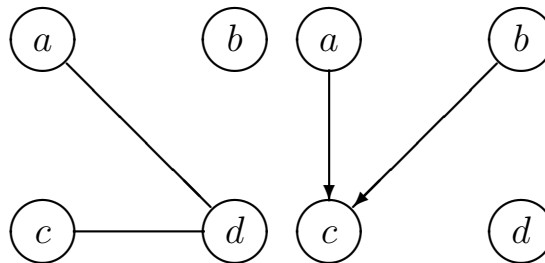

0.10.7.4 Differential imset (26)

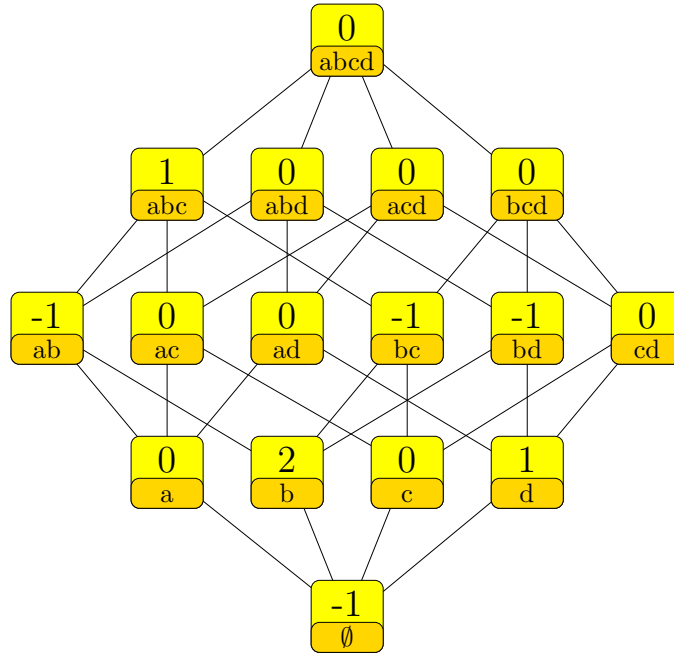

$$\begin{aligned}
 & -\delta_\emptyset + 2\delta_{\{b\}} + \delta_{\{d\}} - \delta_{\{a,b\}} - \delta_{\{b,c\}} - \delta_{\{b,d\}} + \delta_{\{a,b,c\}} \\
 &= -u_{\langle b,d|\emptyset \rangle} + u_{\langle a,c|b \rangle} \\
 &= (\delta_\emptyset + \delta_{\{b\}} - \delta_{\{c\}} - \delta_{\{a,b\}} - \delta_{\{b,d\}} + \delta_{\{a,b,c,d\}}) \\
 &\quad - (+2\delta_\emptyset - \delta_{\{b\}} - \delta_{\{c\}} - \delta_{\{d\}} + \delta_{\{b,c\}} - \delta_{\{a,b,c\}} + \delta_{\{a,b,c,d\}}) \\
 &= (\delta_{\{b\}} - \delta_{\{b,c\}} - \delta_{\{a,b,d\}} + \delta_{\{a,b,c,d\}}) \\
 &\quad - (\delta_\emptyset - \delta_{\{b\}} - \delta_{\{d\}} + \delta_{\{a,b\}} + \delta_{\{b,d\}} - \delta_{\{a,b,c\}} - \delta_{\{a,b,d\}} + \delta_{\{a,b,c,d\}})
 \end{aligned}$$

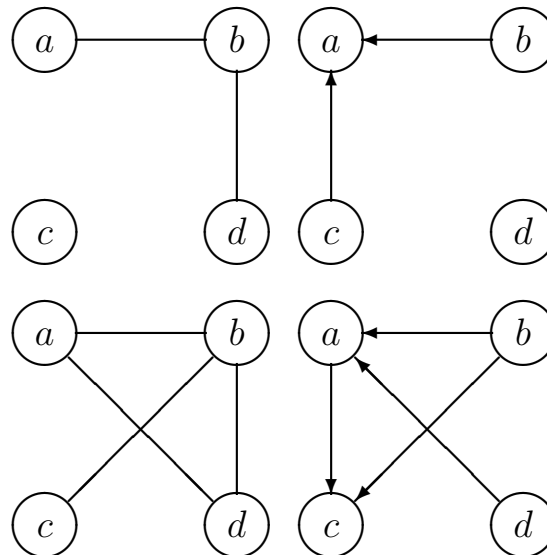

0.10.7.5 Differential imset (27)

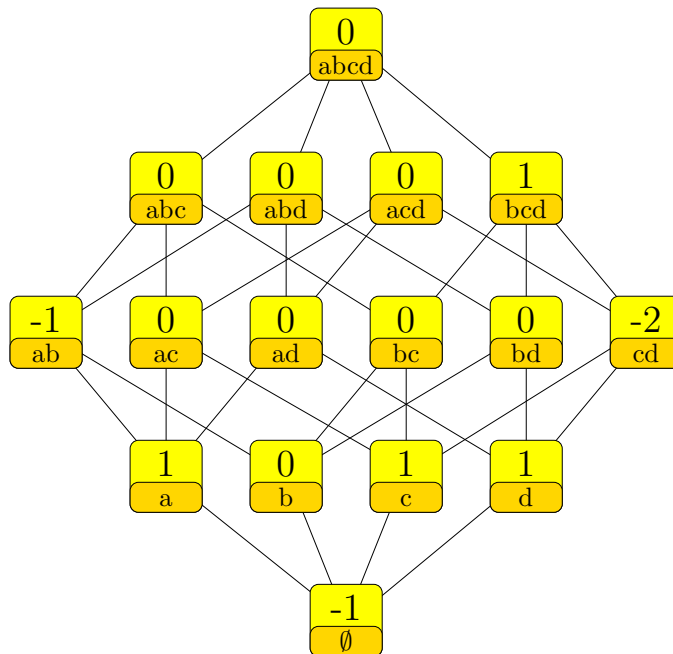

$$\begin{aligned}
 & -\delta_\emptyset + \delta_{\{a\}} + \delta_{\{c\}} + \delta_{\{d\}} - \delta_{\{a,b\}} - 2\delta_{\{c,d\}} + \delta_{\{b,c,d\}} \\
 &= -u_{\langle a,b|\emptyset \rangle} + u_{\langle b,c|\emptyset \rangle} - u_{\langle c,d|\emptyset \rangle} + u_{\langle b,d|c \rangle} \\
 &= (\delta_\emptyset - \delta_{\{a,b\}} - \delta_{\{c,d\}} + \delta_{\{a,b,c,d\}}) \\
 &\quad - (+2\delta_\emptyset - \delta_{\{a\}} - \delta_{\{c\}} - \delta_{\{d\}} + \delta_{\{c,d\}} - \delta_{\{b,c,d\}} + \delta_{\{a,b,c,d\}})
 \end{aligned}$$

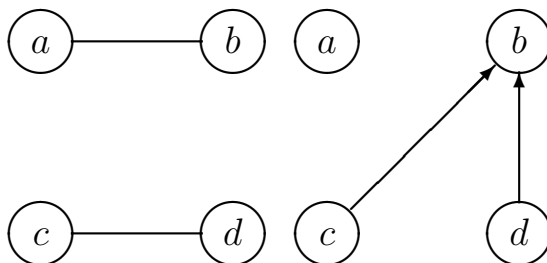

0.10.7.6 Differential imset (28)

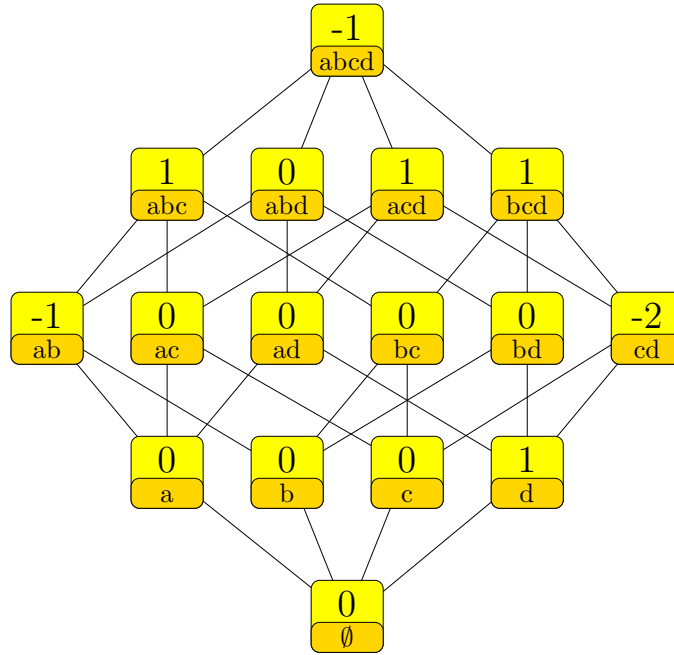

$$\begin{aligned}
 & \delta_{\{d\}} - \delta_{\{a,b\}} - 2\delta_{\{c,d\}} + \delta_{\{a,b,c\}} + \delta_{\{a,c,d\}} + \delta_{\{b,c,d\}} - \delta_{\{a,b,c,d\}} \\
 &= u_{\langle a,c|\emptyset} - u_{\langle c,d|\emptyset} - u_{\langle a,b|cd} + u_{\langle b,c|a} \\
 &= (\delta_{\emptyset} - \delta_{\{c\}} - \delta_{\{a,b\}} + \delta_{\{a,b,c\}}) \\
 &\quad - (\delta_{\emptyset} - \delta_{\{c\}} - \delta_{\{d\}} + 2\delta_{\{c,d\}} - \delta_{\{a,c,d\}} - \delta_{\{b,c,d\}} + \delta_{\{a,b,c,d\}})
 \end{aligned}$$

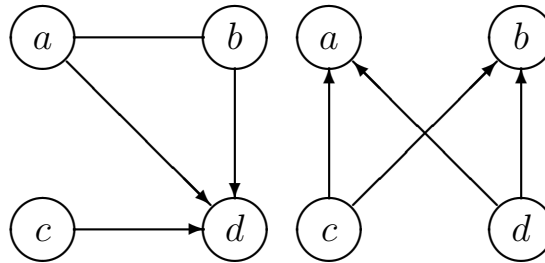

0.10.7.7 Differential imset (29)

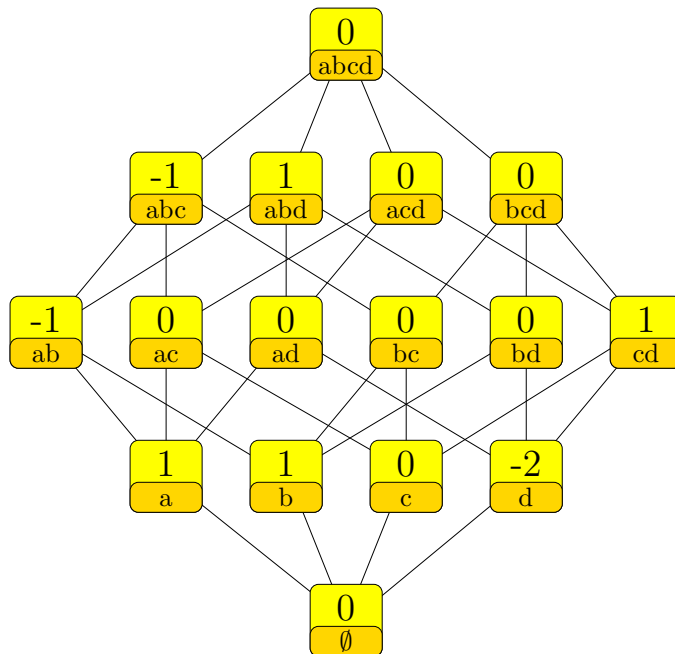

$$\begin{aligned}
 & \delta_{\{a\}} + \delta_{\{b\}} - 2\delta_{\{d\}} - \delta_{\{a,b\}} + \delta_{\{c,d\}} - \delta_{\{a,b,c\}} + \delta_{\{a,b,d\}} \\
 &= -u_{\langle a,b|\emptyset \rangle} + u_{\langle a,d|\emptyset \rangle} + u_{\langle c,d|ab \rangle} - u_{\langle b,c|ad \rangle} + u_{\langle b,d|a \rangle} - u_{\langle a,c|d \rangle} \\
 &= (\delta_{\emptyset} - \delta_{\{d\}} - \delta_{\{a,b,c\}} + \delta_{\{a,b,c,d\}}) \\
 &\quad - (\delta_{\emptyset} - \delta_{\{a\}} - \delta_{\{b\}} + \delta_{\{d\}} + \delta_{\{a,b\}} - \delta_{\{c,d\}} - \delta_{\{a,b,d\}} + \delta_{\{a,b,c,d\}})
 \end{aligned}$$

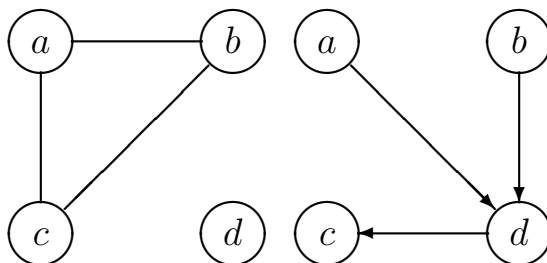



0.10.7.8 Differential imset (30)

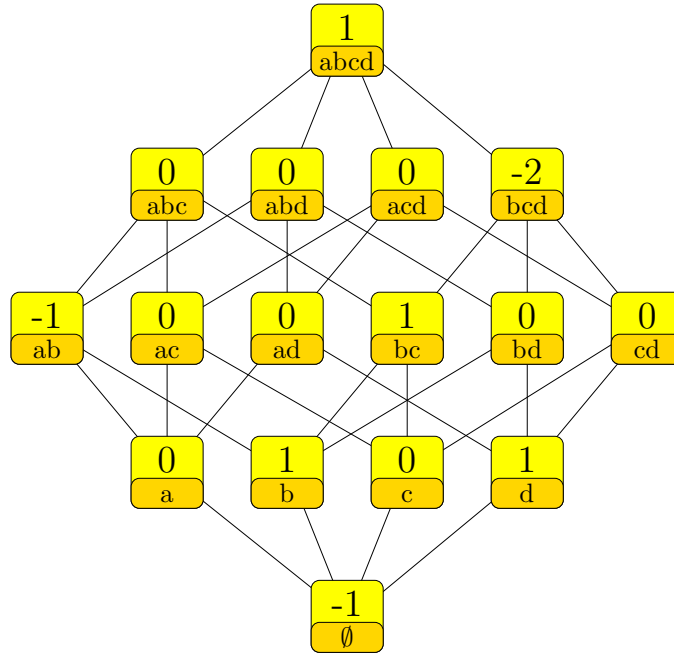

$$\begin{aligned}
 & -\delta_\emptyset + \delta_{\{b\}} + \delta_{\{d\}} - \delta_{\{a,b\}} + \delta_{\{b,c\}} - 2\delta_{\{b,c,d\}} + \delta_{\{a,b,c,d\}} \\
 &= -u_{\langle b,d|\emptyset \rangle} - u_{\langle c,d|ab \rangle} + u_{\langle a,d|bc \rangle} + u_{\langle a,c|bd \rangle} \\
 &= (\delta_\emptyset - \delta_{\{c\}} - \delta_{\{a,b\}} + \delta_{\{b,c\}} - \delta_{\{b,c,d\}} + \delta_{\{a,b,c,d\}}) \\
 &\quad - (+2\delta_\emptyset - \delta_{\{b\}} - \delta_{\{c\}} - \delta_{\{d\}} + \delta_{\{b,c,d\}})
 \end{aligned}$$

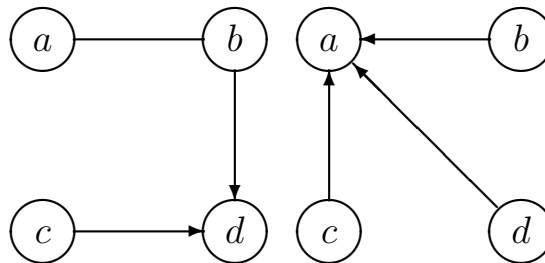

0.10.7.9 Differential imset (31)

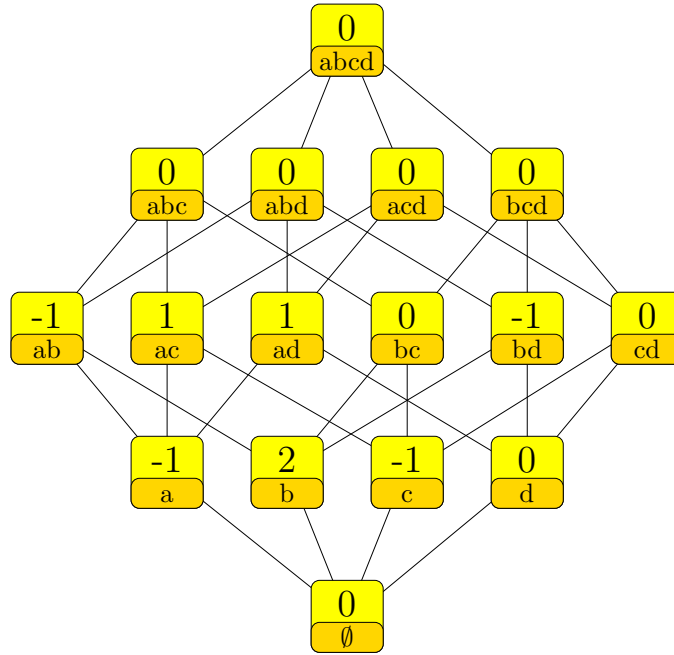

$$\begin{aligned}
 & -\delta_{\{a\}} + 2\delta_{\{b\}} - \delta_{\{c\}} - \delta_{\{a,b\}} + \delta_{\{a,c\}} + \delta_{\{a,d\}} - \delta_{\{b,d\}} \\
 &= -u_{\langle a,b|\emptyset \rangle} + u_{\langle a,c|\emptyset \rangle} - u_{\langle b,d|a \rangle} + u_{\langle a,d|b \rangle} \\
 &= (\delta_{\emptyset} + \delta_{\{b\}} - \delta_{\{c\}} - \delta_{\{a,b\}} - \delta_{\{b,d\}} + \delta_{\{a,b,c,d\}}) \\
 &\quad - (\delta_{\emptyset} + \delta_{\{a\}} - \delta_{\{b\}} - \delta_{\{a,c\}} - \delta_{\{a,d\}} + \delta_{\{a,b,c,d\}})
 \end{aligned}$$

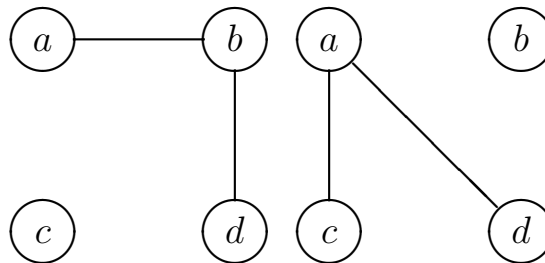

0.10.7.10 Differential imset (32)

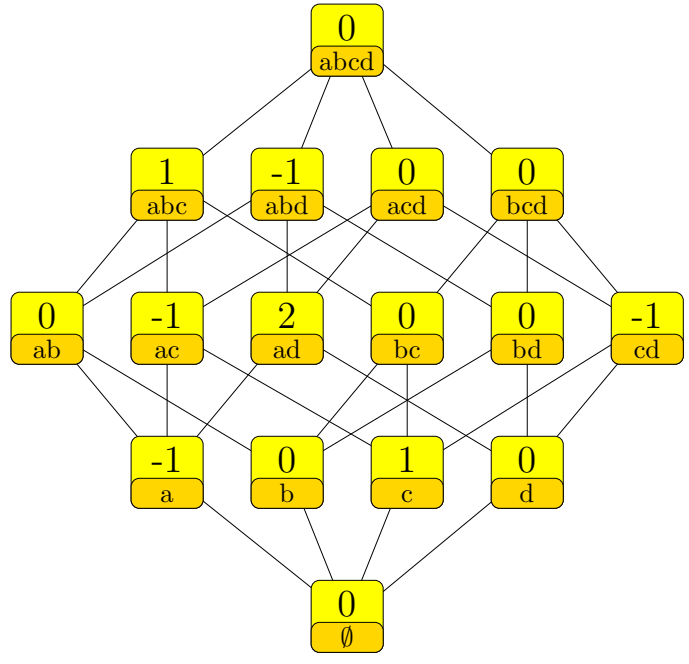

$$\begin{aligned}
 & -\delta_{\{a\}} + \delta_{\{c\}} - \delta_{\{a,c\}} + 2\delta_{\{a,d\}} - \delta_{\{c,d\}} + \delta_{\{a,b,c\}} - \delta_{\{a,b,d\}} \\
 &= -u_{\langle c,d|ab \rangle} + u_{\langle b,c|ad \rangle} - u_{\langle b,d|a \rangle} + u_{\langle a,d|c \rangle} \\
 &= (\delta_{\emptyset} - \delta_{\{a\}} + \delta_{\{a,d\}} - \delta_{\{c,d\}} - \delta_{\{a,b,d\}} + \delta_{\{a,b,c,d\}}) \\
 &\quad - (\delta_{\emptyset} - \delta_{\{c\}} + \delta_{\{a,c\}} - \delta_{\{a,d\}} - \delta_{\{a,b,c\}} + \delta_{\{a,b,c,d\}})
 \end{aligned}$$

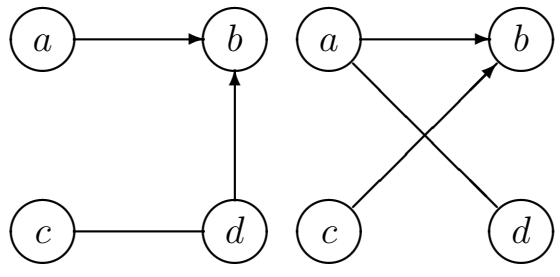

0.10.7.11 Differential imset (33)

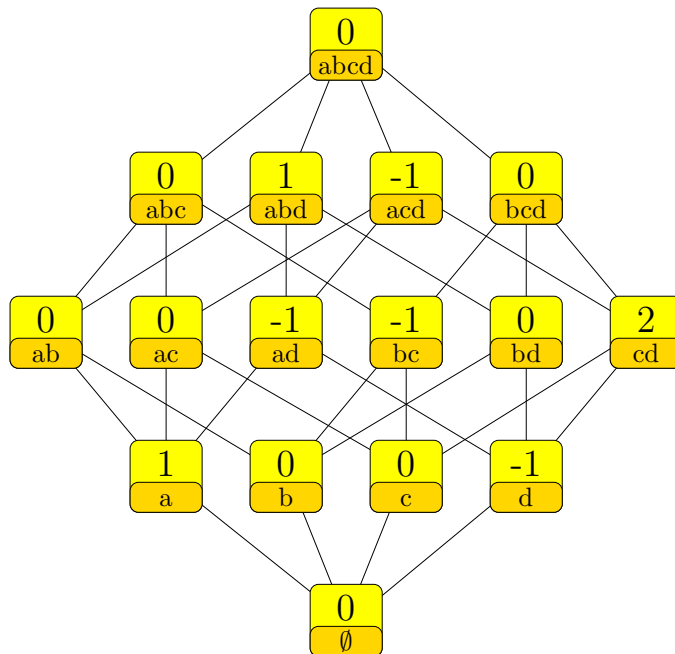

$$\begin{aligned}
 & \delta_{\{a\}} - \delta_{\{d\}} - \delta_{\{a,d\}} - \delta_{\{b,c\}} + 2\delta_{\{c,d\}} + \delta_{\{a,b,d\}} - \delta_{\{a,c,d\}} \\
 &= -u_{\langle a,c|\emptyset \rangle} + u_{\langle b,d|\emptyset \rangle} - u_{\langle b,c|ad \rangle} + u_{\langle a,b|cd \rangle} - u_{\langle a,d|c \rangle} + u_{\langle c,d|b \rangle} \\
 &= (\delta_{\emptyset} - \delta_{\{d\}} - \delta_{\{b,c\}} + \delta_{\{c,d\}} - \delta_{\{a,c,d\}} + \delta_{\{a,b,c,d\}}) \\
 &\quad - (\delta_{\emptyset} - \delta_{\{a\}} + \delta_{\{a,d\}} - \delta_{\{c,d\}} - \delta_{\{a,b,d\}} + \delta_{\{a,b,c,d\}})
 \end{aligned}$$

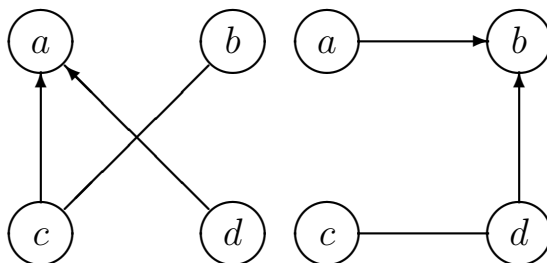

0.10.7.12 Differential imset (34)

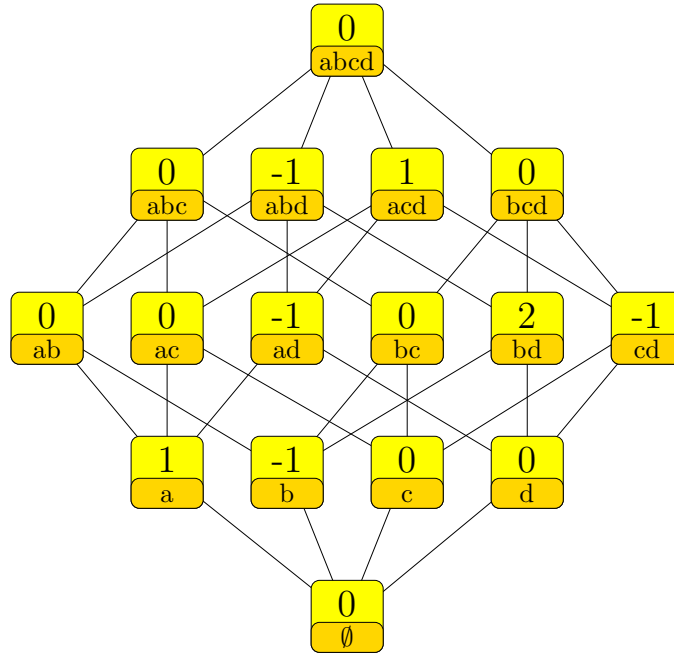

$$\begin{aligned}
 & \delta_{\{a\}} - \delta_{\{b\}} - \delta_{\{a,d\}} + 2\delta_{\{b,d\}} - \delta_{\{c,d\}} - \delta_{\{a,b,d\}} + \delta_{\{a,c,d\}} \\
 &= -u_{\langle a,b|\emptyset \rangle} + u_{\langle b,d|\emptyset \rangle} - u_{\langle a,d|b \rangle} + u_{\langle a,c|d \rangle} \\
 &= (\delta_{\emptyset} - \delta_{\{b\}} + \delta_{\{b,d\}} - \delta_{\{c,d\}} - \delta_{\{a,b,d\}} + \delta_{\{a,b,c,d\}}) \\
 &\quad - (\delta_{\emptyset} - \delta_{\{a\}} + \delta_{\{a,d\}} - \delta_{\{b,d\}} - \delta_{\{a,c,d\}} + \delta_{\{a,b,c,d\}})
 \end{aligned}$$

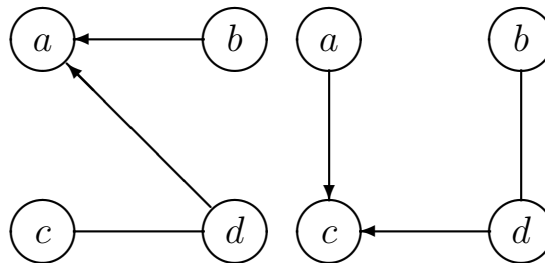

0.10.7.13 Differential imset (35)

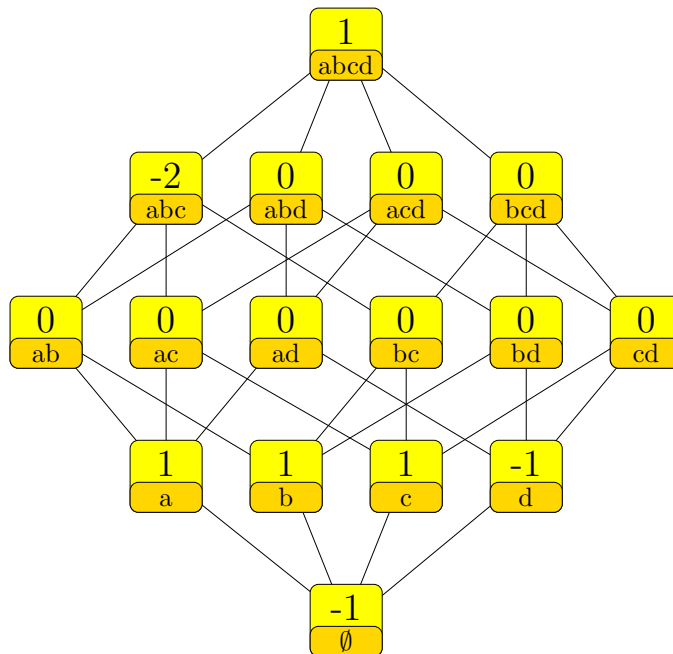

$$\begin{aligned}
 & -\delta_\emptyset + \delta_{\{a\}} + \delta_{\{b\}} + \delta_{\{c\}} - \delta_{\{d\}} - 2\delta_{\{a,b,c\}} + \delta_{\{a,b,c,d\}} \\
 &= -u_{\langle a,b|\emptyset \rangle} - u_{\langle a,c|\emptyset \rangle} + u_{\langle a,d|\emptyset \rangle} + u_{\langle c,d|ab \rangle} - u_{\langle b,c|a \rangle} + u_{\langle b,d|a \rangle} \\
 &= (\delta_\emptyset - \delta_{\{d\}} - \delta_{\{a,b,c\}} + \delta_{\{a,b,c,d\}}) \\
 &\quad - (+2\delta_\emptyset - \delta_{\{a\}} - \delta_{\{b\}} - \delta_{\{c\}} + \delta_{\{a,b,c\}})
 \end{aligned}$$

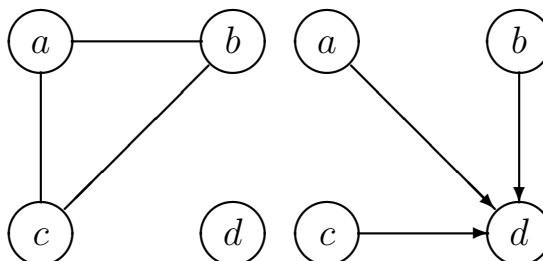

0.10.7.14 Differential imset (36)

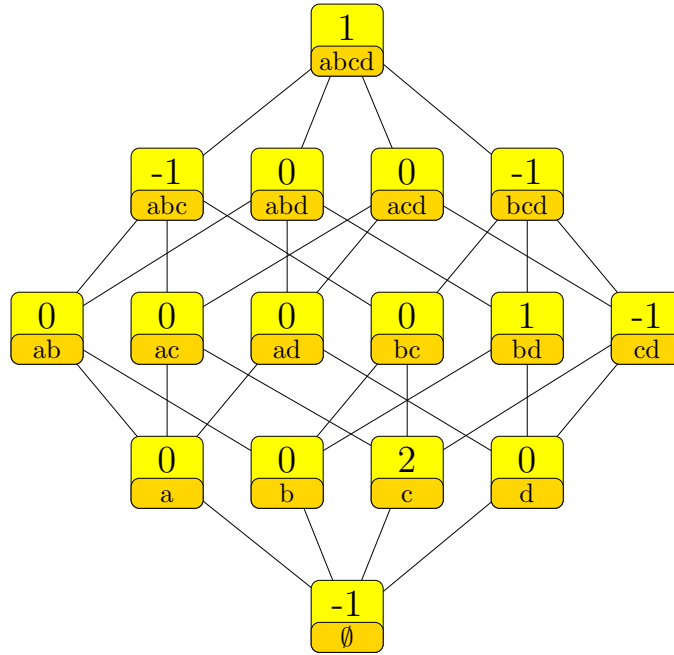

$$\begin{aligned}
 & -\delta_\emptyset + 2\delta_{\{c\}} + \delta_{\{b,d\}} - \delta_{\{c,d\}} - \delta_{\{a,b,c\}} - \delta_{\{b,c,d\}} + \delta_{\{a,b,c,d\}} \\
 &= -u_{\langle b,c|\emptyset \rangle} + u_{\langle b,d|ac \rangle} + u_{\langle a,d|c \rangle} - u_{\langle c,d|b \rangle} \\
 &= (\delta_{\{c\}} - \delta_{\{c,d\}} - \delta_{\{a,b,c\}} + \delta_{\{a,b,c,d\}}) \\
 &\quad - (\delta_\emptyset - \delta_{\{c\}} - \delta_{\{b,d\}} + \delta_{\{b,c,d\}})
 \end{aligned}$$

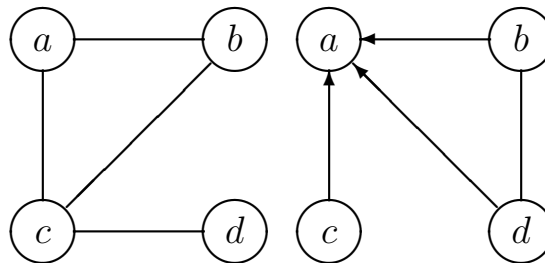

0.10.10 Number of nonzero values 10

0.10.10.1 Differential imset (37)

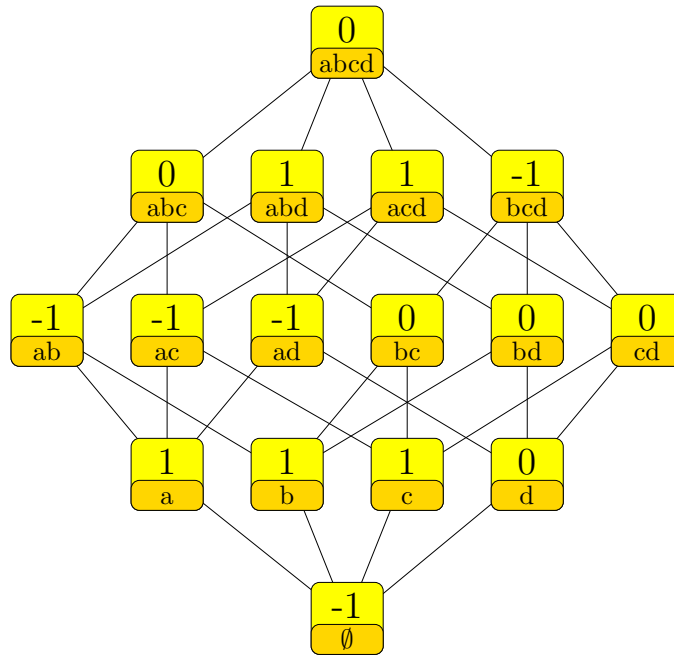

$$\begin{aligned}
 & -\delta_{\emptyset} + \delta_{\{a\}} + \delta_{\{b\}} + \delta_{\{c\}} - \delta_{\{a,b\}} - \delta_{\{a,c\}} - \delta_{\{a,d\}} + \delta_{\{a,b,d\}} + \delta_{\{a,c,d\}} - \delta_{\{b,c,d\}} \\
 &= -u_{\langle a,c|\emptyset \rangle} - u_{\langle b,c|ad \rangle} + u_{\langle a,d|bc \rangle} + u_{\langle a,c|b \rangle} \\
 &= (\delta_{\{b\}} - \delta_{\{a,b\}} - \delta_{\{b,c,d\}} + \delta_{\{a,b,c,d\}}) \\
 &\quad - (\delta_{\emptyset} - \delta_{\{a\}} - \delta_{\{c\}} + \delta_{\{a,c\}} + \delta_{\{a,d\}} - \delta_{\{a,b,d\}} - \delta_{\{a,c,d\}} + \delta_{\{a,b,c,d\}}) \\
 &= (\delta_{\{c\}} - \delta_{\{a,c\}} - \delta_{\{b,c,d\}} + \delta_{\{a,b,c,d\}}) \\
 &\quad - (\delta_{\emptyset} - \delta_{\{a\}} - \delta_{\{b\}} + \delta_{\{a,b\}} + \delta_{\{a,d\}} - \delta_{\{a,b,d\}} - \delta_{\{a,c,d\}} + \delta_{\{a,b,c,d\}})
 \end{aligned}$$

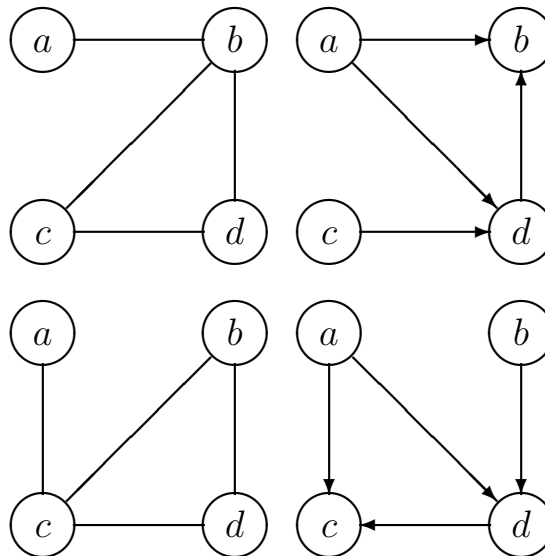



0.10.10.2 Differential imset (38)

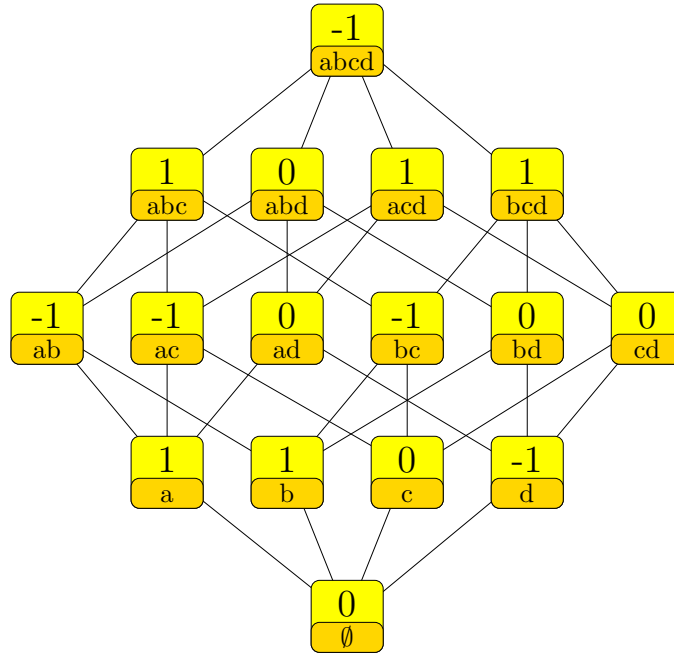

$$\begin{aligned}
 & \delta_{\{a\}} + \delta_{\{b\}} - \delta_{\{d\}} - \delta_{\{a,b\}} - \delta_{\{a,c\}} - \delta_{\{b,c\}} + \delta_{\{a,b,c\}} + \delta_{\{a,c,d\}} + \delta_{\{b,c,d\}} - \delta_{\{a,b,c,d\}} \\
 &= -u_{\langle a,b|\emptyset \rangle} + u_{\langle a,d|\emptyset \rangle} - u_{\langle a,d|bc \rangle} + u_{\langle c,d|a \rangle} \\
 &= (\delta_{\emptyset} - \delta_{\{d\}} - \delta_{\{a,c\}} + \delta_{\{a,c,d\}}) \\
 &\quad - (\delta_{\emptyset} - \delta_{\{a\}} - \delta_{\{b\}} + \delta_{\{a,b\}} + \delta_{\{b,c\}} - \delta_{\{a,b,c\}} - \delta_{\{b,c,d\}} + \delta_{\{a,b,c,d\}}) \\
 &= (\delta_{\emptyset} - \delta_{\{d\}} - \delta_{\{b,c\}} + \delta_{\{b,c,d\}}) \\
 &\quad - (\delta_{\emptyset} - \delta_{\{a\}} - \delta_{\{b\}} + \delta_{\{a,b\}} + \delta_{\{a,c\}} - \delta_{\{a,b,c\}} - \delta_{\{a,c,d\}} + \delta_{\{a,b,c,d\}})
 \end{aligned}$$

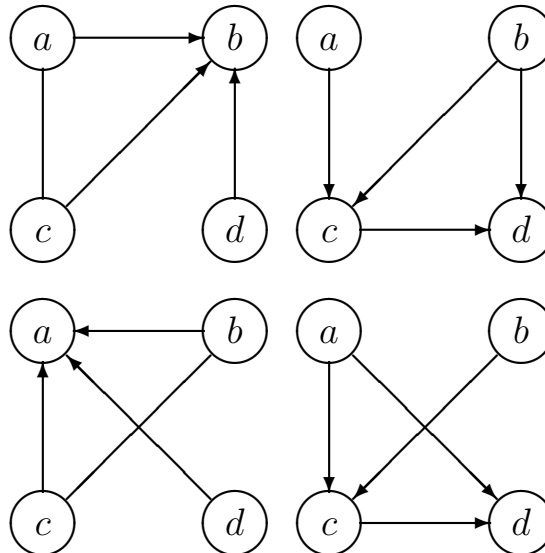

0.10.10.3 Differential imset (39)

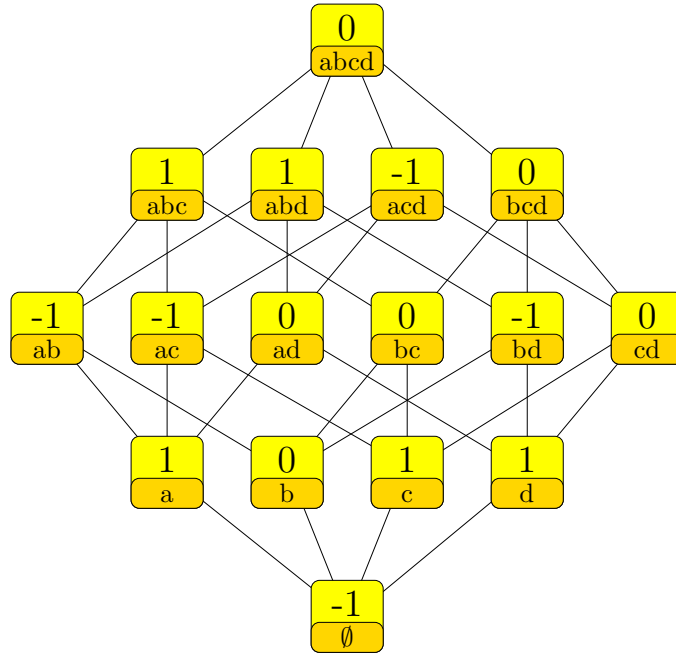

$$\begin{aligned}
 & -\delta_{\emptyset} + \delta_{\{a\}} + \delta_{\{c\}} + \delta_{\{d\}} - \delta_{\{a,b\}} - \delta_{\{a,c\}} - \delta_{\{b,d\}} + \delta_{\{a,b,c\}} + \delta_{\{a,b,d\}} - \delta_{\{a,c,d\}} \\
 & = -u_{\langle a,c|\emptyset \rangle} - u_{\langle c,d|ab \rangle} + u_{\langle b,c|ad \rangle} + u_{\langle a,b|d \rangle} \\
 & = (\delta_{\{d\}} - \delta_{\{b,d\}} - \delta_{\{a,c,d\}} + \delta_{\{a,b,c,d\}}) \\
 & \quad - (\delta_{\emptyset} - \delta_{\{a\}} - \delta_{\{c\}} + \delta_{\{a,b\}} + \delta_{\{a,c\}} - \delta_{\{a,b,c\}} - \delta_{\{a,b,d\}} + \delta_{\{a,b,c,d\}})
 \end{aligned}$$

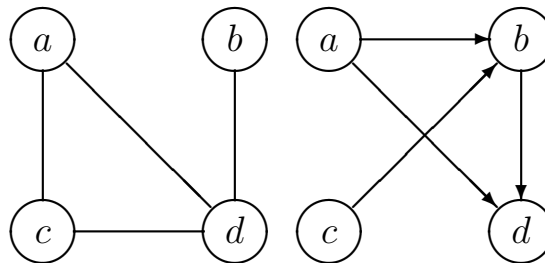

0.10.10.4 Differential imset (40)

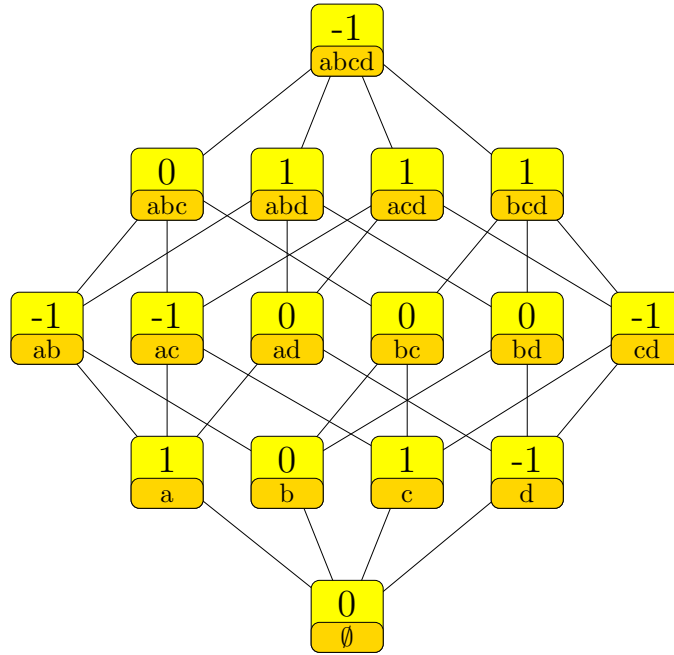

$$\begin{aligned}
 & \delta_{\{a\}} + \delta_{\{c\}} - \delta_{\{d\}} - \delta_{\{a,b\}} - \delta_{\{a,c\}} - \delta_{\{c,d\}} + \delta_{\{a,b,d\}} + \delta_{\{a,c,d\}} + \delta_{\{b,c,d\}} - \delta_{\{a,b,c,d\}} \\
 &= -u_{\langle a,c|\emptyset \rangle} + u_{\langle a,d|\emptyset \rangle} - u_{\langle a,b|cd \rangle} + u_{\langle b,d|a \rangle} \\
 &= (\delta_{\emptyset} - \delta_{\{d\}} - \delta_{\{a,b\}} + \delta_{\{a,b,d\}}) \\
 &\quad - (\delta_{\emptyset} - \delta_{\{a\}} - \delta_{\{c\}} + \delta_{\{a,c\}} + \delta_{\{c,d\}} - \delta_{\{a,c,d\}} - \delta_{\{b,c,d\}} + \delta_{\{a,b,c,d\}})
 \end{aligned}$$

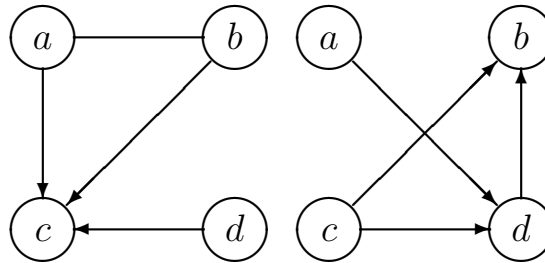

0.10.10.5 Differential imset (41)

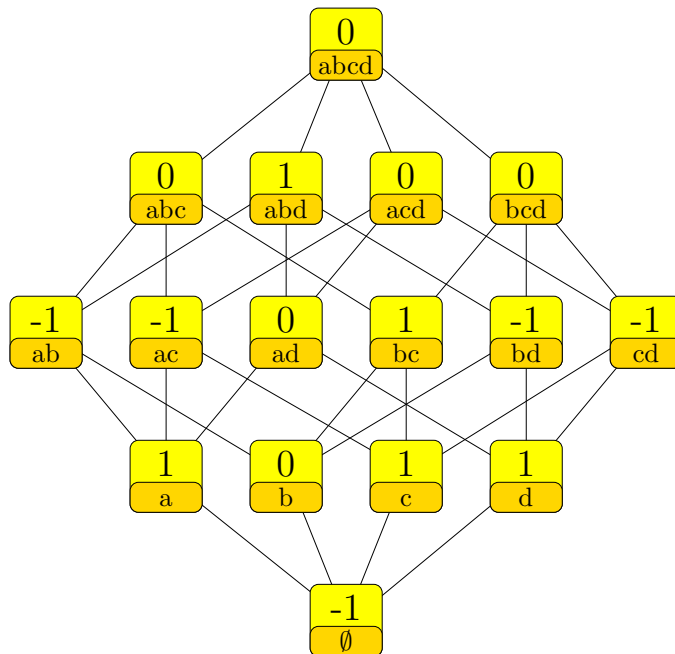

$$\begin{aligned}
 & -\delta_{\emptyset} + \delta_{\{a\}} + \delta_{\{c\}} + \delta_{\{d\}} - \delta_{\{a,b\}} - \delta_{\{a,c\}} + \delta_{\{b,c\}} - \delta_{\{b,d\}} - \delta_{\{c,d\}} + \delta_{\{a,b,d\}} \\
 & = -u_{\langle a,c|\emptyset} + u_{\langle b,c|\emptyset} - u_{\langle c,d|\emptyset} + u_{\langle a,d|b} \\
 & = (\delta_{\{a\}} + \delta_{\{c\}} - \delta_{\{a,b\}} - \delta_{\{a,c\}} - \delta_{\{c,d\}} + \delta_{\{a,b,c,d\}}) \\
 & \quad - (\delta_{\emptyset} - \delta_{\{d\}} - \delta_{\{b,c\}} + \delta_{\{b,d\}} - \delta_{\{a,b,d\}} + \delta_{\{a,b,c,d\}})
 \end{aligned}$$

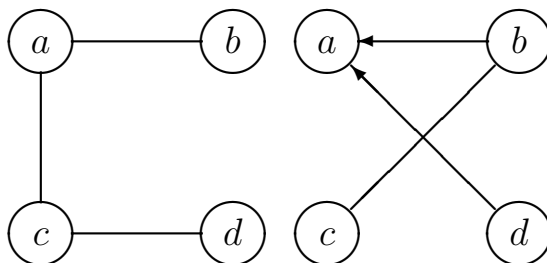

0.10.10.6 Differential imset (42)

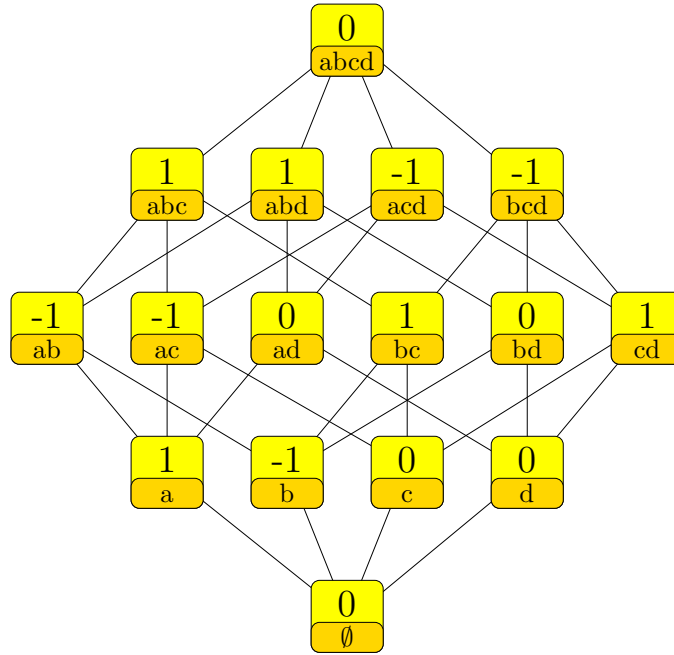

$$\begin{aligned}
 & \delta_{\{a\}} - \delta_{\{b\}} - \delta_{\{a,b\}} - \delta_{\{a,c\}} + \delta_{\{b,c\}} + \delta_{\{c,d\}} + \delta_{\{a,b,c\}} + \delta_{\{a,b,d\}} - \delta_{\{a,c,d\}} - \delta_{\{b,c,d\}} \\
 &= -u_{\langle a,c|\emptyset \rangle} + u_{\langle b,c|\emptyset \rangle} - u_{\langle c,d|ab \rangle} + u_{\langle a,b|cd \rangle} \\
 &= (\delta_{\emptyset} - \delta_{\{b\}} - \delta_{\{c\}} + \delta_{\{b,c\}} + \delta_{\{c,d\}} - \delta_{\{a,c,d\}} - \delta_{\{b,c,d\}} + \delta_{\{a,b,c,d\}}) \\
 &\quad - (\delta_{\emptyset} - \delta_{\{a\}} - \delta_{\{c\}} + \delta_{\{a,b\}} + \delta_{\{a,c\}} - \delta_{\{a,b,c\}} - \delta_{\{a,b,d\}} + \delta_{\{a,b,c,d\}})
 \end{aligned}$$

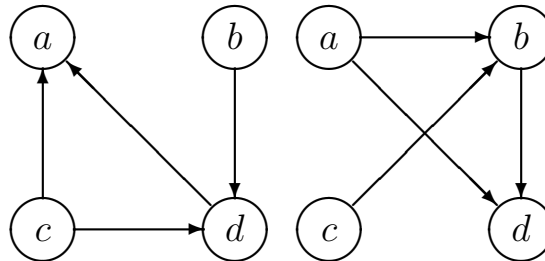

0.10.10.7 Differential imset (43)

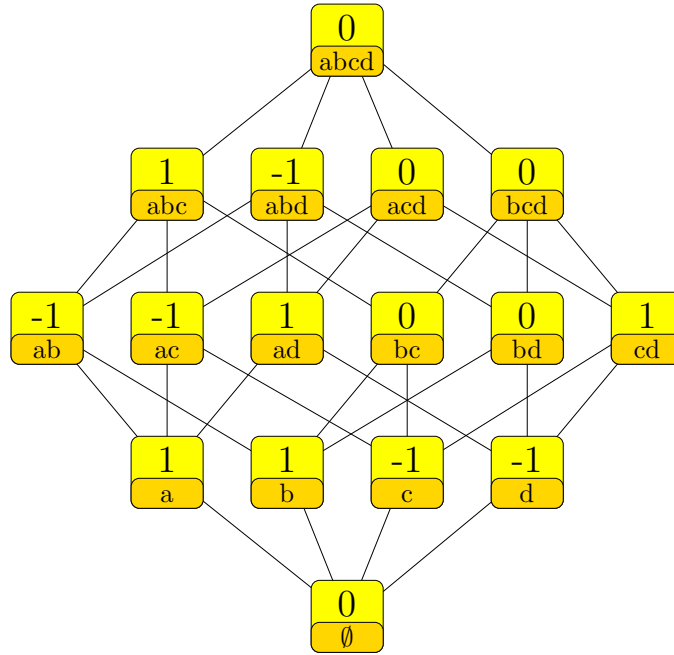

$$\begin{aligned}
 & \delta_{\{a\}} + \delta_{\{b\}} - \delta_{\{c\}} - \delta_{\{d\}} - \delta_{\{a,b\}} - \delta_{\{a,c\}} + \delta_{\{a,d\}} + \delta_{\{c,d\}} + \delta_{\{a,b,c\}} - \delta_{\{a,b,d\}} \\
 &= -u_{\langle a,b|\emptyset \rangle} + u_{\langle c,d|\emptyset \rangle} - u_{\langle b,d|ac \rangle} + u_{\langle b,c|ad \rangle} \\
 &= (\delta_{\emptyset} - \delta_{\{d\}} - \delta_{\{a,c\}} + \delta_{\{a,d\}} - \delta_{\{a,b,d\}} + \delta_{\{a,b,c,d\}}) \\
 &\quad - (\delta_{\emptyset} - \delta_{\{a\}} - \delta_{\{b\}} + \delta_{\{c\}} + \delta_{\{a,b\}} - \delta_{\{c,d\}} - \delta_{\{a,b,c\}} + \delta_{\{a,b,c,d\}}) \\
 &= (\delta_{\emptyset} - \delta_{\{c\}} - \delta_{\{d\}} + \delta_{\{a,d\}} + \delta_{\{c,d\}} - \delta_{\{a,b,d\}} - \delta_{\{a,c,d\}} + \delta_{\{a,b,c,d\}}) \\
 &\quad - (\delta_{\emptyset} - \delta_{\{a\}} - \delta_{\{b\}} + \delta_{\{a,b\}} + \delta_{\{a,c\}} - \delta_{\{a,b,c\}} - \delta_{\{a,c,d\}} + \delta_{\{a,b,c,d\}})
 \end{aligned}$$

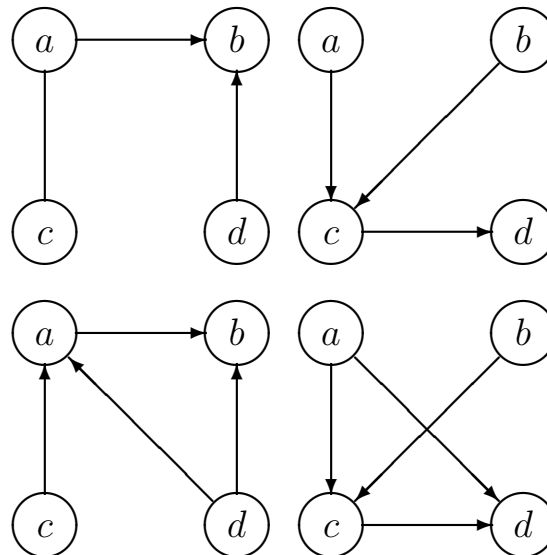

0.10.10.8 Differential imset (44)

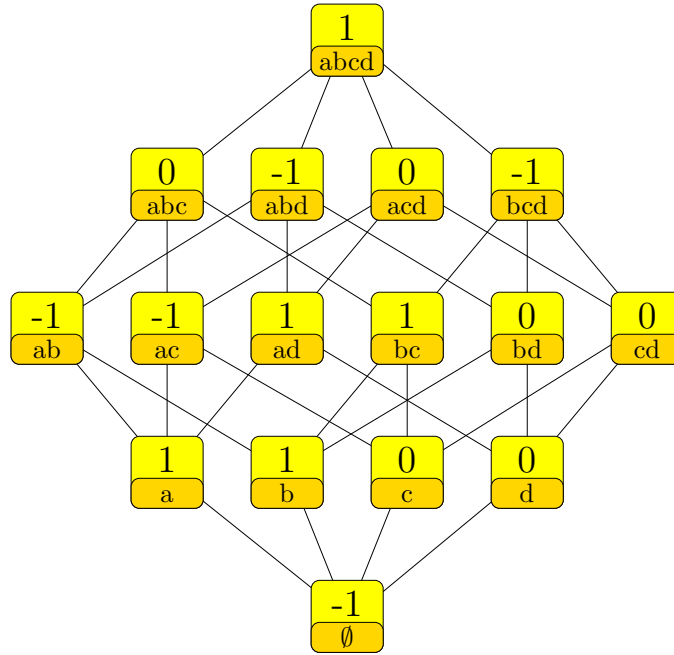

$$\begin{aligned}
 & -\delta_\emptyset + \delta_{\{a\}} + \delta_{\{b\}} - \delta_{\{a,b\}} - \delta_{\{a,c\}} + \delta_{\{a,d\}} + \delta_{\{b,c\}} - \delta_{\{a,b,d\}} - \delta_{\{b,c,d\}} + \delta_{\{a,b,c,d\}} \\
 &= -u_{\langle a,b|\emptyset \rangle} + u_{\langle a,d|bc \rangle} + u_{\langle b,c|a \rangle} - u_{\langle b,d|a \rangle} \\
 &= (\delta_{\{a\}} - \delta_{\{a,b\}} - \delta_{\{a,c\}} + \delta_{\{b,c\}} - \delta_{\{b,c,d\}} + \delta_{\{a,b,c,d\}}) \\
 &\quad - (\delta_\emptyset - \delta_{\{b\}} - \delta_{\{a,d\}} + \delta_{\{a,b,d\}})
 \end{aligned}$$

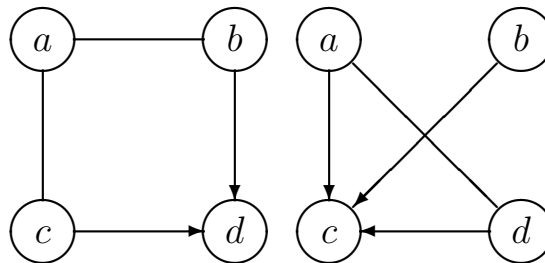

0.10.10.9 Differential imset (45)

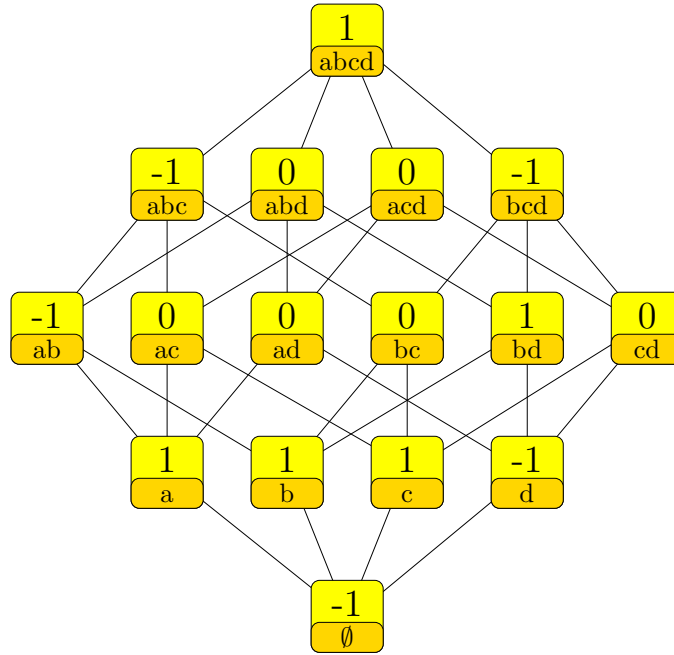

$$\begin{aligned}
 & -\delta_\emptyset + \delta_{\{a\}} + \delta_{\{b\}} + \delta_{\{c\}} - \delta_{\{d\}} - \delta_{\{a,b\}} + \delta_{\{b,d\}} - \delta_{\{a,b,c\}} - \delta_{\{b,c,d\}} + \delta_{\{a,b,c,d\}} \\
 &= -u_{\langle a,b|\emptyset \rangle} - u_{\langle b,c|\emptyset \rangle} + u_{\langle b,d|\emptyset \rangle} + u_{\langle a,d|bc \rangle} \\
 &= (\delta_\emptyset - \delta_{\{d\}} - \delta_{\{a,b\}} + \delta_{\{b,d\}} - \delta_{\{b,c,d\}} + \delta_{\{a,b,c,d\}}) \\
 &\quad - (+2\delta_\emptyset - \delta_{\{a\}} - \delta_{\{b\}} - \delta_{\{c\}} + \delta_{\{a,b,c\}})
 \end{aligned}$$

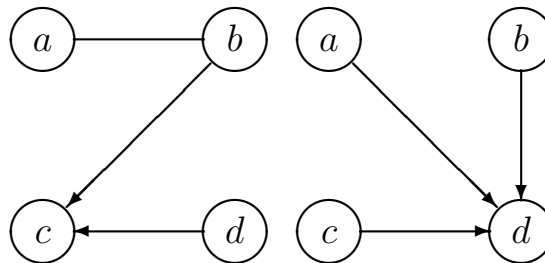



## 0.12 Squared Euclidean length 12

### 0.12.6 Number of nonzero values 6

#### 0.12.6.1 Differential imset (46)

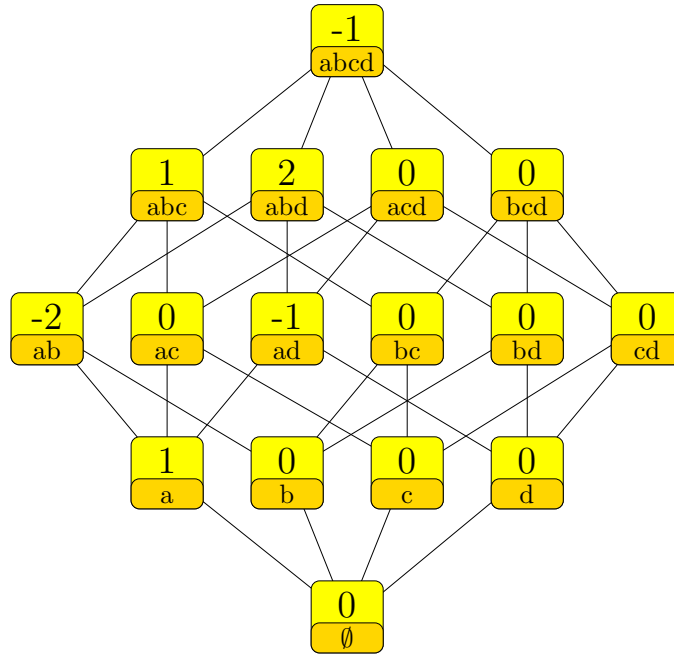

$$\begin{aligned}
 & \delta_{\{a\}} - 2\delta_{\{a,b\}} - \delta_{\{a,d\}} + \delta_{\{a,b,c\}} + 2\delta_{\{a,b,d\}} - \delta_{\{a,b,c,d\}} \\
 &= -u_{\langle c,d|ab \rangle} + u_{\langle b,d|a \rangle} \\
 &= (\delta_{\emptyset} - \delta_{\{d\}} - \delta_{\{a,b\}} + \delta_{\{a,b,d\}}) \\
 &\quad - (\delta_{\emptyset} - \delta_{\{a\}} - \delta_{\{d\}} + \delta_{\{a,b\}} + \delta_{\{a,d\}} - \delta_{\{a,b,c\}} - \delta_{\{a,b,d\}} + \delta_{\{a,b,c,d\}}) \\
 &= (\delta_{\emptyset} - \delta_{\{b\}} - \delta_{\{a,d\}} + \delta_{\{a,b,d\}}) \\
 &\quad - (\delta_{\emptyset} - \delta_{\{a\}} - \delta_{\{b\}} + 2\delta_{\{a,b\}} - \delta_{\{a,b,c\}} - \delta_{\{a,b,d\}} + \delta_{\{a,b,c,d\}}) \\
 &= (\delta_{\{a\}} - \delta_{\{a,b\}} - \delta_{\{a,d\}} + \delta_{\{a,b,d\}}) \\
 &\quad - (\delta_{\{a,b\}} - \delta_{\{a,b,c\}} - \delta_{\{a,b,d\}} + \delta_{\{a,b,c,d\}})
 \end{aligned}$$

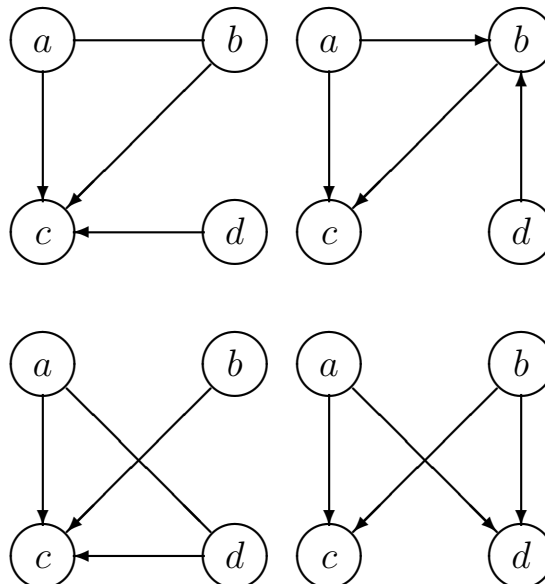

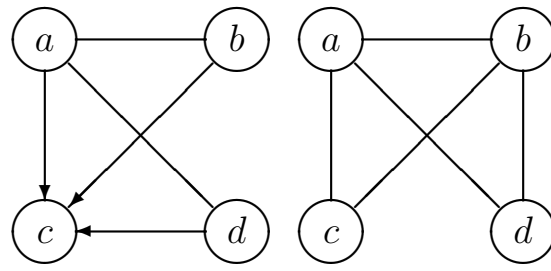

0.12.6.2 Differential imset (47)

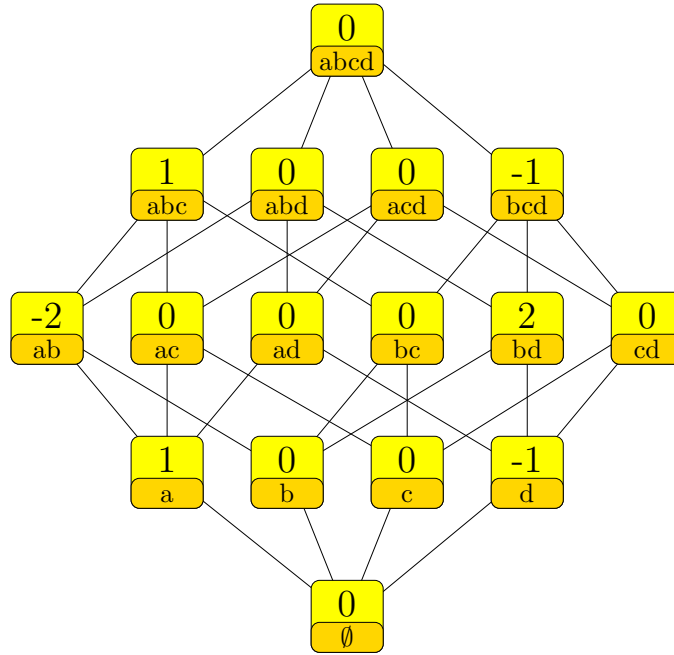

$$\begin{aligned}
 & \delta_{\{a\}} - \delta_{\{d\}} - 2\delta_{\{a,b\}} + 2\delta_{\{b,d\}} + \delta_{\{a,b,c\}} - \delta_{\{b,c,d\}} \\
 &= -u_{\langle c,d|ab \rangle} + u_{\langle a,c|bd \rangle} + u_{\langle b,d|a \rangle} - u_{\langle a,b|d \rangle} \\
 &= (\delta_{\{a\}} - \delta_{\{a,b\}} - \delta_{\{a,d\}} + \delta_{\{b,d\}} - \delta_{\{b,c,d\}} + \delta_{\{a,b,c,d\}}) \\
 &\quad - (\delta_{\{d\}} + \delta_{\{a,b\}} - \delta_{\{a,d\}} - \delta_{\{b,d\}} - \delta_{\{a,b,c\}} + \delta_{\{a,b,c,d\}})
 \end{aligned}$$

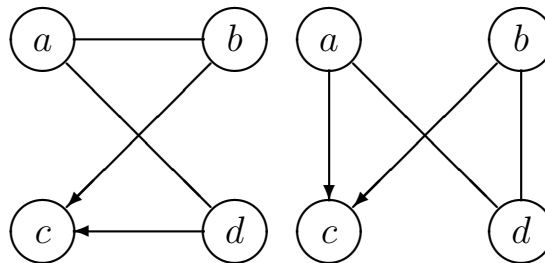

0.12.6.3 Differential imset (48)

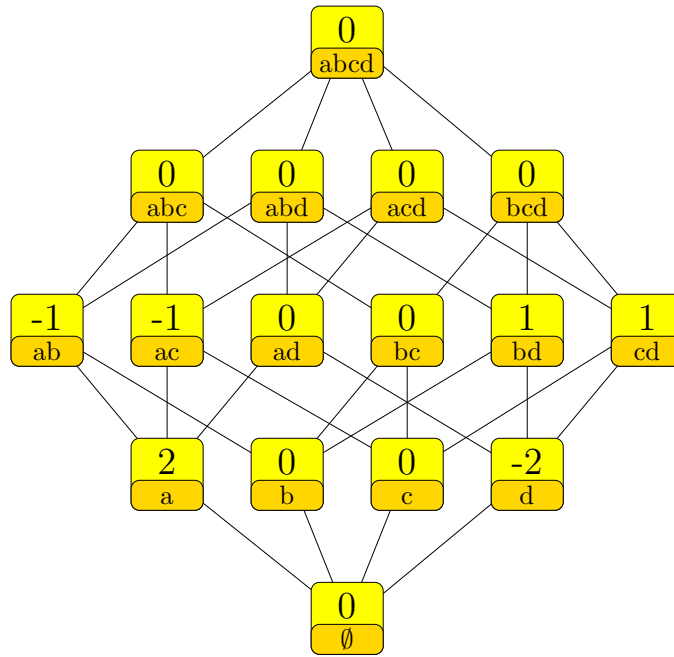

$$\begin{aligned}
 &+2\delta_{\{a\}} - 2\delta_{\{d\}} - \delta_{\{a,b\}} - \delta_{\{a,c\}} + \delta_{\{b,d\}} + \delta_{\{c,d\}} \\
 &= -u_{\langle a,b|\emptyset \rangle} - u_{\langle a,c|\emptyset \rangle} + u_{\langle b,d|\emptyset \rangle} + u_{\langle c,d|\emptyset \rangle} \\
 &= (\delta_{\emptyset} + \delta_{\{a\}} - \delta_{\{c\}} - \delta_{\{d\}} - \delta_{\{a,b\}} + \delta_{\{c,d\}} - \delta_{\{a,c,d\}} + \delta_{\{a,b,c,d\}}) \\
 &\quad - (\delta_{\emptyset} - \delta_{\{a\}} - \delta_{\{c\}} + \delta_{\{d\}} + \delta_{\{a,c\}} - \delta_{\{b,d\}} - \delta_{\{a,c,d\}} + \delta_{\{a,b,c,d\}}) \\
 &= (\delta_{\emptyset} + \delta_{\{a\}} - \delta_{\{b\}} - \delta_{\{d\}} - \delta_{\{a,c\}} + \delta_{\{b,d\}} - \delta_{\{a,b,d\}} + \delta_{\{a,b,c,d\}}) \\
 &\quad - (\delta_{\emptyset} - \delta_{\{a\}} - \delta_{\{b\}} + \delta_{\{d\}} + \delta_{\{a,b\}} - \delta_{\{c,d\}} - \delta_{\{a,b,d\}} + \delta_{\{a,b,c,d\}})
 \end{aligned}$$

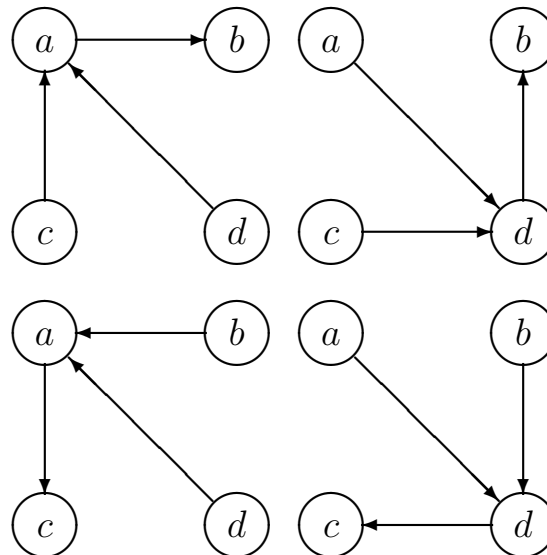

0.12.6.4 Differential imset (49)

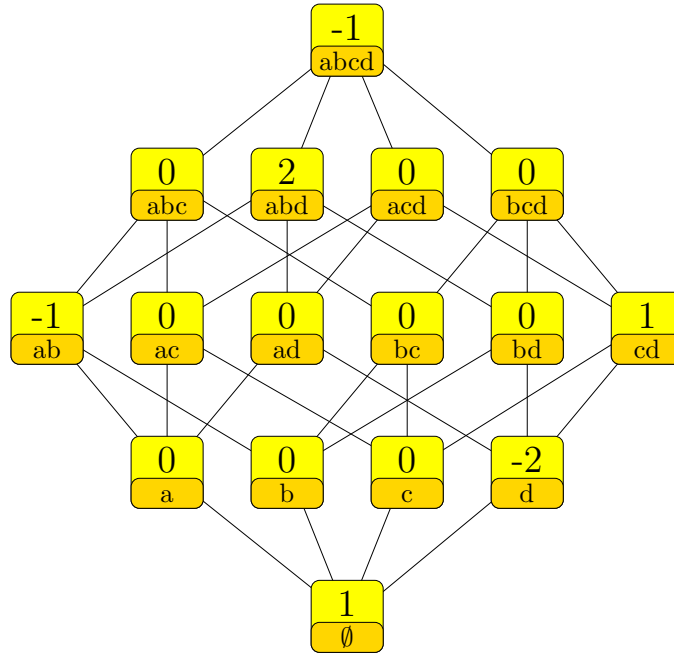

$$\begin{aligned}
 & \delta_\emptyset - 2\delta_{\{d\}} - \delta_{\{a,b\}} + \delta_{\{c,d\}} + 2\delta_{\{a,b,d\}} - \delta_{\{a,b,c,d\}} \\
 &= u_{\langle a,d|\emptyset \rangle} - u_{\langle b,c|ad \rangle} + u_{\langle b,d|a \rangle} - u_{\langle a,c|d \rangle} \\
 &= (+2\delta_\emptyset - \delta_{\{a\}} - \delta_{\{b\}} - \delta_{\{d\}} + \delta_{\{a,b,d\}}) \\
 &\quad - (\delta_\emptyset - \delta_{\{a\}} - \delta_{\{b\}} + \delta_{\{d\}} + \delta_{\{a,b\}} - \delta_{\{c,d\}} - \delta_{\{a,b,d\}} + \delta_{\{a,b,c,d\}})
 \end{aligned}$$

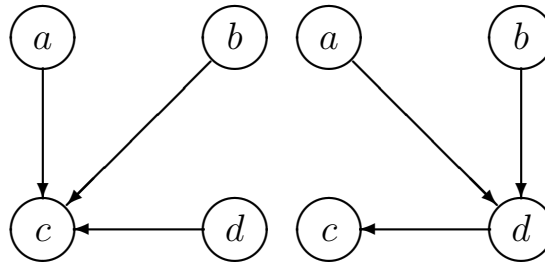

0.12.6.5 Differential imset (50)

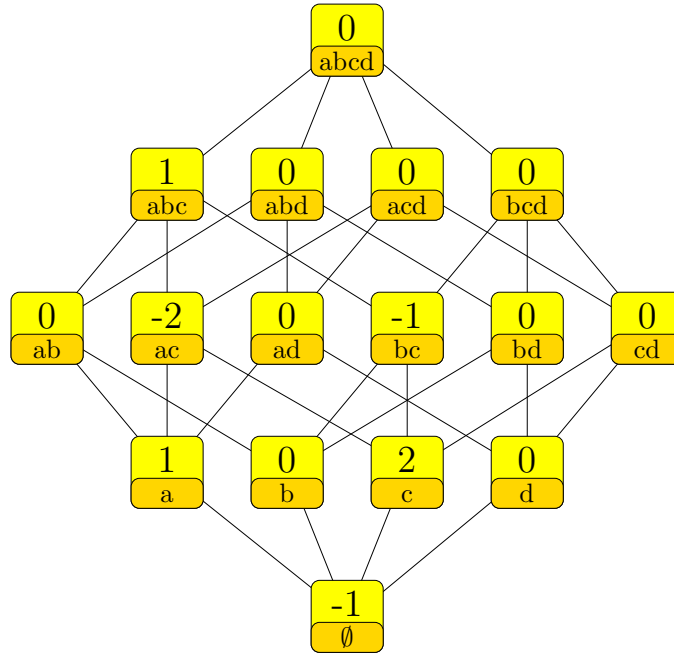

$$\begin{aligned}
 & -\delta_\emptyset + \delta_{\{a\}} + 2\delta_{\{c\}} - 2\delta_{\{a,c\}} - \delta_{\{b,c\}} + \delta_{\{a,b,c\}} \\
 &= -u_{\langle a,c|\emptyset \rangle} + u_{\langle a,b|c \rangle} \\
 &= (\delta_\emptyset + \delta_{\{c\}} - \delta_{\{d\}} - \delta_{\{a,c\}} - \delta_{\{b,c\}} + \delta_{\{a,b,c,d\}}) \\
 &\quad - (+2\delta_\emptyset - \delta_{\{a\}} - \delta_{\{c\}} - \delta_{\{d\}} + \delta_{\{a,c\}} - \delta_{\{a,b,c\}} + \delta_{\{a,b,c,d\}}) \\
 &= (\delta_{\{c\}} - \delta_{\{b,c\}} - \delta_{\{a,c,d\}} + \delta_{\{a,b,c,d\}}) \\
 &\quad - (\delta_\emptyset - \delta_{\{a\}} - \delta_{\{c\}} + 2\delta_{\{a,c\}} - \delta_{\{a,b,c\}} - \delta_{\{a,c,d\}} + \delta_{\{a,b,c,d\}})
 \end{aligned}$$

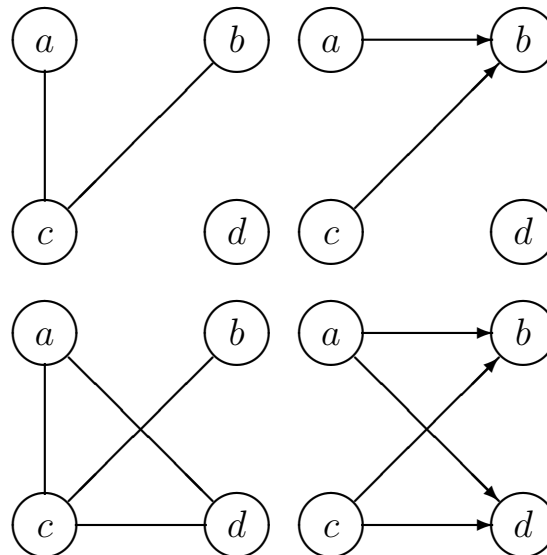

0.12.9 Number of nonzero values 9

0.12.9.1 Differential imset (51)

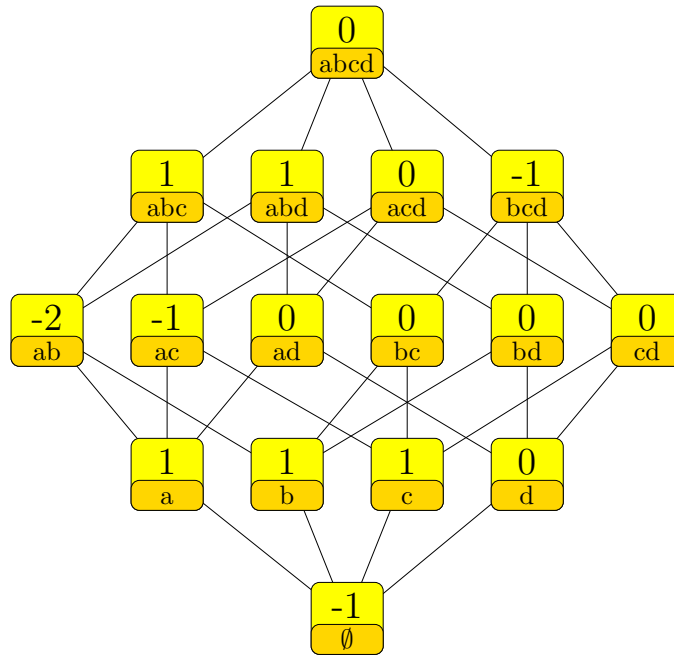

$$\begin{aligned}
 & -\delta_{\emptyset} + \delta_{\{a\}} + \delta_{\{b\}} + \delta_{\{c\}} - 2\delta_{\{a,b\}} - \delta_{\{a,c\}} + \delta_{\{a,b,c\}} + \delta_{\{a,b,d\}} - \delta_{\{b,c,d\}} \\
 &= -u_{\langle a,c|\emptyset \rangle} - u_{\langle c,d|ab \rangle} + u_{\langle a,d|bc \rangle} + u_{\langle a,c|b \rangle} \\
 &= (\delta_{\{b\}} - \delta_{\{a,b\}} - \delta_{\{b,c,d\}} + \delta_{\{a,b,c,d\}}) \\
 &\quad - (\delta_{\emptyset} - \delta_{\{a\}} - \delta_{\{c\}} + \delta_{\{a,b\}} + \delta_{\{a,c\}} - \delta_{\{a,b,c\}} - \delta_{\{a,b,d\}} + \delta_{\{a,b,c,d\}}) \\
 &= (\delta_{\{c\}} - \delta_{\{a,c\}} - \delta_{\{b,c,d\}} + \delta_{\{a,b,c,d\}}) \\
 &\quad - (\delta_{\emptyset} - \delta_{\{a\}} - \delta_{\{b\}} + 2\delta_{\{a,b\}} - \delta_{\{a,b,c\}} - \delta_{\{a,b,d\}} + \delta_{\{a,b,c,d\}})
 \end{aligned}$$

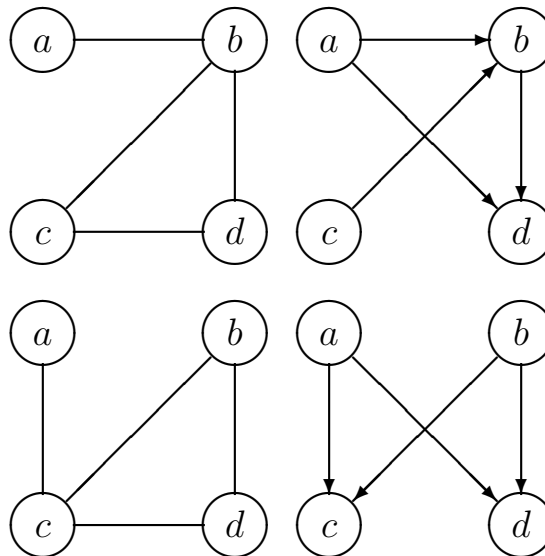

0.12.9.2 Differential imset (52)

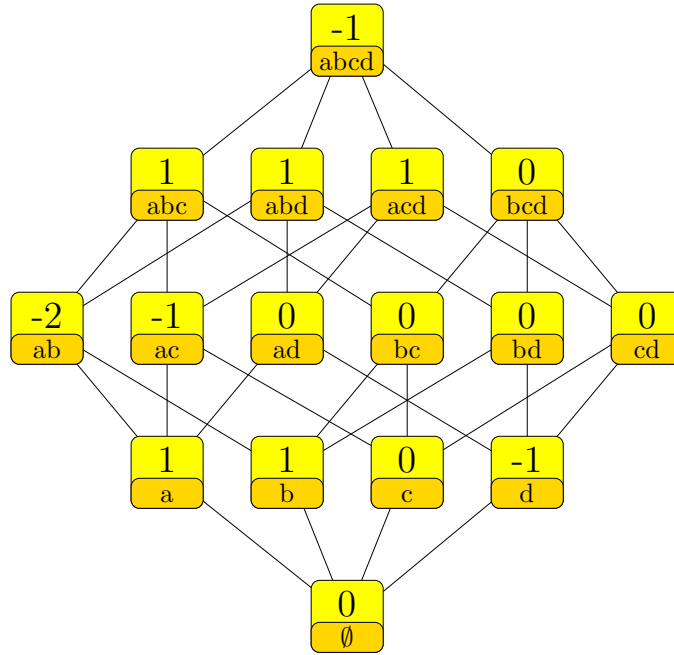

$$\begin{aligned}
 & \delta_{\{a\}} + \delta_{\{b\}} - \delta_{\{d\}} - 2\delta_{\{a,b\}} - \delta_{\{a,c\}} + \delta_{\{a,b,c\}} + \delta_{\{a,b,d\}} + \delta_{\{a,c,d\}} - \delta_{\{a,b,c,d\}} \\
 &= -u_{\langle a,b|\emptyset \rangle} + u_{\langle a,d|\emptyset \rangle} - u_{\langle b,d|ac \rangle} + u_{\langle b,d|a \rangle} \\
 &= (\delta_{\emptyset} - \delta_{\{d\}} - \delta_{\{a,b\}} + \delta_{\{a,b,d\}}) \\
 &\quad - (\delta_{\emptyset} - \delta_{\{a\}} - \delta_{\{b\}} + \delta_{\{a,b\}} + \delta_{\{a,c\}} - \delta_{\{a,b,c\}} - \delta_{\{a,c,d\}} + \delta_{\{a,b,c,d\}}) \\
 &= (\delta_{\emptyset} - \delta_{\{d\}} - \delta_{\{a,c\}} + \delta_{\{a,c,d\}}) \\
 &\quad - (\delta_{\emptyset} - \delta_{\{a\}} - \delta_{\{b\}} + 2\delta_{\{a,b\}} - \delta_{\{a,b,c\}} - \delta_{\{a,b,d\}} + \delta_{\{a,b,c,d\}})
 \end{aligned}$$

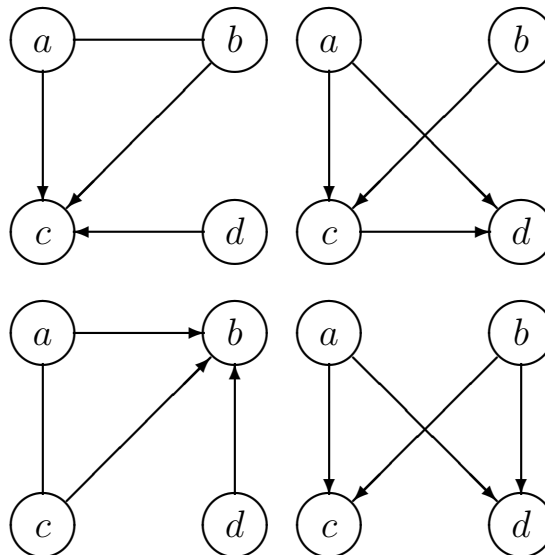



0.12.9.3 Differential imset (53)

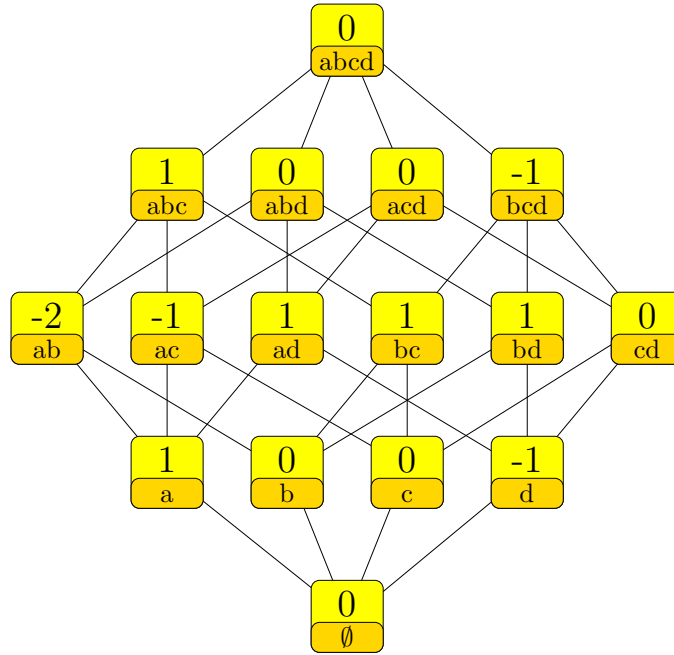

$$\begin{aligned}
 & \delta_{\{a\}} - \delta_{\{d\}} - 2\delta_{\{a,b\}} - \delta_{\{a,c\}} + \delta_{\{a,d\}} + \delta_{\{b,c\}} + \delta_{\{b,d\}} + \delta_{\{a,b,c\}} - \delta_{\{b,c,d\}} \\
 &= -u_{\langle c,d|ab \rangle} + u_{\langle a,d|bc \rangle} + u_{\langle b,c|a \rangle} - u_{\langle a,b|d \rangle} \\
 &= (\delta_{\{a\}} - \delta_{\{a,b\}} - \delta_{\{a,c\}} + \delta_{\{b,c\}} - \delta_{\{b,c,d\}} + \delta_{\{a,b,c,d\}}) \\
 &\quad - (\delta_{\{d\}} + \delta_{\{a,b\}} - \delta_{\{a,d\}} - \delta_{\{b,d\}} - \delta_{\{a,b,c\}} + \delta_{\{a,b,c,d\}})
 \end{aligned}$$

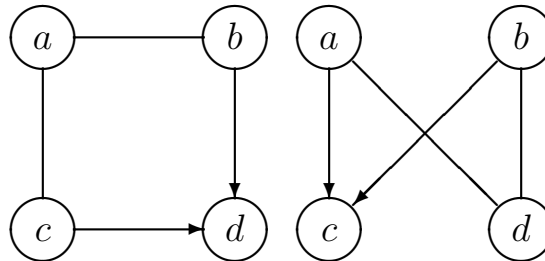

0.12.9.4 Differential imset (54)

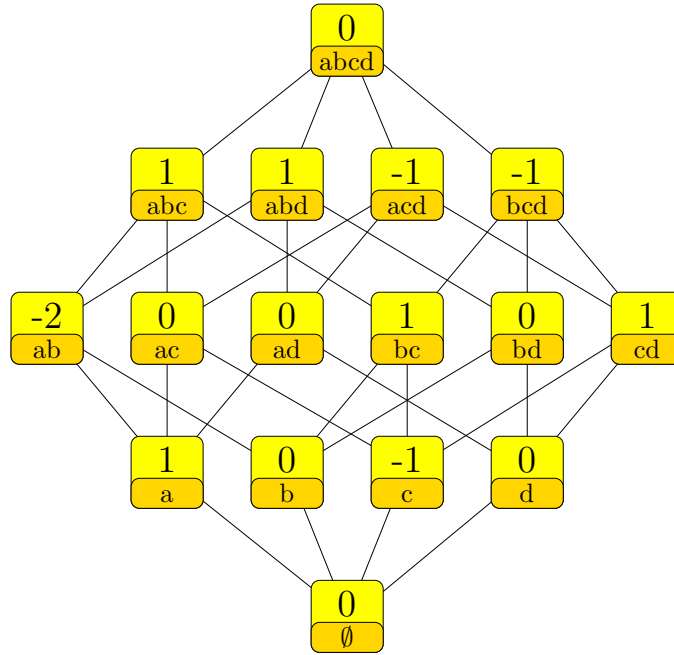

$$\begin{aligned}
 & \delta_{\{a\}} - \delta_{\{c\}} - 2\delta_{\{a,b\}} + \delta_{\{b,c\}} + \delta_{\{c,d\}} + \delta_{\{a,b,c\}} + \delta_{\{a,b,d\}} - \delta_{\{a,c,d\}} - \delta_{\{b,c,d\}} \\
 &= -u_{\langle a,b|\emptyset \rangle} + u_{\langle b,c|\emptyset \rangle} - u_{\langle c,d|ab \rangle} + u_{\langle a,b|cd \rangle} \\
 &= (\delta_{\emptyset} - \delta_{\{b\}} - \delta_{\{c\}} + \delta_{\{b,c\}} + \delta_{\{c,d\}} - \delta_{\{a,c,d\}} - \delta_{\{b,c,d\}} + \delta_{\{a,b,c,d\}}) \\
 &\quad - (\delta_{\emptyset} - \delta_{\{a\}} - \delta_{\{b\}} + 2\delta_{\{a,b\}} - \delta_{\{a,b,c\}} - \delta_{\{a,b,d\}} + \delta_{\{a,b,c,d\}})
 \end{aligned}$$

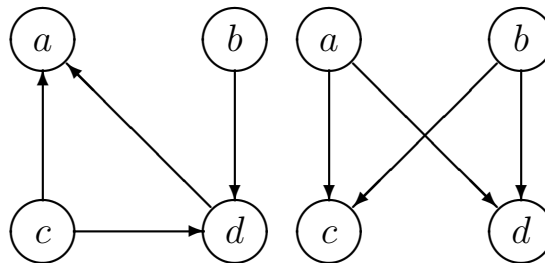

0.12.9.5 Differential imset (55)

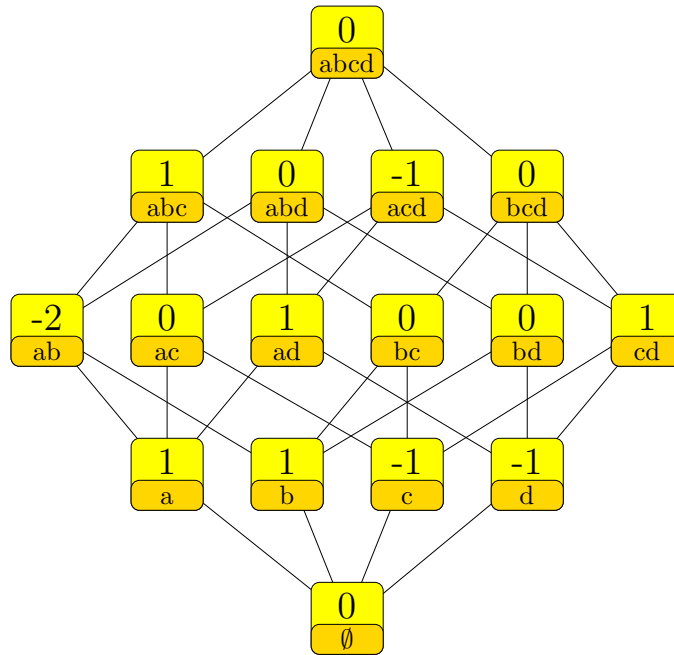

$$\begin{aligned}
 & \delta_{\{a\}} + \delta_{\{b\}} - \delta_{\{c\}} - \delta_{\{d\}} - 2\delta_{\{a,b\}} + \delta_{\{a,d\}} + \delta_{\{c,d\}} + \delta_{\{a,b,c\}} - \delta_{\{a,c,d\}} \\
 &= -u_{\langle a,b|\emptyset \rangle} + u_{\langle a,d|\emptyset \rangle} + u_{\langle b,c|a \rangle} - u_{\langle a,d|c \rangle} \\
 &= (\delta_{\emptyset} - \delta_{\{d\}} - \delta_{\{a,b\}} + \delta_{\{a,d\}} - \delta_{\{a,c,d\}} + \delta_{\{a,b,c,d\}}) \\
 &\quad - (\delta_{\emptyset} - \delta_{\{a\}} - \delta_{\{b\}} + \delta_{\{c\}} + \delta_{\{a,b\}} - \delta_{\{c,d\}} - \delta_{\{a,b,c\}} + \delta_{\{a,b,c,d\}})
 \end{aligned}$$

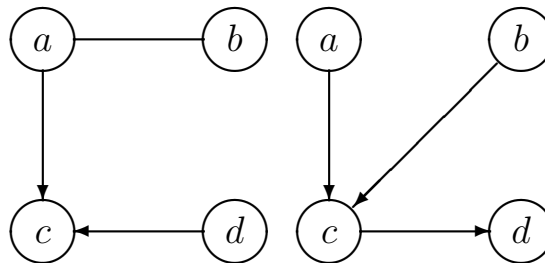

0.12.9.6 Differential imset (56)

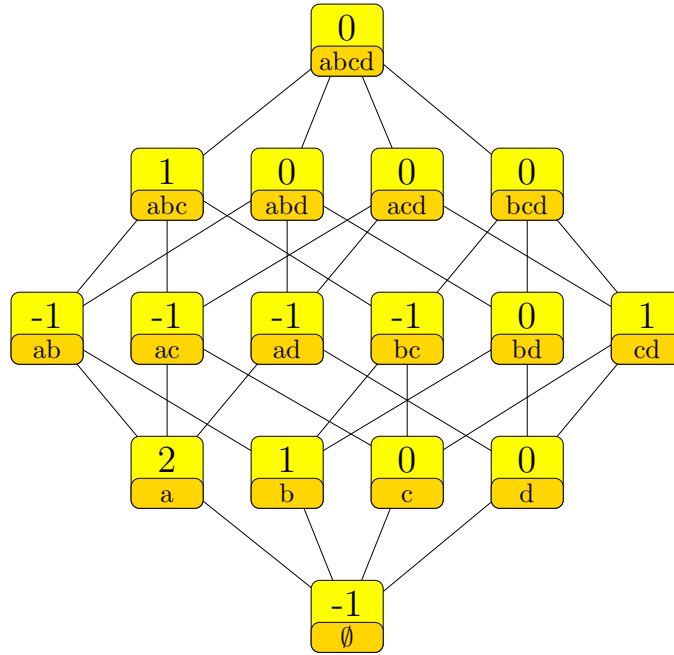

$$\begin{aligned}
 & -\delta_{\emptyset} + 2\delta_{\{a\}} + \delta_{\{b\}} - \delta_{\{a,b\}} - \delta_{\{a,c\}} - \delta_{\{a,d\}} - \delta_{\{b,c\}} + \delta_{\{c,d\}} + \delta_{\{a,b,c\}} \\
 &= -u_{\langle a,c|\emptyset \rangle} - u_{\langle a,d|\emptyset \rangle} + u_{\langle c,d|\emptyset \rangle} + u_{\langle a,c|b \rangle} \\
 &= (\delta_{\{a\}} + \delta_{\{b\}} - \delta_{\{a,b\}} - \delta_{\{a,d\}} - \delta_{\{b,c\}} + \delta_{\{a,b,c,d\}}) \\
 &\quad - (\delta_{\emptyset} - \delta_{\{a\}} + \delta_{\{a,c\}} - \delta_{\{c,d\}} - \delta_{\{a,b,c\}} + \delta_{\{a,b,c,d\}}) \\
 &= (\delta_{\{a\}} + \delta_{\{c\}} - \delta_{\{a,c\}} - \delta_{\{a,d\}} - \delta_{\{b,c\}} + \delta_{\{a,b,c,d\}}) \\
 &\quad - (\delta_{\emptyset} - \delta_{\{a\}} - \delta_{\{b\}} + \delta_{\{c\}} + \delta_{\{a,b\}} - \delta_{\{c,d\}} - \delta_{\{a,b,c\}} + \delta_{\{a,b,c,d\}}) \\
 &= (\delta_{\{a\}} - \delta_{\{a,c\}} - \delta_{\{a,d\}} + \delta_{\{c,d\}} - \delta_{\{b,c,d\}} + \delta_{\{a,b,c,d\}}) \\
 &\quad - (\delta_{\emptyset} - \delta_{\{a\}} - \delta_{\{b\}} + \delta_{\{a,b\}} + \delta_{\{b,c\}} - \delta_{\{a,b,c\}} - \delta_{\{b,c,d\}} + \delta_{\{a,b,c,d\}})
 \end{aligned}$$

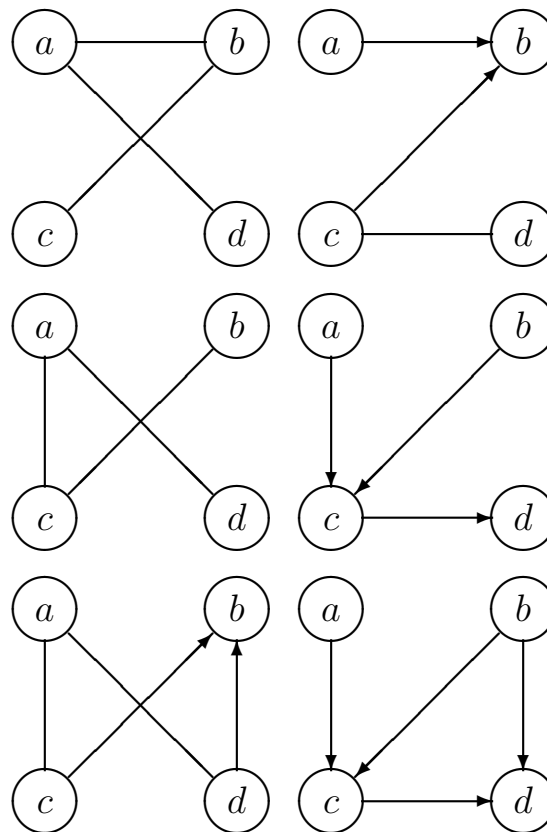

0.12.9.7 Differential imset (57)

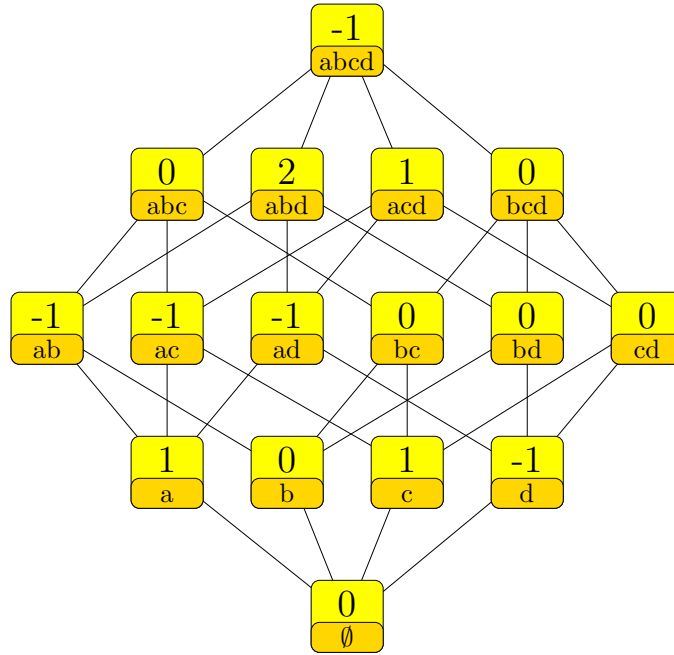

$$\begin{aligned}
 & \delta_{\{a\}} + \delta_{\{c\}} - \delta_{\{d\}} - \delta_{\{a,b\}} - \delta_{\{a,c\}} - \delta_{\{a,d\}} + 2\delta_{\{a,b,d\}} + \delta_{\{a,c,d\}} - \delta_{\{a,b,c,d\}} \\
 &= -u_{\langle a,c|\emptyset \rangle} + u_{\langle a,d|\emptyset \rangle} - u_{\langle b,c|ad \rangle} + u_{\langle b,d|a \rangle} \\
 &= (\delta_{\emptyset} - \delta_{\{d\}} - \delta_{\{a,b\}} + \delta_{\{a,b,d\}}) \\
 &\quad - (\delta_{\emptyset} - \delta_{\{a\}} - \delta_{\{c\}} + \delta_{\{a,c\}} + \delta_{\{a,d\}} - \delta_{\{a,b,d\}} - \delta_{\{a,c,d\}} + \delta_{\{a,b,c,d\}})
 \end{aligned}$$

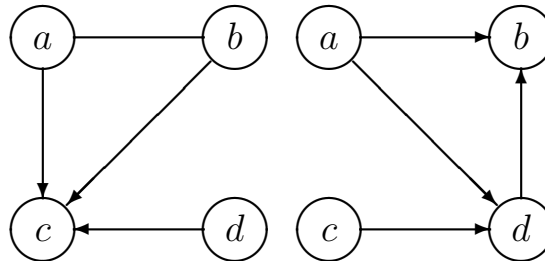

0.12.9.8 Differential imset (58)

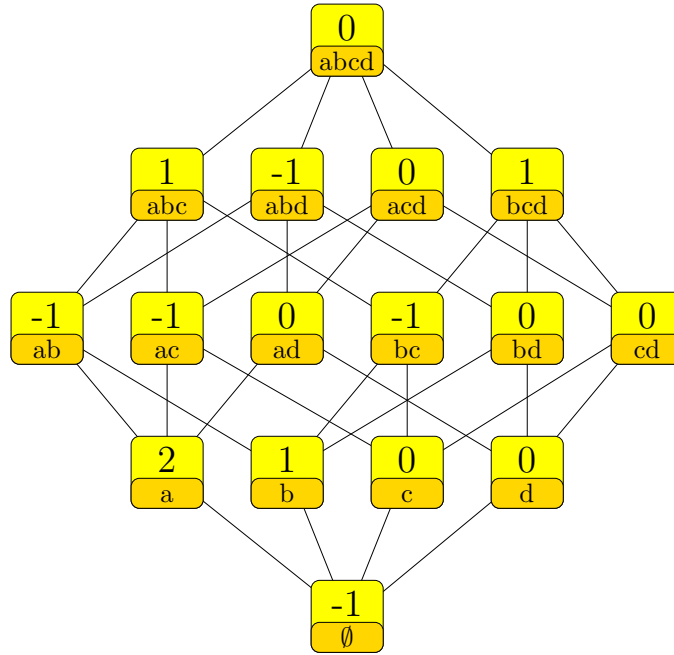

$$\begin{aligned}
 & -\delta_\emptyset + 2\delta_{\{a\}} + \delta_{\{b\}} - \delta_{\{a,b\}} - \delta_{\{a,c\}} - \delta_{\{b,c\}} + \delta_{\{a,b,c\}} - \delta_{\{a,b,d\}} + \delta_{\{b,c,d\}} \\
 & = -u_{\langle a,b|\emptyset \rangle} + u_{\langle c,d|ab \rangle} - u_{\langle a,d|bc \rangle} + u_{\langle b,c|a \rangle} \\
 & = (\delta_{\{a\}} - \delta_{\{a,c\}} - \delta_{\{a,b,d\}} + \delta_{\{a,b,c,d\}}) \\
 & \quad - (\delta_\emptyset - \delta_{\{a\}} - \delta_{\{b\}} + \delta_{\{a,b\}} + \delta_{\{b,c\}} - \delta_{\{a,b,c\}} - \delta_{\{b,c,d\}} + \delta_{\{a,b,c,d\}})
 \end{aligned}$$

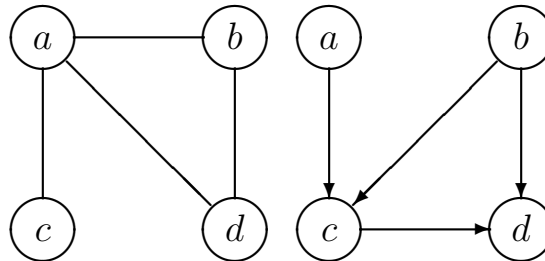

0.12.9.9 Differential imset (59)

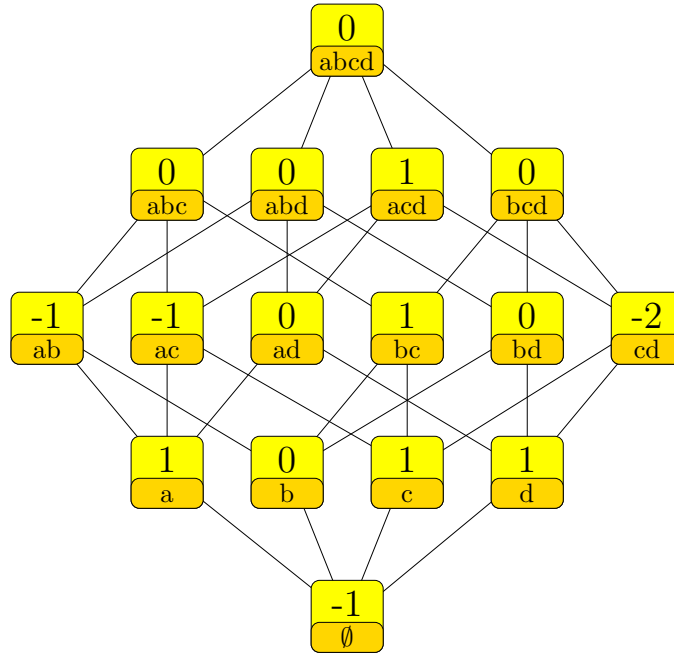

$$\begin{aligned}
 & -\delta_{\emptyset} + \delta_{\{a\}} + \delta_{\{c\}} + \delta_{\{d\}} - \delta_{\{a,b\}} - \delta_{\{a,c\}} + \delta_{\{b,c\}} - 2\delta_{\{c,d\}} + \delta_{\{a,c,d\}} \\
 & = -u_{\langle a,b|\emptyset \rangle} + u_{\langle b,c|\emptyset \rangle} - u_{\langle c,d|\emptyset \rangle} + u_{\langle a,d|c \rangle} \\
 & = (\delta_{\{a\}} + \delta_{\{c\}} - \delta_{\{a,b\}} - \delta_{\{a,c\}} - \delta_{\{c,d\}} + \delta_{\{a,b,c,d\}}) \\
 & \quad - (\delta_{\emptyset} - \delta_{\{d\}} - \delta_{\{b,c\}} + \delta_{\{c,d\}} - \delta_{\{a,c,d\}} + \delta_{\{a,b,c,d\}})
 \end{aligned}$$

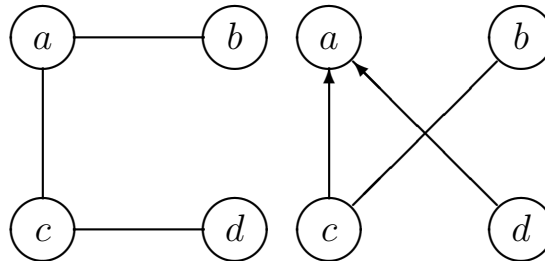

0.12.9.10 Differential imset (60)

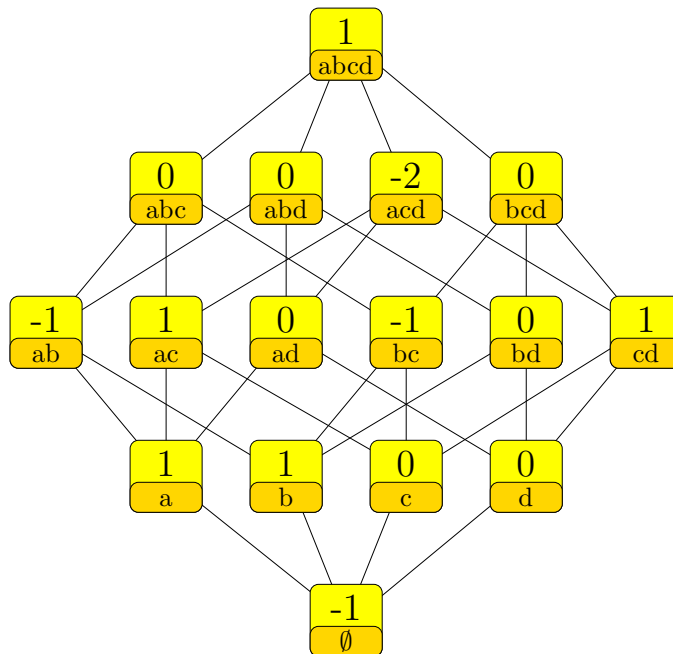

$$\begin{aligned}
 & -\delta_{\emptyset} + \delta_{\{a\}} + \delta_{\{b\}} - \delta_{\{a,b\}} + \delta_{\{a,c\}} - \delta_{\{b,c\}} + \delta_{\{c,d\}} - 2\delta_{\{a,c,d\}} + \delta_{\{a,b,c,d\}} \\
 &= -u_{\langle a,c|\emptyset \rangle} + u_{\langle b,d|ac \rangle} + u_{\langle a,c|b \rangle} - u_{\langle a,d|c \rangle} \\
 &= (\delta_{\{b\}} - \delta_{\{a,b\}} + \delta_{\{a,c\}} - \delta_{\{b,c\}} - \delta_{\{a,c,d\}} + \delta_{\{a,b,c,d\}}) \\
 &\quad - (\delta_{\emptyset} - \delta_{\{a\}} - \delta_{\{c,d\}} + \delta_{\{a,c,d\}})
 \end{aligned}$$

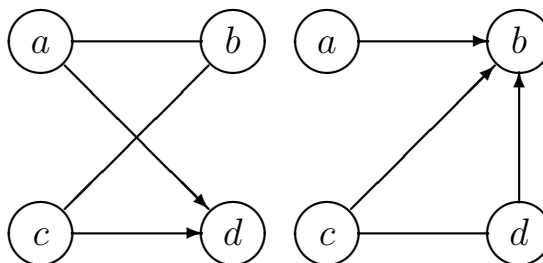



0.12.9.11 Differential imset (61)

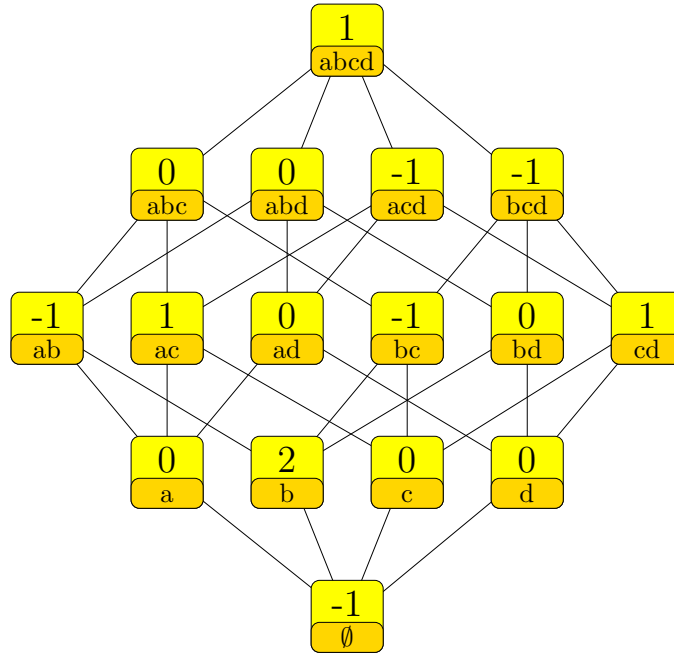

$$\begin{aligned}
 & -\delta_{\emptyset} + 2\delta_{\{b\}} - \delta_{\{a,b\}} + \delta_{\{a,c\}} - \delta_{\{b,c\}} + \delta_{\{c,d\}} - \delta_{\{a,c,d\}} - \delta_{\{b,c,d\}} + \delta_{\{a,b,c,d\}} \\
 &= -u_{\langle b,c|\emptyset \rangle} + u_{\langle b,d|ac \rangle} + u_{\langle a,c|b \rangle} - u_{\langle b,d|c \rangle} \\
 &= (\delta_{\{b\}} - \delta_{\{a,b\}} + \delta_{\{a,c\}} - \delta_{\{b,c\}} - \delta_{\{a,c,d\}} + \delta_{\{a,b,c,d\}}) \\
 &\quad - (\delta_{\emptyset} - \delta_{\{b\}} - \delta_{\{c,d\}} + \delta_{\{b,c,d\}})
 \end{aligned}$$

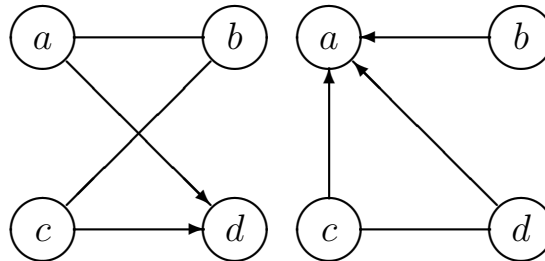

0.12.9.12 Differential imset (62)

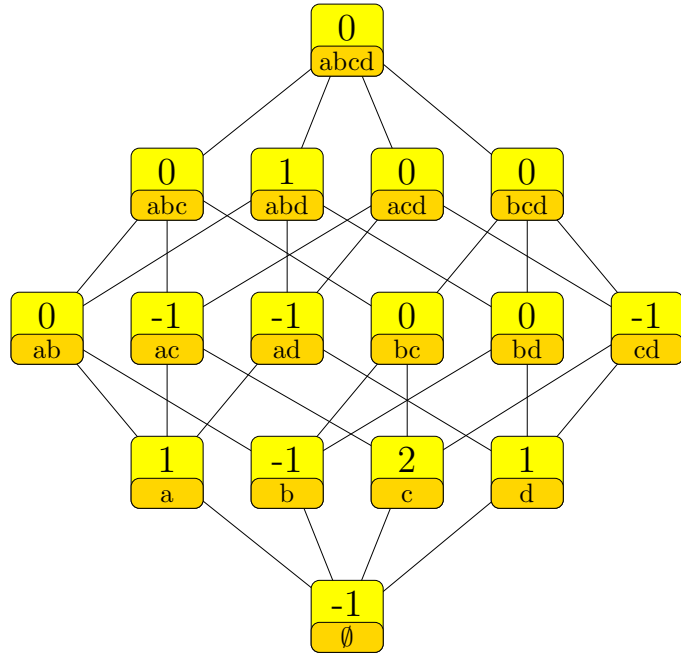

$$\begin{aligned}
 & -\delta_{\emptyset} + \delta_{\{a\}} - \delta_{\{b\}} + 2\delta_{\{c\}} + \delta_{\{d\}} - \delta_{\{a,c\}} - \delta_{\{a,d\}} - \delta_{\{c,d\}} + \delta_{\{a,b,d\}} \\
 &= u_{\langle a,b|\emptyset \rangle} - u_{\langle a,c|\emptyset \rangle} - u_{\langle c,d|\emptyset \rangle} + u_{\langle b,d|a \rangle} \\
 &= (\delta_{\emptyset} - \delta_{\{b\}} + \delta_{\{c\}} - \delta_{\{a,c\}} - \delta_{\{c,d\}} + \delta_{\{a,b,c,d\}}) \\
 &\quad - (+2\delta_{\emptyset} - \delta_{\{a\}} - \delta_{\{c\}} - \delta_{\{d\}} + \delta_{\{a,d\}} - \delta_{\{a,b,d\}} + \delta_{\{a,b,c,d\}})
 \end{aligned}$$

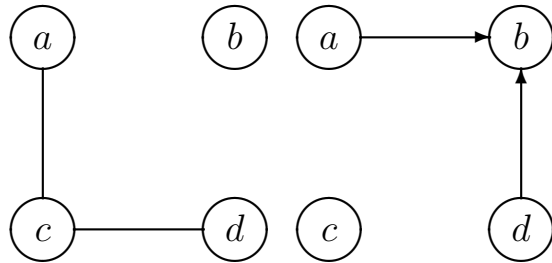

0.12.12 Number of nonzero values 12

0.12.12.1 Differential imset (63)

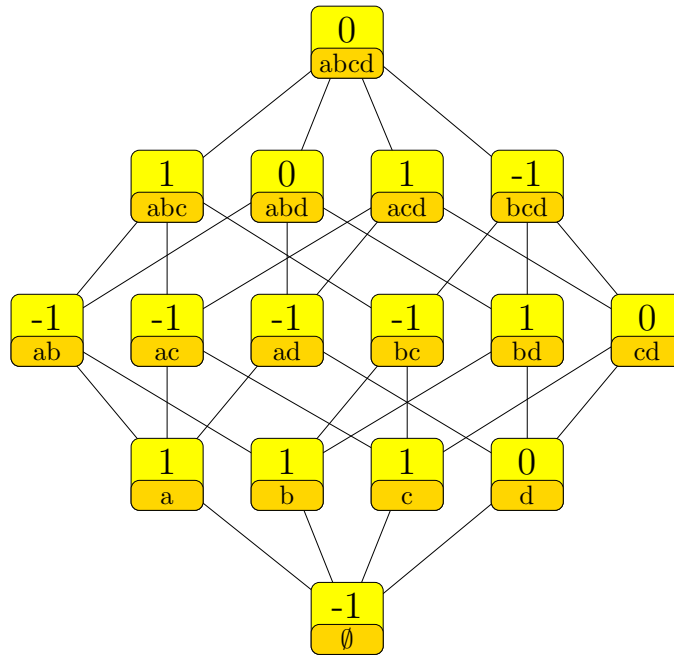

$$\begin{aligned}
 & -\delta_{\emptyset} + \delta_{\{a\}} + \delta_{\{b\}} + \delta_{\{c\}} - \delta_{\{a,b\}} - \delta_{\{a,c\}} - \delta_{\{a,d\}} - \delta_{\{b,c\}} + \delta_{\{b,d\}} + \delta_{\{a,b,c\}} + \delta_{\{a,c,d\}} - \delta_{\{b,c,d\}} \\
 & = -u_{\langle b,c|\emptyset \rangle} - u_{\langle b,d|ac \rangle} + u_{\langle a,c|bd \rangle} + u_{\langle b,d|a \rangle} \\
 & = (\delta_{\{a\}} - \delta_{\{a,b\}} - \delta_{\{a,d\}} + \delta_{\{b,d\}} - \delta_{\{b,c,d\}} + \delta_{\{a,b,c,d\}}) \\
 & \quad - (\delta_{\emptyset} - \delta_{\{b\}} - \delta_{\{c\}} + \delta_{\{a,c\}} + \delta_{\{b,c\}} - \delta_{\{a,b,c\}} - \delta_{\{a,c,d\}} + \delta_{\{a,b,c,d\}})
 \end{aligned}$$

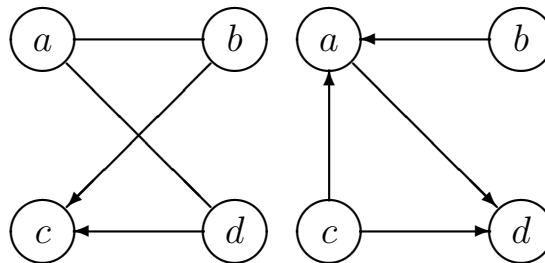

0.12.12.2 Differential imset (64)

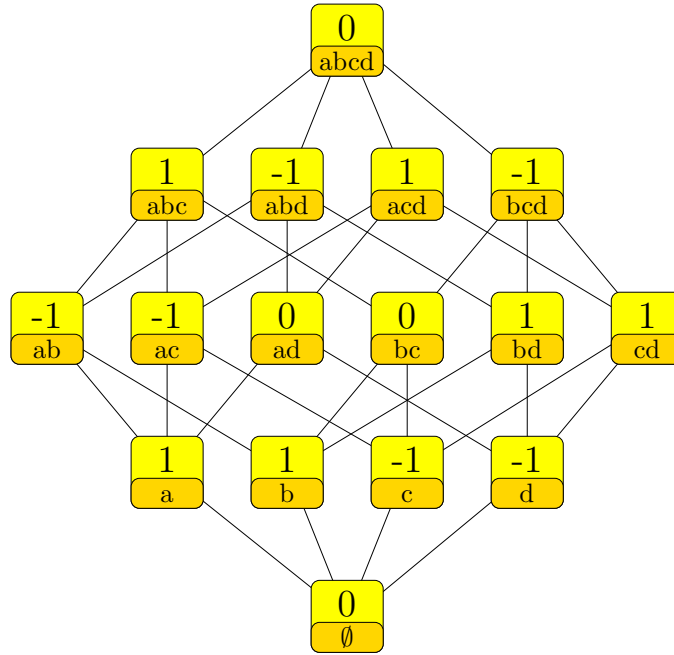

$$\begin{aligned}
 & \delta_{\{a\}} + \delta_{\{b\}} - \delta_{\{c\}} - \delta_{\{d\}} - \delta_{\{a,b\}} - \delta_{\{a,c\}} + \delta_{\{b,d\}} + \delta_{\{c,d\}} + \delta_{\{a,b,c\}} - \delta_{\{a,b,d\}} + \delta_{\{a,c,d\}} - \delta_{\{b,c,d\}} \\
 &= -u_{\langle a,b|\emptyset \rangle} + u_{\langle c,d|\emptyset \rangle} - u_{\langle b,d|ac \rangle} + u_{\langle a,c|bd \rangle} \\
 &= (\delta_{\emptyset} - \delta_{\{c\}} - \delta_{\{d\}} + \delta_{\{b,d\}} + \delta_{\{c,d\}} - \delta_{\{a,b,d\}} - \delta_{\{b,c,d\}} + \delta_{\{a,b,c,d\}}) \\
 &\quad - (\delta_{\emptyset} - \delta_{\{a\}} - \delta_{\{b\}} + \delta_{\{a,b\}} + \delta_{\{a,c\}} - \delta_{\{a,b,c\}} - \delta_{\{a,c,d\}} + \delta_{\{a,b,c,d\}})
 \end{aligned}$$

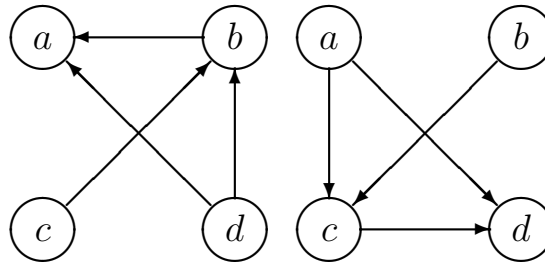

### 0.14 Squared Euclidean length 14

#### 0.14.8 Number of nonzero values 8

##### 0.14.8.1 Differential imset (65)

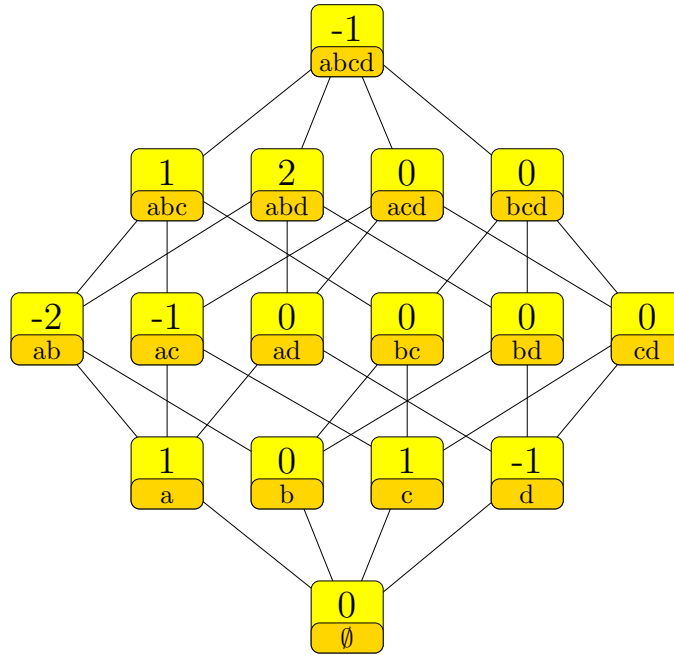

$$\begin{aligned}
 & \delta_{\{a\}} + \delta_{\{c\}} - \delta_{\{d\}} - 2\delta_{\{a,b\}} - \delta_{\{a,c\}} + \delta_{\{a,b,c\}} + 2\delta_{\{a,b,d\}} - \delta_{\{a,b,c,d\}} \\
 &= -u_{\langle a,c|\emptyset \rangle} + u_{\langle a,d|\emptyset \rangle} - u_{\langle c,d|ab \rangle} + u_{\langle b,d|a \rangle} \\
 &= (\delta_{\emptyset} - \delta_{\{d\}} - \delta_{\{a,b\}} + \delta_{\{a,b,d\}}) \\
 &\quad - (\delta_{\emptyset} - \delta_{\{a\}} - \delta_{\{c\}} + \delta_{\{a,b\}} + \delta_{\{a,c\}} - \delta_{\{a,b,c\}} - \delta_{\{a,b,d\}} + \delta_{\{a,b,c,d\}})
 \end{aligned}$$

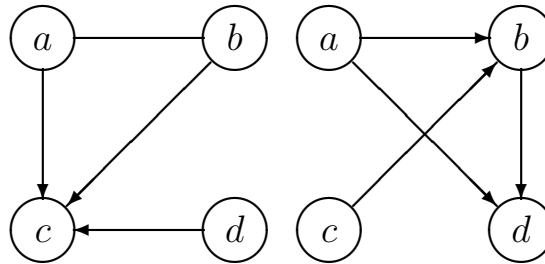

0.14.8.2 Differential imset (66)

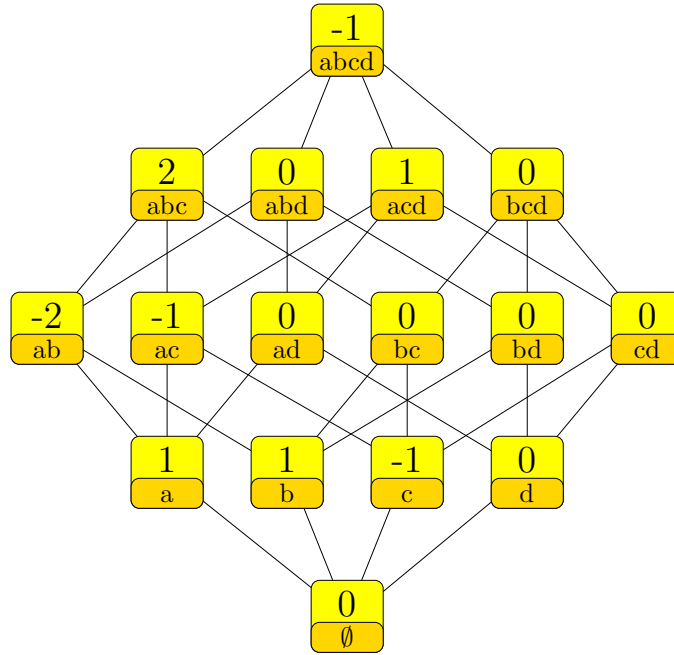

$$\begin{aligned}
 & \delta_{\{a\}} + \delta_{\{b\}} - \delta_{\{c\}} - 2\delta_{\{a,b\}} - \delta_{\{a,c\}} + 2\delta_{\{a,b,c\}} + \delta_{\{a,c,d\}} - \delta_{\{a,b,c,d\}} \\
 &= -u_{\langle a,b|\emptyset \rangle} + u_{\langle a,c|\emptyset \rangle} - u_{\langle b,d|ac \rangle} + u_{\langle b,c|a \rangle} \\
 &= (\delta_{\emptyset} - \delta_{\{c\}} - \delta_{\{a,b\}} + \delta_{\{a,b,c\}}) \\
 &\quad - (\delta_{\emptyset} - \delta_{\{a\}} - \delta_{\{b\}} + \delta_{\{a,b\}} + \delta_{\{a,c\}} - \delta_{\{a,b,c\}} - \delta_{\{a,c,d\}} + \delta_{\{a,b,c,d\}})
 \end{aligned}$$

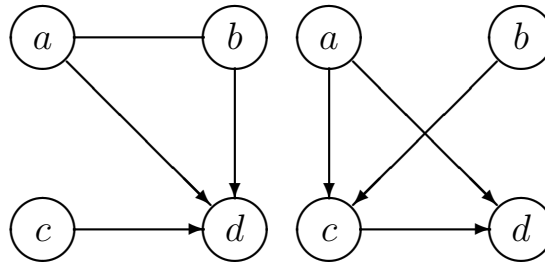

0.14.8.3 Differential imset (67)

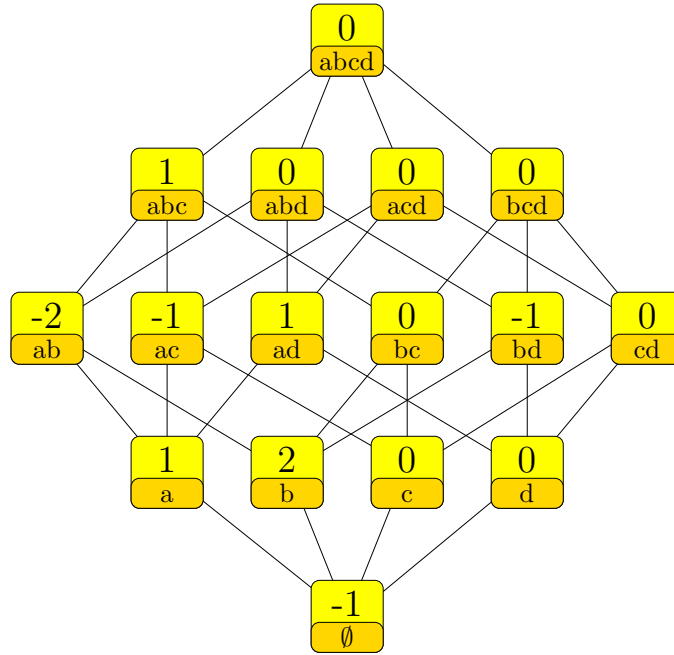

$$\begin{aligned}
 & -\delta_\emptyset + \delta_{\{a\}} + 2\delta_{\{b\}} - 2\delta_{\{a,b\}} - \delta_{\{a,c\}} + \delta_{\{a,d\}} - \delta_{\{b,d\}} + \delta_{\{a,b,c\}} \\
 &= -u_{\langle a,b|\emptyset \rangle} + u_{\langle b,c|a \rangle} - u_{\langle b,d|a \rangle} + u_{\langle a,d|b \rangle} \\
 &= (\delta_{\{a\}} + \delta_{\{b\}} - \delta_{\{a,b\}} - \delta_{\{a,c\}} - \delta_{\{b,d\}} + \delta_{\{a,b,c,d\}}) \\
 &\quad - (\delta_\emptyset - \delta_{\{b\}} + \delta_{\{a,b\}} - \delta_{\{a,d\}} - \delta_{\{a,b,c\}} + \delta_{\{a,b,c,d\}}) \\
 &= (\delta_{\{b\}} - \delta_{\{a,b\}} + \delta_{\{a,d\}} - \delta_{\{b,d\}} - \delta_{\{a,c,d\}} + \delta_{\{a,b,c,d\}}) \\
 &\quad - (\delta_\emptyset - \delta_{\{a\}} - \delta_{\{b\}} + \delta_{\{a,b\}} + \delta_{\{a,c\}} - \delta_{\{a,b,c\}} - \delta_{\{a,c,d\}} + \delta_{\{a,b,c,d\}})
 \end{aligned}$$

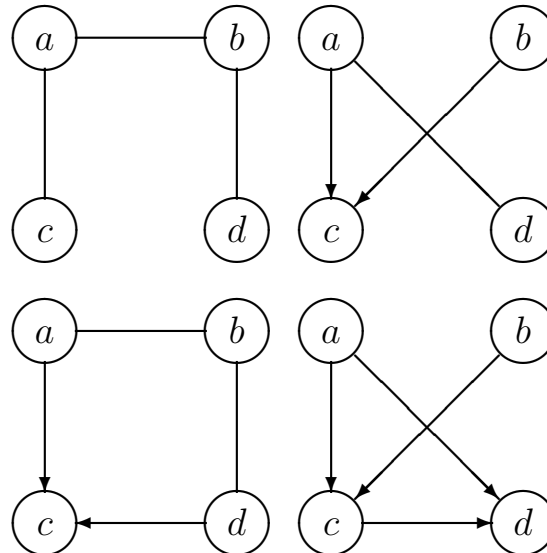

0.14.8.4 Differential imset (68)

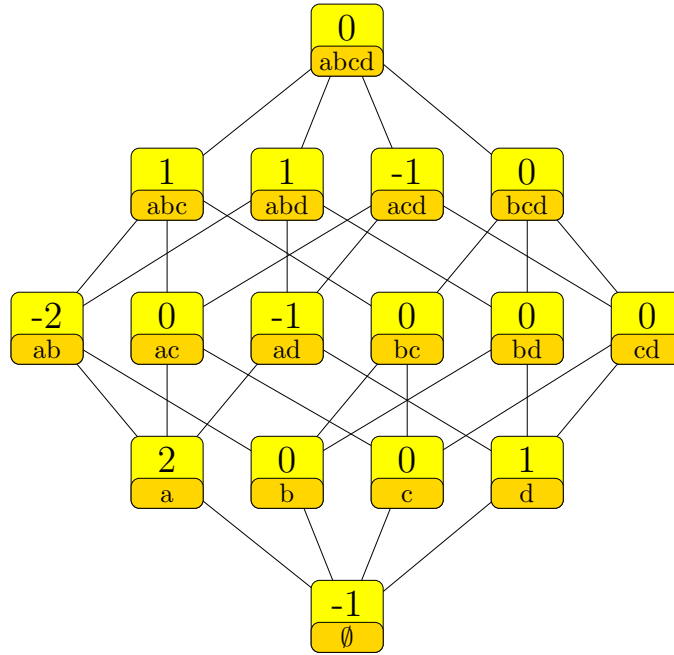

$$\begin{aligned}
 & -\delta_{\emptyset} + 2\delta_{\{a\}} + \delta_{\{d\}} - 2\delta_{\{a,b\}} - \delta_{\{a,d\}} + \delta_{\{a,b,c\}} + \delta_{\{a,b,d\}} - \delta_{\{a,c,d\}} \\
 & = -u_{\langle a,d|\emptyset \rangle} - u_{\langle c,d|ab \rangle} + u_{\langle b,d|ac \rangle} + u_{\langle b,c|a \rangle} \\
 & = (\delta_{\{a\}} - \delta_{\{a,b\}} - \delta_{\{a,c,d\}} + \delta_{\{a,b,c,d\}}) \\
 & \quad - (\delta_{\emptyset} - \delta_{\{a\}} - \delta_{\{d\}} + \delta_{\{a,b\}} + \delta_{\{a,d\}} - \delta_{\{a,b,c\}} - \delta_{\{a,b,d\}} + \delta_{\{a,b,c,d\}})
 \end{aligned}$$

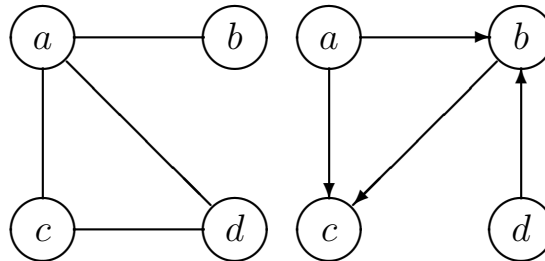



0.14.8.5 Differential imset (69)

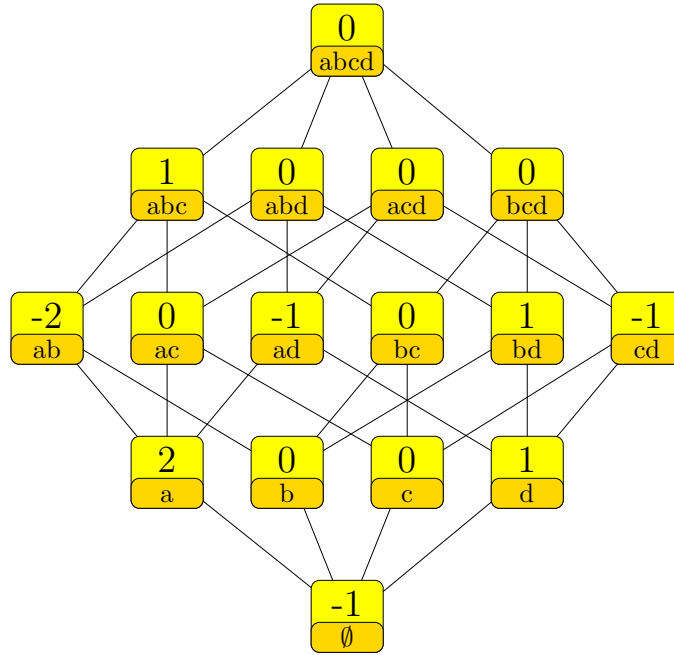

$$\begin{aligned}
 & -\delta_\emptyset + 2\delta_{\{a\}} + \delta_{\{d\}} - 2\delta_{\{a,b\}} - \delta_{\{a,d\}} + \delta_{\{b,d\}} - \delta_{\{c,d\}} + \delta_{\{a,b,c\}} \\
 &= -u_{\langle a,b|\emptyset} - u_{\langle c,d|ab} + u_{\langle b,d|ac} + u_{\langle b,c|a} - u_{\langle a,d|b} + u_{\langle a,c|d} \\
 &= (\delta_{\{a\}} + \delta_{\{d\}} - \delta_{\{a,b\}} - \delta_{\{a,d\}} - \delta_{\{c,d\}} + \delta_{\{a,b,c,d\}}) \\
 &\quad - (\delta_\emptyset - \delta_{\{a\}} + \delta_{\{a,b\}} - \delta_{\{b,d\}} - \delta_{\{a,b,c\}} + \delta_{\{a,b,c,d\}})
 \end{aligned}$$

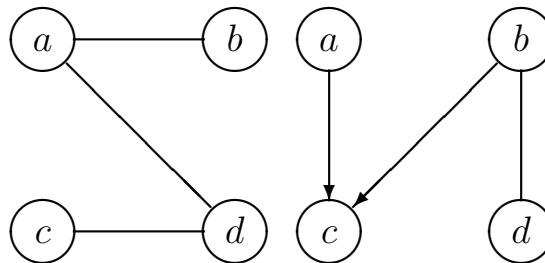

0.14.8.6 Differential imset (70)

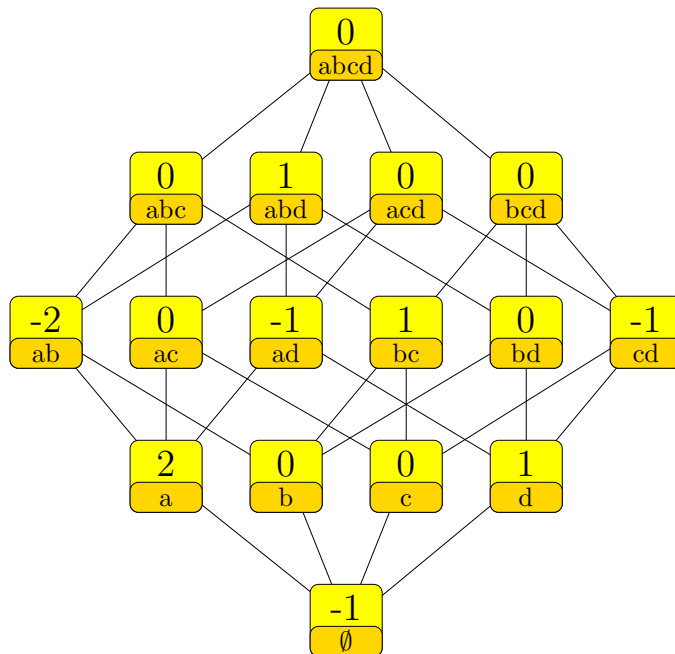

$$\begin{aligned}
 & -\delta_\emptyset + 2\delta_{\{a\}} + \delta_{\{d\}} - 2\delta_{\{a,b\}} - \delta_{\{a,d\}} + \delta_{\{b,c\}} - \delta_{\{c,d\}} + \delta_{\{a,b,d\}} \\
 &= -u_{\langle a,b|\emptyset \rangle} + u_{\langle b,c|\emptyset \rangle} - u_{\langle c,d|\emptyset \rangle} + u_{\langle b,d|a \rangle} \\
 &= (\delta_{\{a\}} + \delta_{\{d\}} - \delta_{\{a,b\}} - \delta_{\{a,d\}} - \delta_{\{c,d\}} + \delta_{\{a,b,c,d\}}) \\
 &\quad - (\delta_\emptyset - \delta_{\{a\}} + \delta_{\{a,b\}} - \delta_{\{b,c\}} - \delta_{\{a,b,d\}} + \delta_{\{a,b,c,d\}})
 \end{aligned}$$

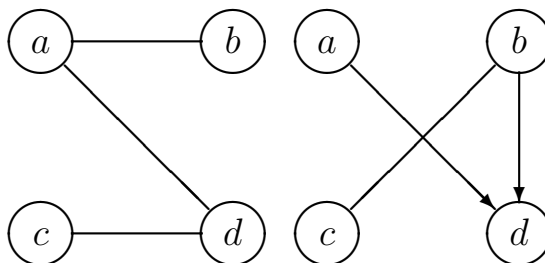

0.14.8.7 Differential imset (71)

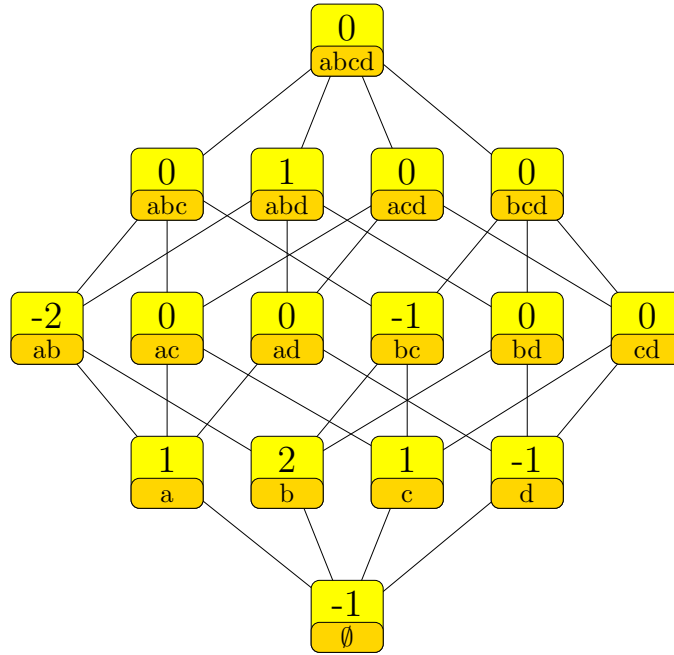

$$\begin{aligned}
 & -\delta_{\emptyset} + \delta_{\{a\}} + 2\delta_{\{b\}} + \delta_{\{c\}} - \delta_{\{d\}} - 2\delta_{\{a,b\}} - \delta_{\{b,c\}} + \delta_{\{a,b,d\}} \\
 &= -u_{\langle a,b|\emptyset \rangle} + u_{\langle a,d|\emptyset \rangle} - u_{\langle b,c|\emptyset \rangle} + u_{\langle b,d|a \rangle} \\
 &= (\delta_{\{b\}} + \delta_{\{c\}} - \delta_{\{a,b\}} - \delta_{\{b,c\}} - \delta_{\{c,d\}} + \delta_{\{a,b,c,d\}}) \\
 &\quad - (\delta_{\emptyset} - \delta_{\{a\}} - \delta_{\{b\}} + \delta_{\{d\}} + \delta_{\{a,b\}} - \delta_{\{c,d\}} - \delta_{\{a,b,d\}} + \delta_{\{a,b,c,d\}})
 \end{aligned}$$

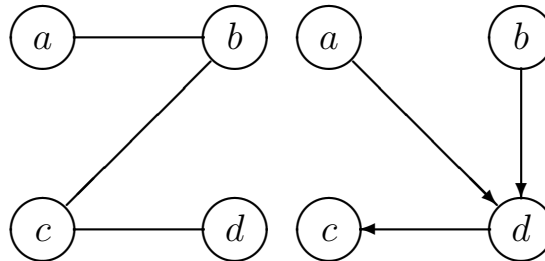

0.14.8.8 Differential imset (72)

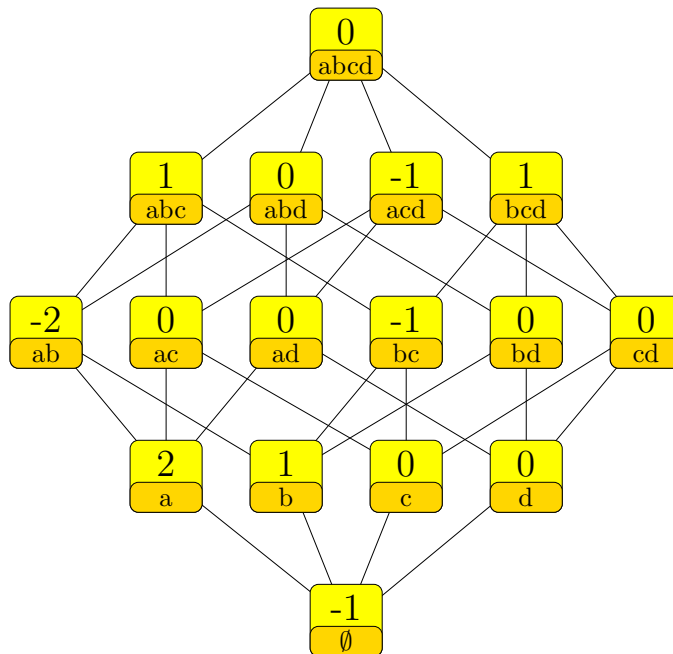

$$\begin{aligned}
 & -\delta_\emptyset + 2\delta_{\{a\}} + \delta_{\{b\}} - 2\delta_{\{a,b\}} - \delta_{\{b,c\}} + \delta_{\{a,b,c\}} - \delta_{\{a,c,d\}} + \delta_{\{b,c,d\}} \\
 &= -u_{\langle a,b|\emptyset \rangle} + u_{\langle b,d|ac \rangle} - u_{\langle a,d|bc \rangle} + u_{\langle b,c|a \rangle} \\
 &= (\delta_{\{a\}} - \delta_{\{a,b\}} - \delta_{\{a,c,d\}} + \delta_{\{a,b,c,d\}}) \\
 &\quad - (\delta_\emptyset - \delta_{\{a\}} - \delta_{\{b\}} + \delta_{\{a,b\}} + \delta_{\{b,c\}} - \delta_{\{a,b,c\}} - \delta_{\{b,c,d\}} + \delta_{\{a,b,c,d\}})
 \end{aligned}$$

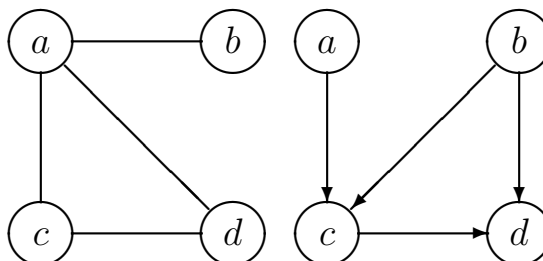

0.14.8.9 Differential imset (73)

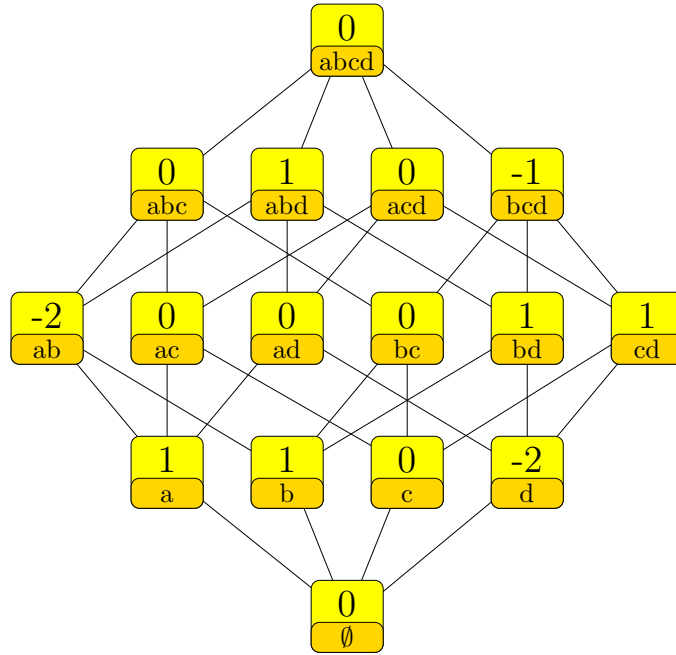

$$\begin{aligned}
 & \delta_{\{a\}} + \delta_{\{b\}} - 2\delta_{\{d\}} - 2\delta_{\{a,b\}} + \delta_{\{b,d\}} + \delta_{\{c,d\}} + \delta_{\{a,b,d\}} - \delta_{\{b,c,d\}} \\
 &= -u_{\langle a,b|\emptyset \rangle} + u_{\langle a,d|\emptyset \rangle} + u_{\langle b,d|a \rangle} - u_{\langle b,c|d \rangle} \\
 &= (\delta_{\emptyset} - \delta_{\{d\}} - \delta_{\{a,b\}} + \delta_{\{b,d\}} - \delta_{\{b,c,d\}} + \delta_{\{a,b,c,d\}}) \\
 &\quad - (\delta_{\emptyset} - \delta_{\{a\}} - \delta_{\{b\}} + \delta_{\{d\}} + \delta_{\{a,b\}} - \delta_{\{c,d\}} - \delta_{\{a,b,d\}} + \delta_{\{a,b,c,d\}})
 \end{aligned}$$

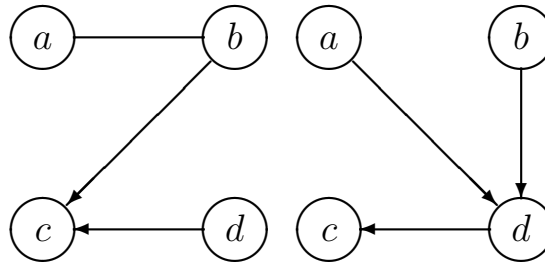

0.14.8.10 Differential imset (74)

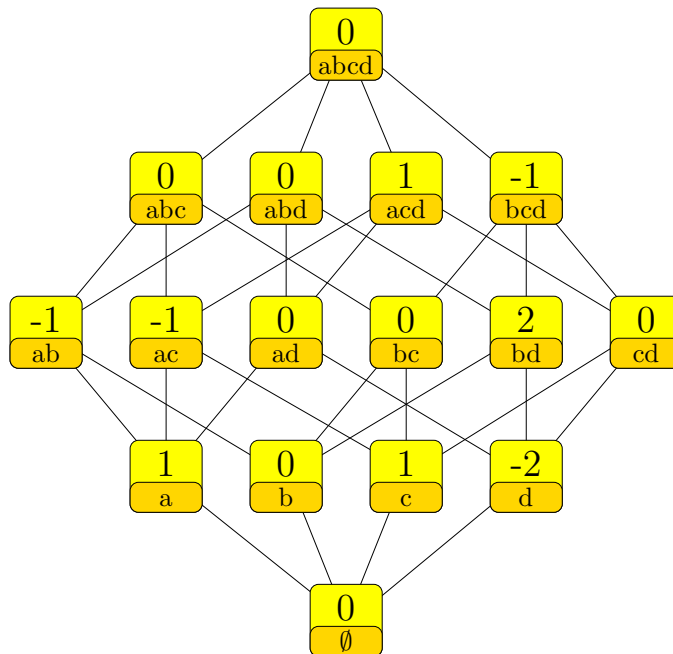

$$\begin{aligned}
 & \delta_{\{a\}} + \delta_{\{c\}} - 2\delta_{\{d\}} - \delta_{\{a,b\}} - \delta_{\{a,c\}} + 2\delta_{\{b,d\}} + \delta_{\{a,c,d\}} - \delta_{\{b,c,d\}} \\
 &= -u_{\langle a,b|\emptyset \rangle} + u_{\langle b,d|\emptyset \rangle} + u_{\langle a,d|c \rangle} - u_{\langle b,c|d \rangle} \\
 &= (\delta_{\emptyset} - \delta_{\{d\}} - \delta_{\{a,b\}} + \delta_{\{b,d\}} - \delta_{\{b,c,d\}} + \delta_{\{a,b,c,d\}}) \\
 &\quad - (\delta_{\emptyset} - \delta_{\{a\}} - \delta_{\{c\}} + \delta_{\{d\}} + \delta_{\{a,c\}} - \delta_{\{b,d\}} - \delta_{\{a,c,d\}} + \delta_{\{a,b,c,d\}})
 \end{aligned}$$

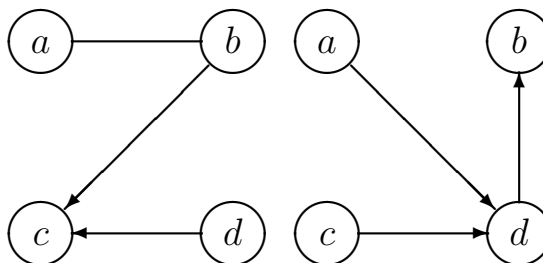

0.14.8.11 Differential imset (75)

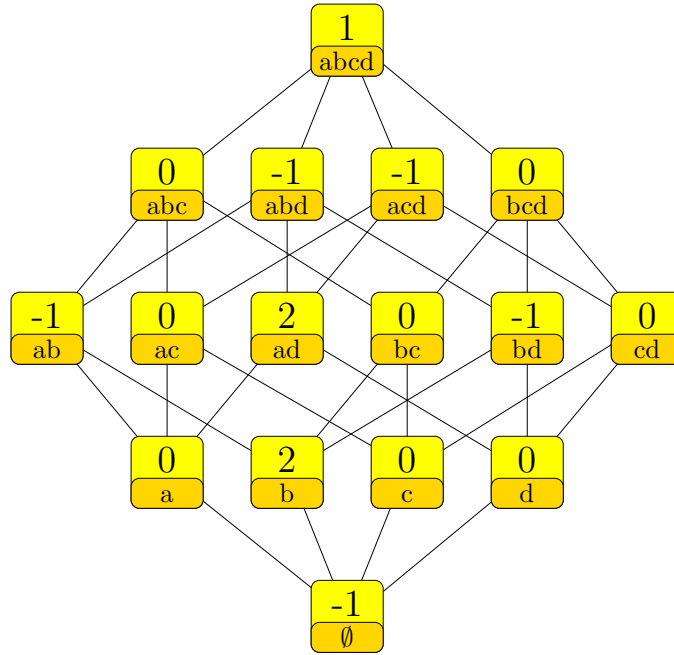

$$\begin{aligned}
 & -\delta_\emptyset + 2\delta_{\{b\}} - \delta_{\{a,b\}} + 2\delta_{\{a,d\}} - \delta_{\{b,d\}} - \delta_{\{a,b,d\}} - \delta_{\{a,c,d\}} + \delta_{\{a,b,c,d\}} \\
 &= -u_{\langle a,b|\emptyset \rangle} + u_{\langle b,c|ad \rangle} - u_{\langle b,d|a \rangle} + u_{\langle a,d|b \rangle} \\
 &= (\delta_{\{b\}} - \delta_{\{a,b\}} + \delta_{\{a,d\}} - \delta_{\{b,d\}} - \delta_{\{a,c,d\}} + \delta_{\{a,b,c,d\}}) \\
 &\quad - (\delta_\emptyset - \delta_{\{b\}} - \delta_{\{a,d\}} + \delta_{\{a,b,d\}})
 \end{aligned}$$

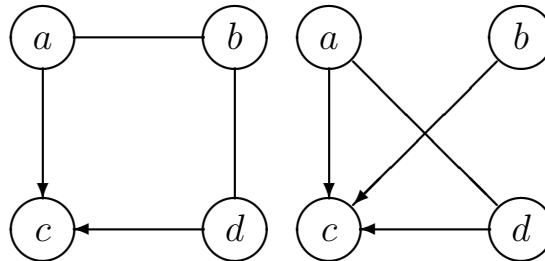

0.14.8.12 Differential imset (76)

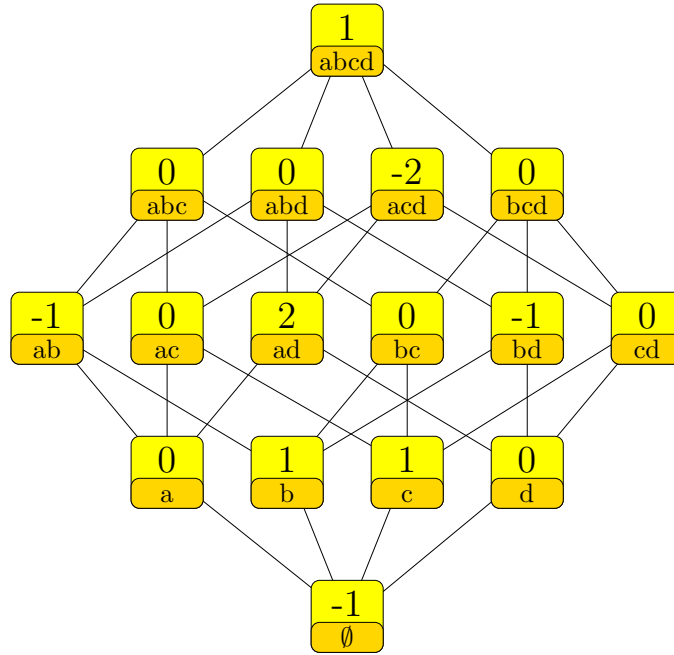

$$\begin{aligned}
 & -\delta_{\emptyset} + \delta_{\{b\}} + \delta_{\{c\}} - \delta_{\{a,b\}} + 2\delta_{\{a,d\}} - \delta_{\{b,d\}} - 2\delta_{\{a,c,d\}} + \delta_{\{a,b,c,d\}} \\
 &= -u_{\langle a,c|\emptyset \rangle} + u_{\langle b,c|ad \rangle} + u_{\langle a,d|b \rangle} - u_{\langle c,d|a \rangle} \\
 &= (\delta_{\{b\}} - \delta_{\{a,b\}} + \delta_{\{a,d\}} - \delta_{\{b,d\}} - \delta_{\{a,c,d\}} + \delta_{\{a,b,c,d\}}) \\
 &\quad - (\delta_{\emptyset} - \delta_{\{c\}} - \delta_{\{a,d\}} + \delta_{\{a,c,d\}})
 \end{aligned}$$

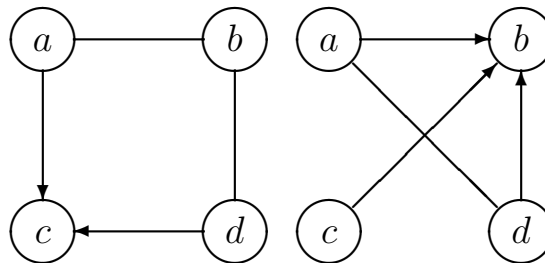



0.14.11 Number of nonzero values 11

0.14.11.1 Differential imset (77)

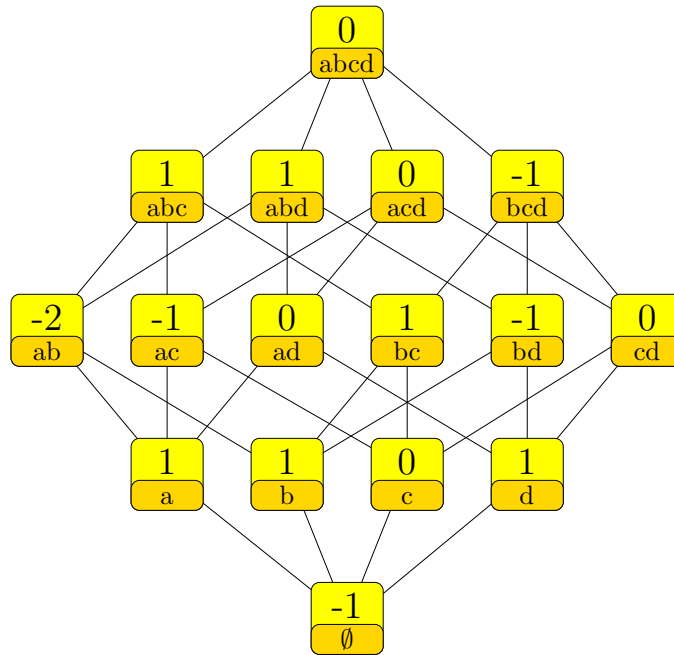

$$\begin{aligned}
 & -\delta_{\emptyset} + \delta_{\{a\}} + \delta_{\{b\}} + \delta_{\{d\}} - 2\delta_{\{a,b\}} - \delta_{\{a,c\}} + \delta_{\{b,c\}} - \delta_{\{b,d\}} + \delta_{\{a,b,c\}} + \delta_{\{a,b,d\}} - \delta_{\{b,c,d\}} \\
 & = -u_{\langle b,d|\emptyset \rangle} - u_{\langle c,d|ab \rangle} + u_{\langle a,d|bc \rangle} + u_{\langle b,c|a \rangle} \\
 & = (\delta_{\{a\}} - \delta_{\{a,b\}} - \delta_{\{a,c\}} + \delta_{\{b,c\}} - \delta_{\{b,c,d\}} + \delta_{\{a,b,c,d\}}) \\
 & \quad - (\delta_{\emptyset} - \delta_{\{b\}} - \delta_{\{d\}} + \delta_{\{a,b\}} + \delta_{\{b,d\}} - \delta_{\{a,b,c\}} - \delta_{\{a,b,d\}} + \delta_{\{a,b,c,d\}})
 \end{aligned}$$

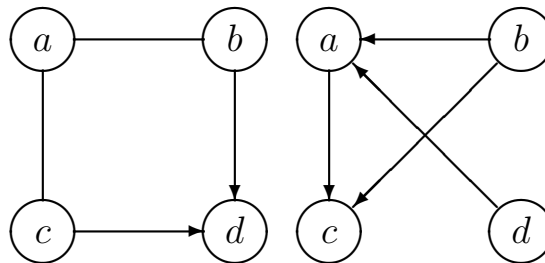

0.14.11.2 Differential imset (78)

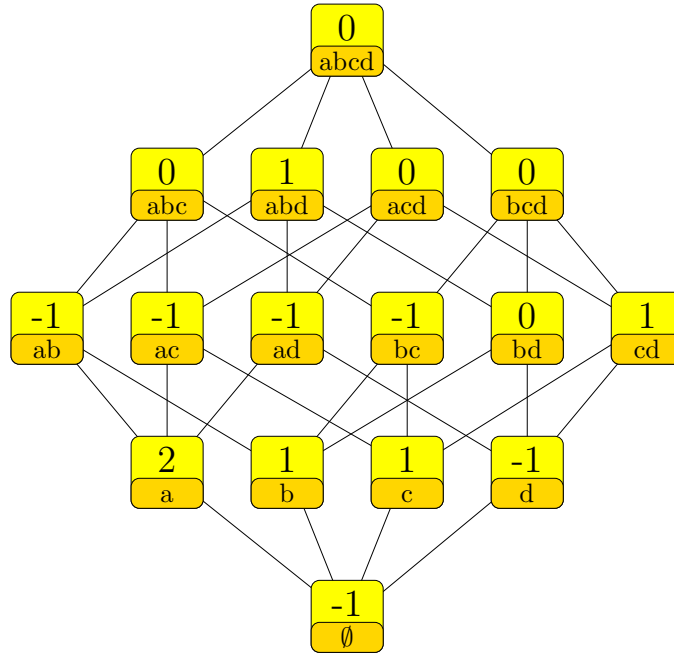

$$\begin{aligned}
 & -\delta_{\emptyset} + 2\delta_{\{a\}} + \delta_{\{b\}} + \delta_{\{c\}} - \delta_{\{d\}} - \delta_{\{a,b\}} - \delta_{\{a,c\}} - \delta_{\{a,d\}} - \delta_{\{b,c\}} + \delta_{\{c,d\}} + \delta_{\{a,b,d\}} \\
 &= -u_{\langle a,c|\emptyset} - u_{\langle b,c|\emptyset} + u_{\langle c,d|\emptyset} + u_{\langle b,d|a} \\
 &= (\delta_{\{a\}} + \delta_{\{c\}} - \delta_{\{a,c\}} - \delta_{\{a,d\}} - \delta_{\{b,c\}} + \delta_{\{a,b,c,d\}}) \\
 &\quad - (\delta_{\emptyset} - \delta_{\{a\}} - \delta_{\{b\}} + \delta_{\{d\}} + \delta_{\{a,b\}} - \delta_{\{c,d\}} - \delta_{\{a,b,d\}} + \delta_{\{a,b,c,d\}})
 \end{aligned}$$

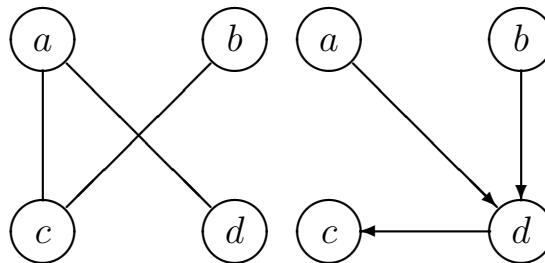

### 0.16 Squared Euclidean length 16

#### 0.16.10 Number of nonzero values 10

##### 0.16.10.1 Differential imset (79)

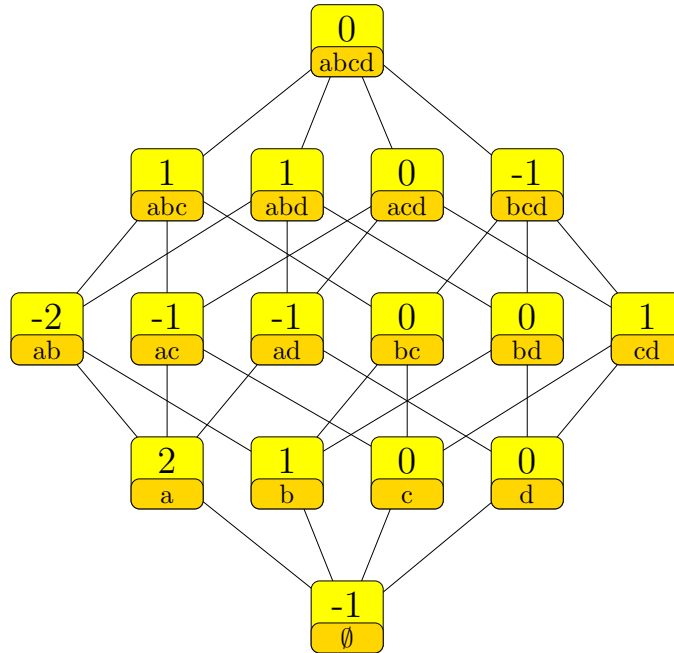

$$\begin{aligned}
 & -\delta_{\emptyset} + 2\delta_{\{a\}} + \delta_{\{b\}} - 2\delta_{\{a,b\}} - \delta_{\{a,c\}} - \delta_{\{a,d\}} + \delta_{\{c,d\}} + \delta_{\{a,b,c\}} + \delta_{\{a,b,d\}} - \delta_{\{b,c,d\}} \\
 &= -u_{\langle a,b|\emptyset \rangle} - u_{\langle c,d|ab \rangle} + u_{\langle a,b|cd \rangle} + u_{\langle c,d|a \rangle} \\
 &= (\delta_{\{a\}} - \delta_{\{a,c\}} - \delta_{\{a,d\}} + \delta_{\{c,d\}} - \delta_{\{b,c,d\}} + \delta_{\{a,b,c,d\}}) \\
 &\quad - (\delta_{\emptyset} - \delta_{\{a\}} - \delta_{\{b\}} + 2\delta_{\{a,b\}} - \delta_{\{a,b,c\}} - \delta_{\{a,b,d\}} + \delta_{\{a,b,c,d\}})
 \end{aligned}$$

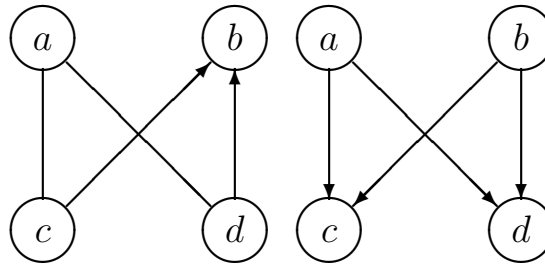

0.16.10.2 Differential imset (80)

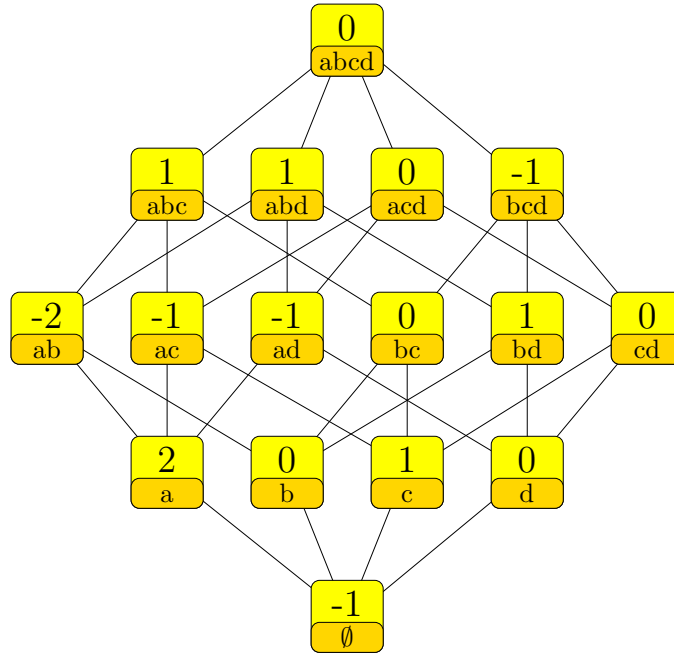

$$\begin{aligned}
 & -\delta_{\emptyset} + 2\delta_{\{a\}} + \delta_{\{c\}} - 2\delta_{\{a,b\}} - \delta_{\{a,c\}} - \delta_{\{a,d\}} + \delta_{\{b,d\}} + \delta_{\{a,b,c\}} + \delta_{\{a,b,d\}} - \delta_{\{b,c,d\}} \\
 & = -u_{\langle a,c|\emptyset\rangle} - u_{\langle c,d|ab\rangle} + u_{\langle a,c|bd\rangle} + u_{\langle b,d|a\rangle} \\
 & = (\delta_{\{a\}} - \delta_{\{a,b\}} - \delta_{\{a,d\}} + \delta_{\{b,d\}} - \delta_{\{b,c,d\}} + \delta_{\{a,b,c,d\}}) \\
 & \quad - (\delta_{\emptyset} - \delta_{\{a\}} - \delta_{\{c\}} + \delta_{\{a,b\}} + \delta_{\{a,c\}} - \delta_{\{a,b,c\}} - \delta_{\{a,b,d\}} + \delta_{\{a,b,c,d\}})
 \end{aligned}$$

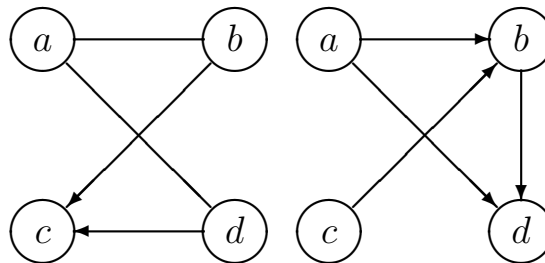

0.16.10.3 Differential imset (81)

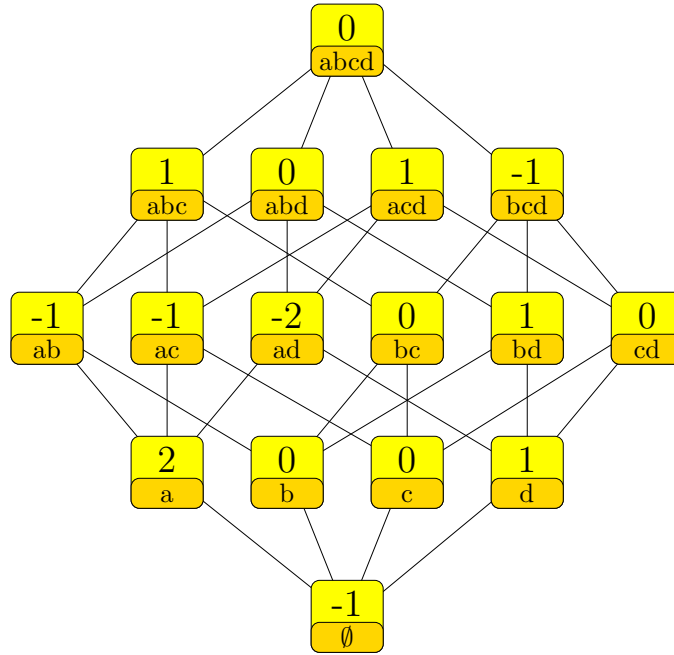

$$\begin{aligned}
 & -\delta_{\emptyset} + 2\delta_{\{a\}} + \delta_{\{d\}} - \delta_{\{a,b\}} - \delta_{\{a,c\}} - 2\delta_{\{a,d\}} + \delta_{\{b,d\}} + \delta_{\{a,b,c\}} + \delta_{\{a,c,d\}} - \delta_{\{b,c,d\}} \\
 &= -u_{\langle a,d|\emptyset \rangle} - u_{\langle b,d|ac \rangle} + u_{\langle a,c|bd \rangle} + u_{\langle b,d|a \rangle} \\
 &= (\delta_{\{a\}} - \delta_{\{a,b\}} - \delta_{\{a,d\}} + \delta_{\{b,d\}} - \delta_{\{b,c,d\}} + \delta_{\{a,b,c,d\}}) \\
 &\quad - (\delta_{\emptyset} - \delta_{\{a\}} - \delta_{\{d\}} + \delta_{\{a,c\}} + \delta_{\{a,d\}} - \delta_{\{a,b,c\}} - \delta_{\{a,c,d\}} + \delta_{\{a,b,c,d\}})
 \end{aligned}$$

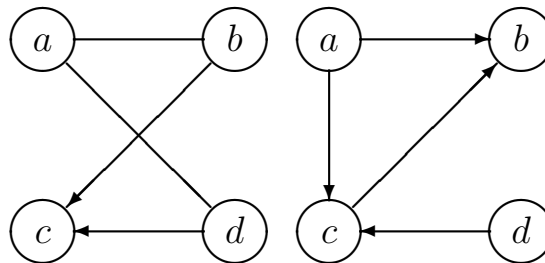

0.16.10.4 Differential imset (82)

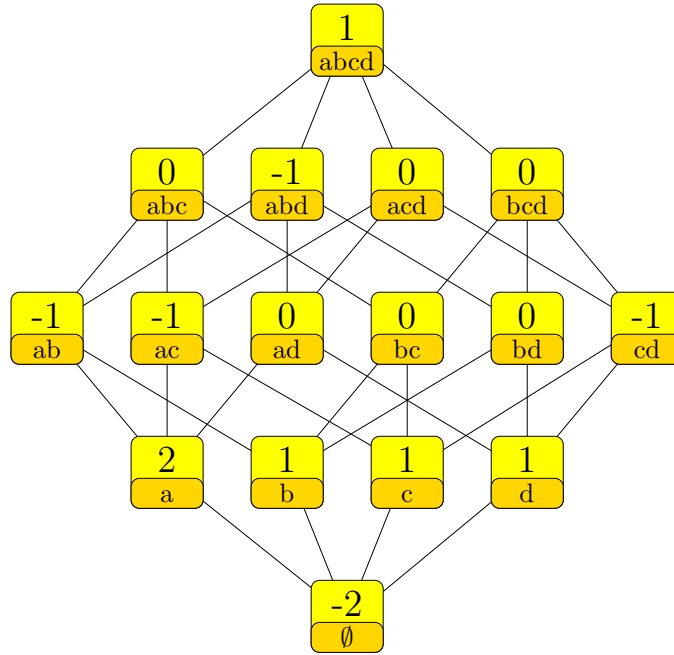

$$\begin{aligned}
 & -2\delta_\emptyset + 2\delta_{\{a\}} + \delta_{\{b\}} + \delta_{\{c\}} + \delta_{\{d\}} - \delta_{\{a,b\}} - \delta_{\{a,c\}} - \delta_{\{c,d\}} - \delta_{\{a,b,d\}} + \delta_{\{a,b,c,d\}} \\
 &= -u_{\langle a,b|\emptyset \rangle} - u_{\langle a,d|\emptyset \rangle} + u_{\langle b,c|ad \rangle} + u_{\langle a,d|c \rangle} \\
 &= (\delta_{\{a\}} + \delta_{\{c\}} - \delta_{\{a,b\}} - \delta_{\{a,c\}} - \delta_{\{c,d\}} + \delta_{\{a,b,c,d\}}) \\
 &\quad - (+2\delta_\emptyset - \delta_{\{a\}} - \delta_{\{b\}} - \delta_{\{d\}} + \delta_{\{a,b,d\}})
 \end{aligned}$$

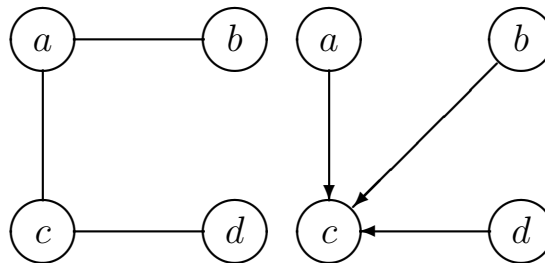

### 0.18 Squared Euclidean length 18

#### 0.18.7 Number of nonzero values 7

##### 0.18.7.1 Differential imset (83)

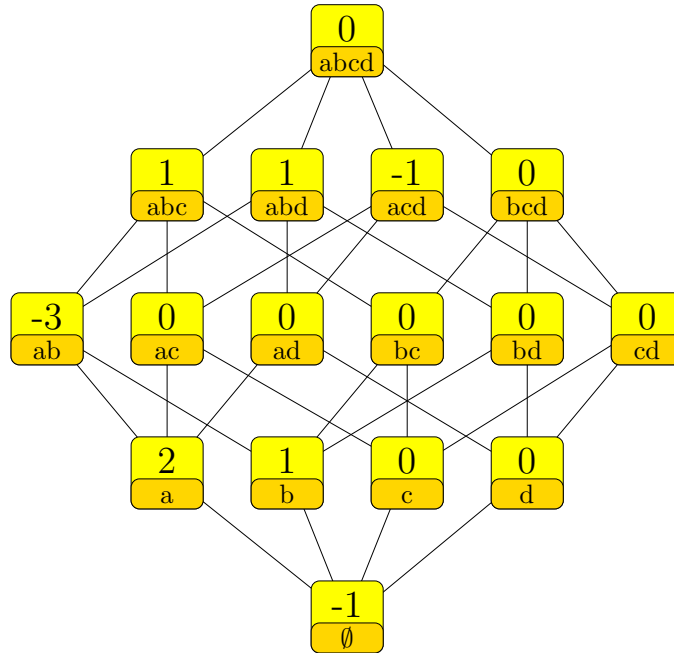

$$\begin{aligned}
 & -\delta_{\emptyset} + 2\delta_{\{a\}} + \delta_{\{b\}} - 3\delta_{\{a,b\}} + \delta_{\{a,b,c\}} + \delta_{\{a,b,d\}} - \delta_{\{a,c,d\}} \\
 &= -u_{\langle a,b|\emptyset \rangle} - u_{\langle c,d|ab \rangle} + u_{\langle b,d|ac \rangle} + u_{\langle b,c|a \rangle} \\
 &= (\delta_{\{a\}} - \delta_{\{a,b\}} - \delta_{\{a,c,d\}} + \delta_{\{a,b,c,d\}}) \\
 &\quad - (\delta_{\emptyset} - \delta_{\{a\}} - \delta_{\{b\}} + 2\delta_{\{a,b\}} - \delta_{\{a,b,c\}} - \delta_{\{a,b,d\}} + \delta_{\{a,b,c,d\}})
 \end{aligned}$$

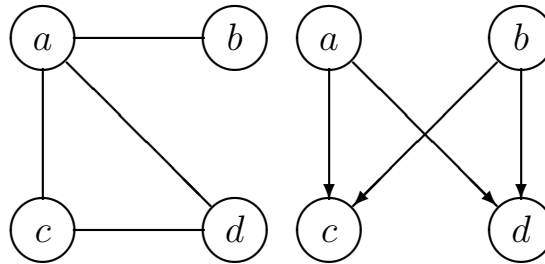

0.18.7.2 Differential imset (84)

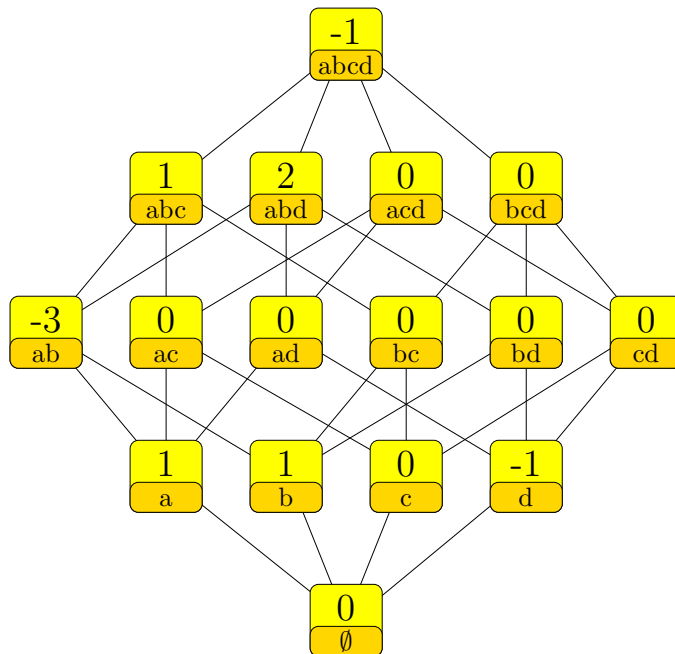

$$\begin{aligned}
 & \delta_{\{a\}} + \delta_{\{b\}} - \delta_{\{d\}} - 3\delta_{\{a,b\}} + \delta_{\{a,b,c\}} + 2\delta_{\{a,b,d\}} - \delta_{\{a,b,c,d\}} \\
 &= -u_{\langle a,b|\emptyset \rangle} + u_{\langle a,d|\emptyset \rangle} - u_{\langle c,d|ab \rangle} + u_{\langle b,d|a \rangle} \\
 &= (\delta_{\emptyset} - \delta_{\{d\}} - \delta_{\{a,b\}} + \delta_{\{a,b,d\}}) \\
 &\quad - (\delta_{\emptyset} - \delta_{\{a\}} - \delta_{\{b\}} + 2\delta_{\{a,b\}} - \delta_{\{a,b,c\}} - \delta_{\{a,b,d\}} + \delta_{\{a,b,c,d\}})
 \end{aligned}$$

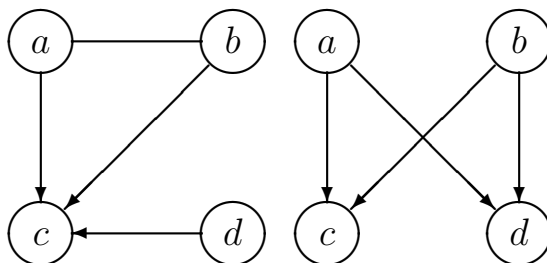



0.18.9 Number of nonzero values 9

0.18.9.1 Differential imset (85)

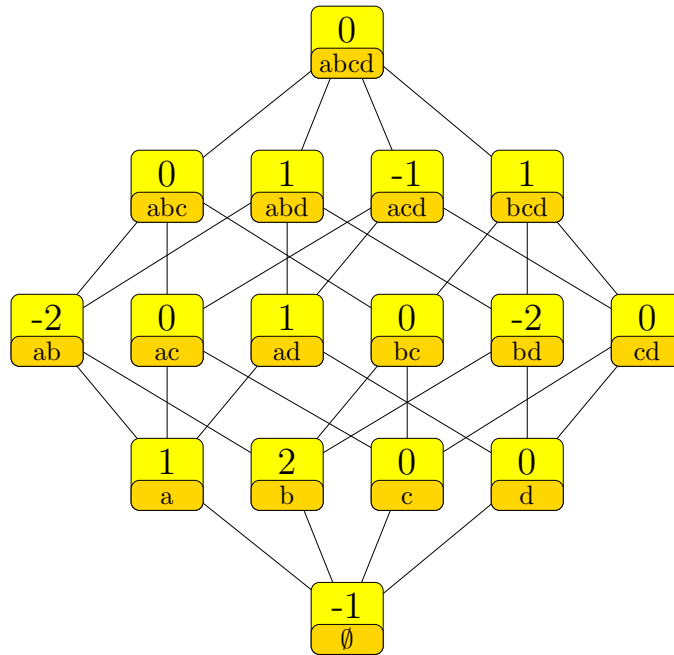

$$\begin{aligned}
 & -\delta_{\emptyset} + \delta_{\{a\}} + 2\delta_{\{b\}} - 2\delta_{\{a,b\}} + \delta_{\{a,d\}} - 2\delta_{\{b,d\}} + \delta_{\{a,b,d\}} - \delta_{\{a,c,d\}} + \delta_{\{b,c,d\}} \\
 &= -u_{\langle a,b|\emptyset \rangle} + u_{\langle b,c|ad \rangle} - u_{\langle a,c|bd \rangle} + u_{\langle a,d|b \rangle} \\
 &= (\delta_{\{b\}} - \delta_{\{a,b\}} + \delta_{\{a,d\}} - \delta_{\{b,d\}} - \delta_{\{a,c,d\}} + \delta_{\{a,b,c,d\}}) \\
 &\quad - (\delta_{\emptyset} - \delta_{\{a\}} - \delta_{\{b\}} + \delta_{\{a,b\}} + \delta_{\{b,d\}} - \delta_{\{a,b,d\}} - \delta_{\{b,c,d\}} + \delta_{\{a,b,c,d\}})
 \end{aligned}$$

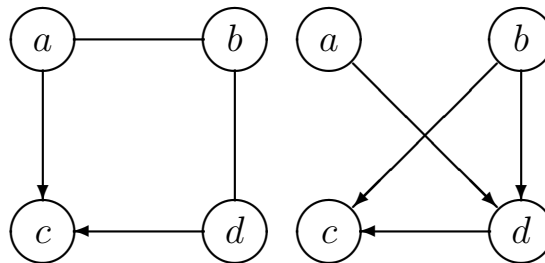

0.18.9.2 Differential imset (86)

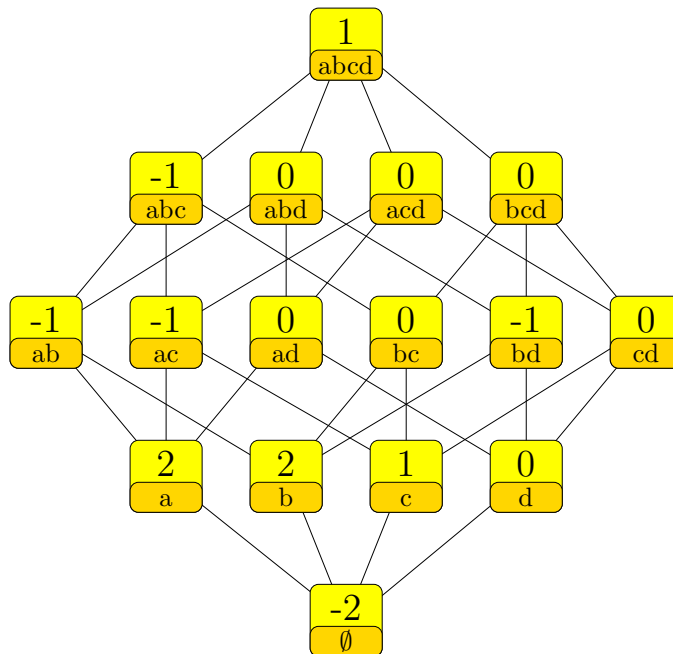

$$\begin{aligned}
 & -2\delta_\emptyset + 2\delta_{\{a\}} + 2\delta_{\{b\}} + \delta_{\{c\}} - \delta_{\{a,b\}} - \delta_{\{a,c\}} - \delta_{\{b,d\}} - \delta_{\{a,b,c\}} + \delta_{\{a,b,c,d\}} \\
 &= -u_{\langle a,b|\emptyset \rangle} - u_{\langle a,c|\emptyset \rangle} + u_{\langle c,d|ab \rangle} + u_{\langle a,d|b \rangle} \\
 &= (\delta_{\{a\}} + \delta_{\{b\}} - \delta_{\{a,b\}} - \delta_{\{a,c\}} - \delta_{\{b,d\}} + \delta_{\{a,b,c,d\}}) \\
 &\quad - (+2\delta_\emptyset - \delta_{\{a\}} - \delta_{\{b\}} - \delta_{\{c\}} + \delta_{\{a,b,c\}})
 \end{aligned}$$

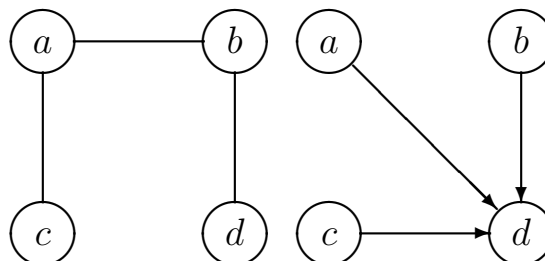

0.18.9.3 Differential imset (87)

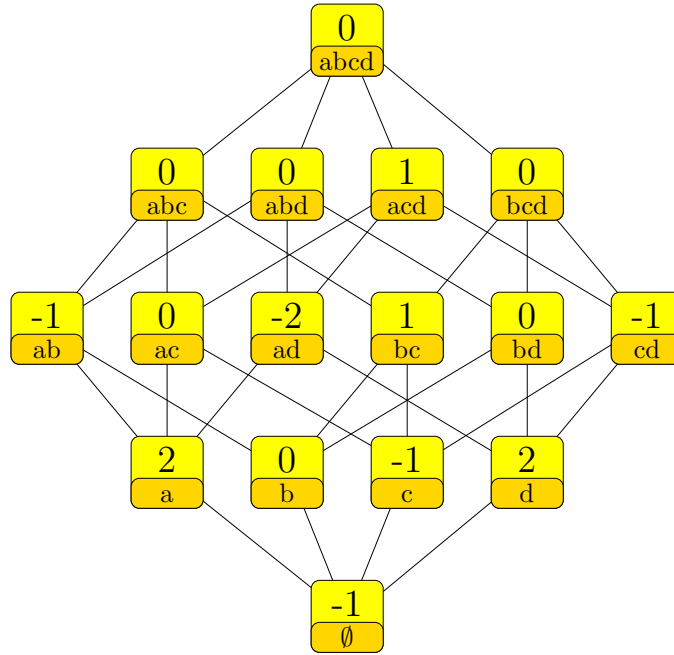

$$\begin{aligned}
 & -\delta_{\emptyset} + 2\delta_{\{a\}} - \delta_{\{c\}} + 2\delta_{\{d\}} - \delta_{\{a,b\}} - 2\delta_{\{a,d\}} + \delta_{\{b,c\}} - \delta_{\{c,d\}} + \delta_{\{a,c,d\}} \\
 &= -u_{\langle a,d|\emptyset \rangle} + u_{\langle b,c|a \rangle} - u_{\langle a,b|c \rangle} + u_{\langle a,c|d \rangle} \\
 &= (\delta_{\{a\}} + \delta_{\{d\}} - \delta_{\{a,b\}} - \delta_{\{a,d\}} - \delta_{\{c,d\}} + \delta_{\{a,b,c,d\}}) \\
 &\quad - (\delta_{\emptyset} - \delta_{\{a\}} + \delta_{\{c\}} - \delta_{\{d\}} + \delta_{\{a,d\}} - \delta_{\{b,c\}} - \delta_{\{a,c,d\}} + \delta_{\{a,b,c,d\}})
 \end{aligned}$$

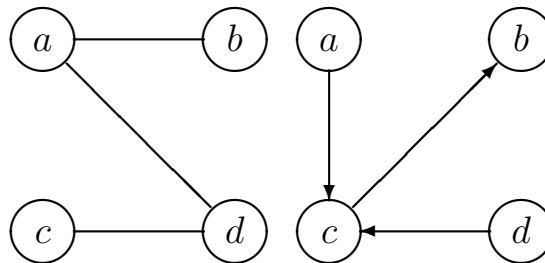

## 0.20 Squared Euclidean length 20

### 0.20.9 Number of nonzero values 9

#### 0.20.9.1 Differential imset (88)

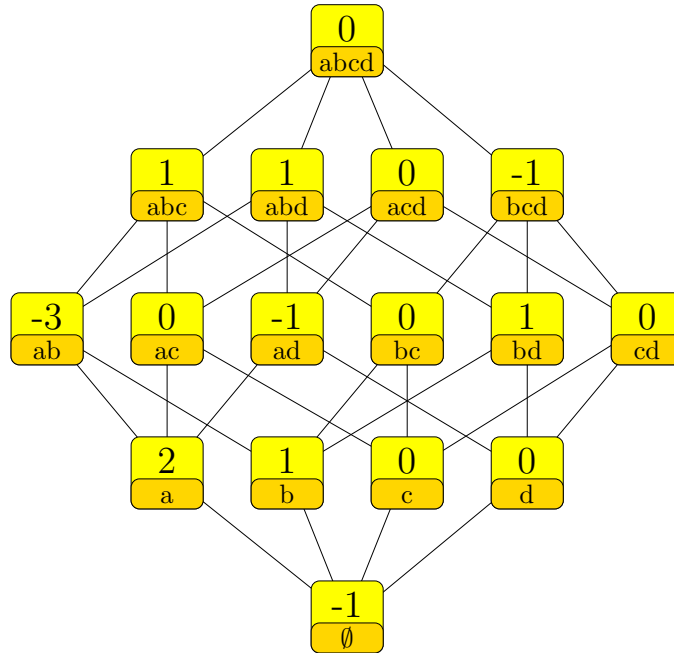

$$\begin{aligned}
 & -\delta_{\emptyset} + 2\delta_{\{a\}} + \delta_{\{b\}} - 3\delta_{\{a,b\}} - \delta_{\{a,d\}} + \delta_{\{b,d\}} + \delta_{\{a,b,c\}} + \delta_{\{a,b,d\}} - \delta_{\{b,c,d\}} \\
 &= -u_{\langle a,b|\emptyset \rangle} - u_{\langle c,d|ab \rangle} + u_{\langle a,c|bd \rangle} + u_{\langle b,d|a \rangle} \\
 &= (\delta_{\{a\}} - \delta_{\{a,b\}} - \delta_{\{a,d\}} + \delta_{\{b,d\}} - \delta_{\{b,c,d\}} + \delta_{\{a,b,c,d\}}) \\
 &\quad - (\delta_{\emptyset} - \delta_{\{a\}} - \delta_{\{b\}} + 2\delta_{\{a,b\}} - \delta_{\{a,b,c\}} - \delta_{\{a,b,d\}} + \delta_{\{a,b,c,d\}})
 \end{aligned}$$

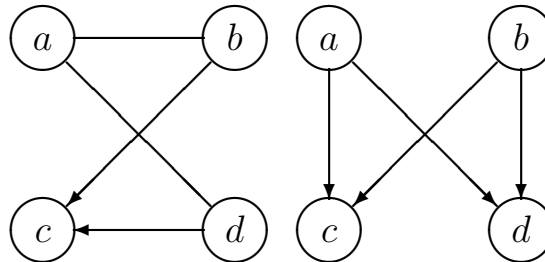

# Chapter 1

## Degree difference 1

### 1.4 Squared Euclidean length 4

#### 1.4.4 Number of nonzero values 4

##### 1.4.4.1 Differential imset (89)

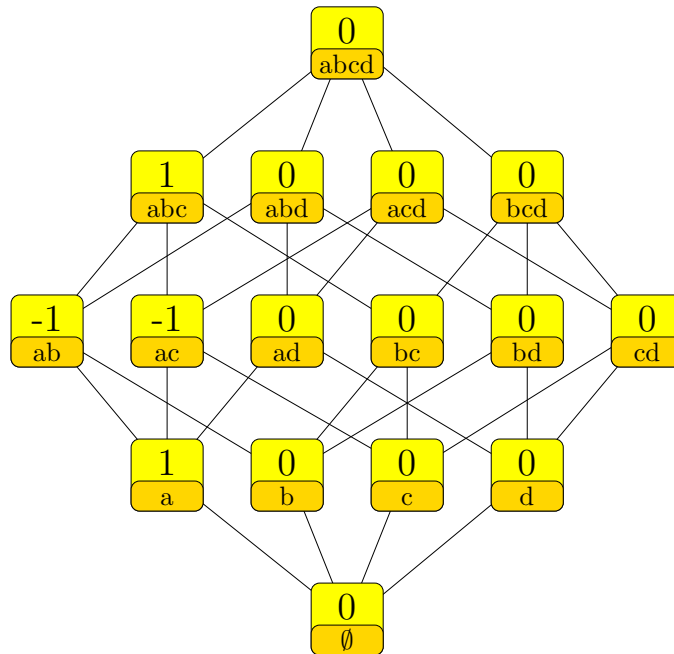

$$\begin{aligned}
 & \delta_{\{a\}} - \delta_{\{a,b\}} - \delta_{\{a,c\}} + \delta_{\{a,b,c\}} \\
 &= u_{(b,c|a)} \\
 &= (+2\delta_{\emptyset} - \delta_{\{c\}} - \delta_{\{d\}} - \delta_{\{a,b\}} + \delta_{\{a,b,c,d\}}) \\
 &\quad - (+2\delta_{\emptyset} - \delta_{\{a\}} - \delta_{\{c\}} - \delta_{\{d\}} + \delta_{\{a,c\}} - \delta_{\{a,b,c\}} + \delta_{\{a,b,c,d\}}) \\
 &= (+2\delta_{\emptyset} - \delta_{\{b\}} - \delta_{\{d\}} - \delta_{\{a,c\}} + \delta_{\{a,b,c,d\}}) \\
 &\quad - (+2\delta_{\emptyset} - \delta_{\{a\}} - \delta_{\{b\}} - \delta_{\{d\}} + \delta_{\{a,b\}} - \delta_{\{a,b,c\}} + \delta_{\{a,b,c,d\}}) \\
 &= (\delta_{\emptyset} + \delta_{\{a\}} - \delta_{\{c\}} - \delta_{\{a,b\}} - \delta_{\{a,d\}} + \delta_{\{a,b,c,d\}}) \\
 &\quad - (\delta_{\emptyset} - \delta_{\{c\}} + \delta_{\{a,c\}} - \delta_{\{a,d\}} - \delta_{\{a,b,c\}} + \delta_{\{a,b,c,d\}}) \\
 &= (\delta_{\emptyset} + \delta_{\{b\}} - \delta_{\{c\}} - \delta_{\{a,b\}} - \delta_{\{b,d\}} + \delta_{\{a,b,c,d\}}) \\
 &\quad - (\delta_{\emptyset} - \delta_{\{a\}} + \delta_{\{b\}} - \delta_{\{c\}} + \delta_{\{a,c\}} - \delta_{\{b,d\}} - \delta_{\{a,b,c\}} + \delta_{\{a,b,c,d\}}) \\
 &= (\delta_{\emptyset} - \delta_{\{b\}} + \delta_{\{c\}} - \delta_{\{a,c\}} - \delta_{\{c,d\}} + \delta_{\{a,b,c,d\}}) \\
 &\quad - (\delta_{\emptyset} - \delta_{\{a\}} - \delta_{\{b\}} + \delta_{\{c\}} + \delta_{\{a,b\}} - \delta_{\{c,d\}} - \delta_{\{a,b,c\}} + \delta_{\{a,b,c,d\}}) \\
 &= (\delta_{\emptyset} - \delta_{\{a,c\}} - \delta_{\{b,d\}} + \delta_{\{a,b,c,d\}}) \\
 &\quad - (\delta_{\emptyset} - \delta_{\{a\}} + \delta_{\{a,b\}} - \delta_{\{b,d\}} - \delta_{\{a,b,c\}} + \delta_{\{a,b,c,d\}})
 \end{aligned}$$

$$\begin{aligned}
 &= (\delta_{\{a\}} + \delta_{\{d\}} - \delta_{\{a,b\}} - \delta_{\{a,d\}} - \delta_{\{c,d\}} + \delta_{\{a,b,c,d\}}) \\
 &\quad - (\delta_{\{d\}} + \delta_{\{a,c\}} - \delta_{\{a,d\}} - \delta_{\{c,d\}} - \delta_{\{a,b,c\}} + \delta_{\{a,b,c,d\}}) \\
 &= (\delta_{\emptyset} - \delta_{\{d\}} - \delta_{\{a,b\}} + \delta_{\{a,d\}} - \delta_{\{a,c,d\}} + \delta_{\{a,b,c,d\}}) \\
 &\quad - (\delta_{\emptyset} - \delta_{\{a\}} - \delta_{\{d\}} + \delta_{\{a,c\}} + \delta_{\{a,d\}} - \delta_{\{a,b,c\}} - \delta_{\{a,c,d\}} + \delta_{\{a,b,c,d\}}) \\
 &= (\delta_{\emptyset} - \delta_{\{b\}} - \delta_{\{a,c\}} + \delta_{\{b,c\}} - \delta_{\{b,c,d\}} + \delta_{\{a,b,c,d\}}) \\
 &\quad - (\delta_{\emptyset} - \delta_{\{a\}} - \delta_{\{b\}} + \delta_{\{a,b\}} + \delta_{\{b,c\}} - \delta_{\{a,b,c\}} - \delta_{\{b,c,d\}} + \delta_{\{a,b,c,d\}}) \\
 &= (\delta_{\emptyset} - \delta_{\{b\}} + \delta_{\{a,b\}} - \delta_{\{a,c\}} - \delta_{\{a,b,d\}} + \delta_{\{a,b,c,d\}}) \\
 &\quad - (\delta_{\emptyset} - \delta_{\{a\}} - \delta_{\{b\}} + 2\delta_{\{a,b\}} - \delta_{\{a,b,c\}} - \delta_{\{a,b,d\}} + \delta_{\{a,b,c,d\}}) \\
 &= (\delta_{\emptyset} - \delta_{\{c\}} - \delta_{\{a,b,d\}} + \delta_{\{a,b,c,d\}}) \\
 &\quad - (\delta_{\emptyset} - \delta_{\{a\}} - \delta_{\{c\}} + \delta_{\{a,b\}} + \delta_{\{a,c\}} - \delta_{\{a,b,c\}} - \delta_{\{a,b,d\}} + \delta_{\{a,b,c,d\}}) \\
 &= (\delta_{\emptyset} - \delta_{\{b\}} - \delta_{\{a,c,d\}} + \delta_{\{a,b,c,d\}}) \\
 &\quad - (\delta_{\emptyset} - \delta_{\{a\}} - \delta_{\{b\}} + \delta_{\{a,b\}} + \delta_{\{a,c\}} - \delta_{\{a,b,c\}} - \delta_{\{a,c,d\}} + \delta_{\{a,b,c,d\}}) \\
 &= (\delta_{\{a\}} - \delta_{\{a,b\}} - \delta_{\{a,c\}} + \delta_{\{b,c\}} - \delta_{\{b,c,d\}} + \delta_{\{a,b,c,d\}}) \\
 &\quad - (\delta_{\{b,c\}} - \delta_{\{a,b,c\}} - \delta_{\{b,c,d\}} + \delta_{\{a,b,c,d\}}) \\
 &= (\delta_{\{a\}} - \delta_{\{a,b\}} - \delta_{\{a,c,d\}} + \delta_{\{a,b,c,d\}}) \\
 &\quad - (\delta_{\{a,c\}} - \delta_{\{a,b,c\}} - \delta_{\{a,c,d\}} + \delta_{\{a,b,c,d\}}) \\
 &= (\delta_{\emptyset} - \delta_{\{c\}} - \delta_{\{a,b\}} + \delta_{\{a,b,c\}}) \\
 &\quad - (\delta_{\emptyset} - \delta_{\{a\}} - \delta_{\{c\}} + \delta_{\{a,c\}}) \\
 &= (\delta_{\{a\}} - \delta_{\{a,b\}} - \delta_{\{a,c\}} + \delta_{\{a,b,c\}}) \\
 &\quad - ()
 \end{aligned}$$

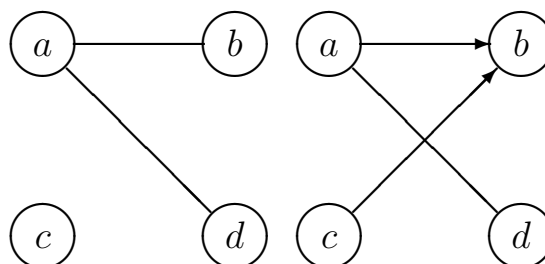
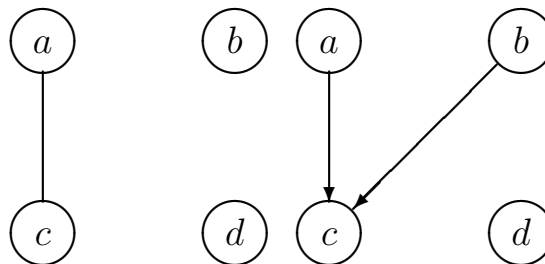
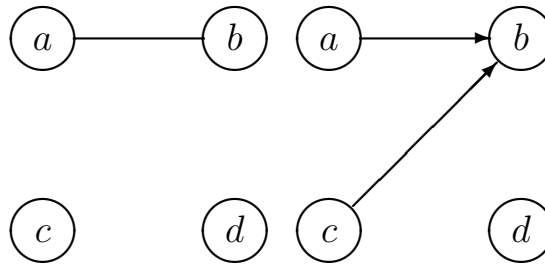

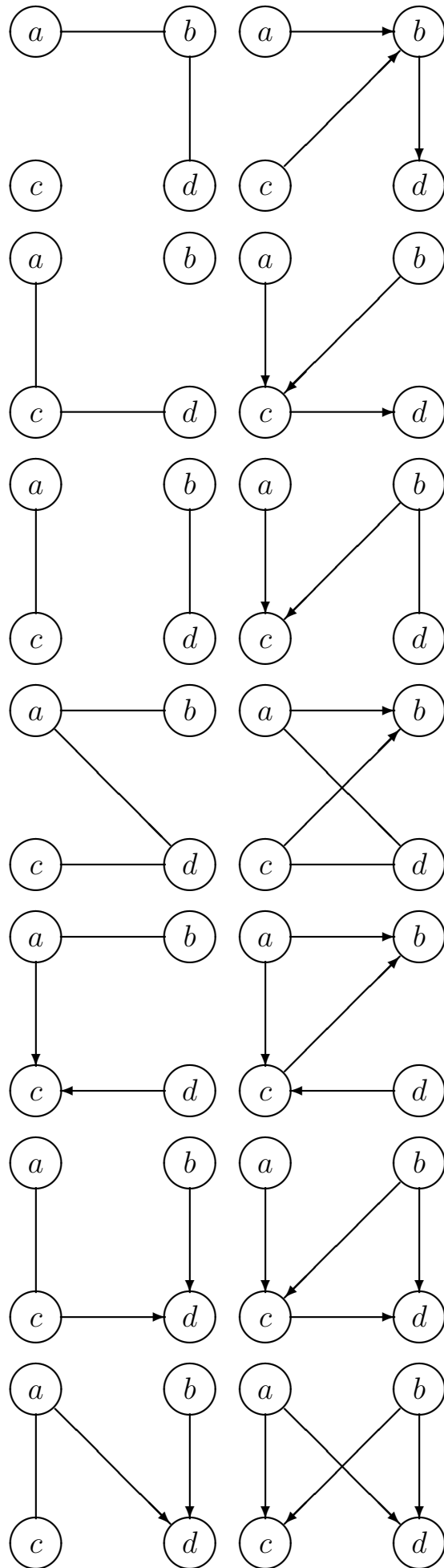

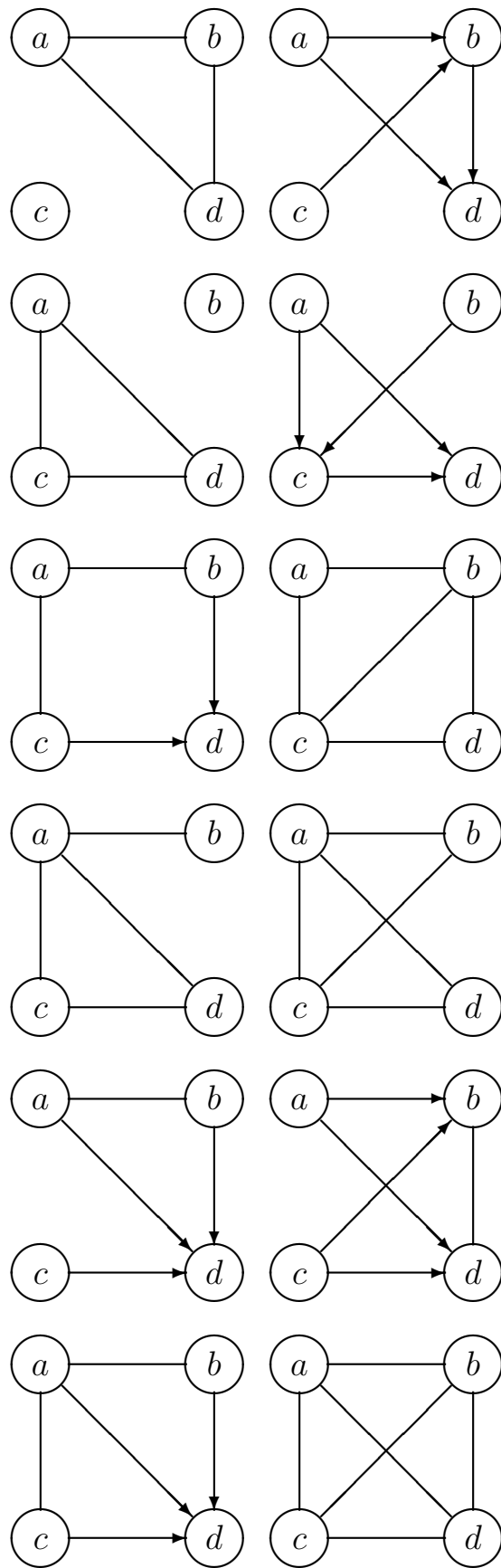



1.4.4.2 Differential inset (90)

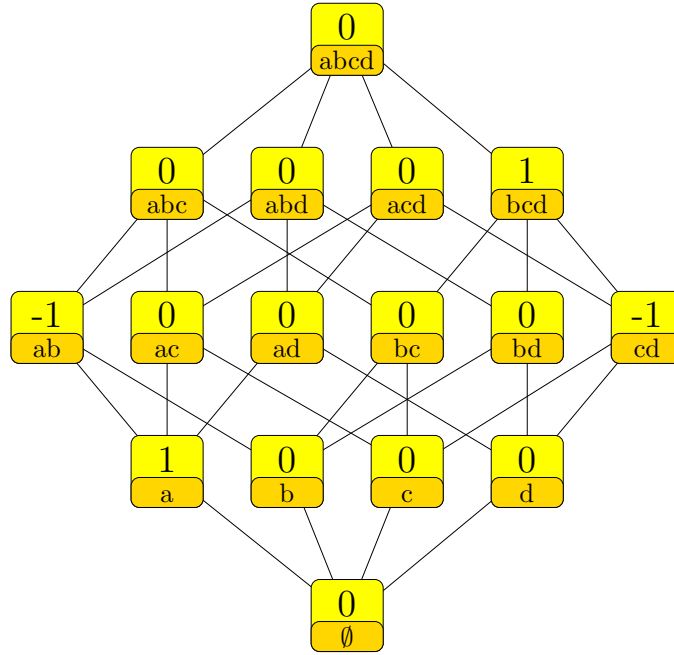

$$\begin{aligned}
 & \delta_{\{a\}} - \delta_{\{a,b\}} - \delta_{\{c,d\}} + \delta_{\{b,c,d\}} \\
 &= -u_{\langle a,b|\emptyset \rangle} + u_{\langle b,c|\emptyset \rangle} + u_{\langle b,d|c \rangle} \\
 &= (\delta_{\emptyset} - \delta_{\{a,b\}} - \delta_{\{c,d\}} + \delta_{\{a,b,c,d\}}) \\
 &\quad - (\delta_{\emptyset} - \delta_{\{a\}} - \delta_{\{b,c,d\}} + \delta_{\{a,b,c,d\}}) \\
 &= (\delta_{\emptyset} - \delta_{\{d\}} - \delta_{\{a,b\}} + \delta_{\{a,d\}} - \delta_{\{a,c,d\}} + \delta_{\{a,b,c,d\}}) \\
 &\quad - (\delta_{\emptyset} - \delta_{\{a\}} - \delta_{\{d\}} + \delta_{\{a,d\}} + \delta_{\{c,d\}} - \delta_{\{a,c,d\}} - \delta_{\{b,c,d\}} + \delta_{\{a,b,c,d\}}) \\
 &= (\delta_{\emptyset} - \delta_{\{b\}} + \delta_{\{b,c\}} - \delta_{\{c,d\}} - \delta_{\{a,b,c\}} + \delta_{\{a,b,c,d\}}) \\
 &\quad - (\delta_{\emptyset} - \delta_{\{a\}} - \delta_{\{b\}} + \delta_{\{a,b\}} + \delta_{\{b,c\}} - \delta_{\{a,b,c\}} - \delta_{\{b,c,d\}} + \delta_{\{a,b,c,d\}}) \\
 &= (\delta_{\{a\}} - \delta_{\{a,b\}} - \delta_{\{a,c,d\}} + \delta_{\{a,b,c,d\}}) \\
 &\quad - (\delta_{\{c,d\}} - \delta_{\{a,c,d\}} - \delta_{\{b,c,d\}} + \delta_{\{a,b,c,d\}})
 \end{aligned}$$

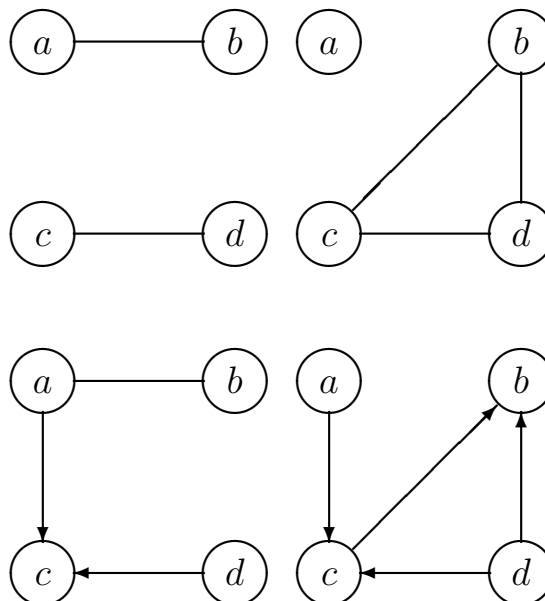

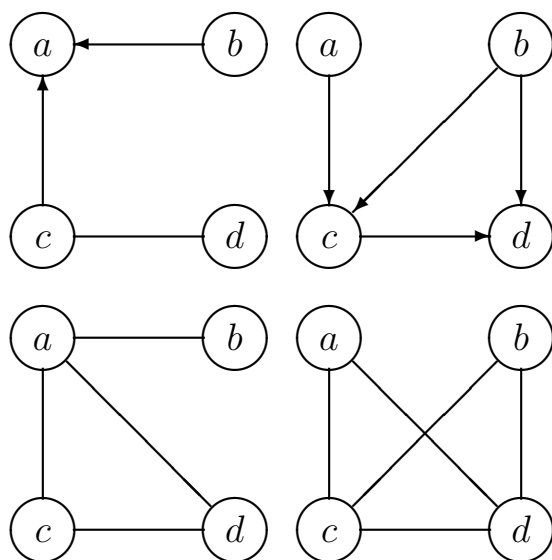

1.4.4.3 Differential inset (91)

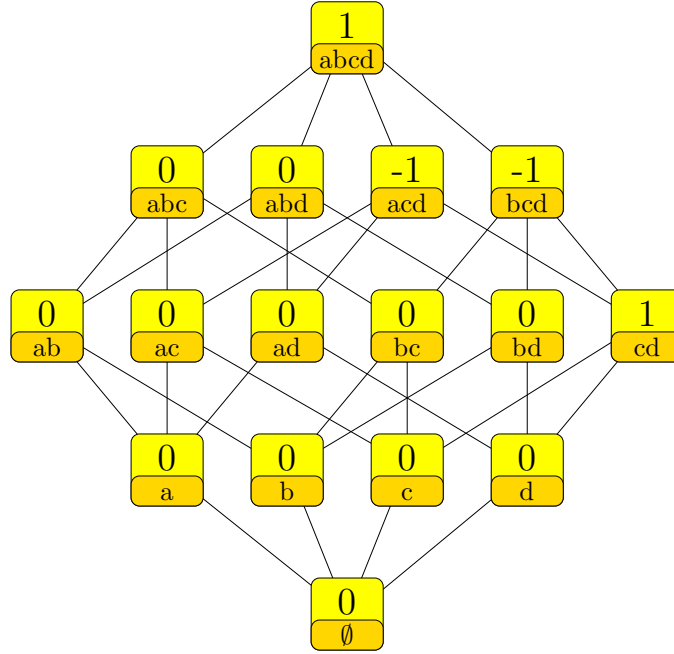

$$\begin{aligned}
 & \delta_{\{c,d\}} - \delta_{\{a,c,d\}} - \delta_{\{b,c,d\}} + \delta_{\{a,b,c,d\}} \\
 &= u_{\langle a,b|cd \rangle} \\
 &= (\delta_{\emptyset} - \delta_{\{c\}} - \delta_{\{a,d\}} + \delta_{\{c,d\}} - \delta_{\{b,c,d\}} + \delta_{\{a,b,c,d\}}) \\
 &\quad - (\delta_{\emptyset} - \delta_{\{c\}} - \delta_{\{a,d\}} + \delta_{\{a,c,d\}}) \\
 &= (\delta_{\emptyset} - \delta_{\{d\}} - \delta_{\{b,c\}} + \delta_{\{c,d\}} - \delta_{\{a,c,d\}} + \delta_{\{a,b,c,d\}}) \\
 &\quad - (\delta_{\emptyset} - \delta_{\{d\}} - \delta_{\{b,c\}} + \delta_{\{b,c,d\}}) \\
 &= (\delta_{\emptyset} - \delta_{\{c\}} - \delta_{\{b,d\}} + \delta_{\{c,d\}} - \delta_{\{a,c,d\}} + \delta_{\{a,b,c,d\}}) \\
 &\quad - (\delta_{\emptyset} - \delta_{\{c\}} - \delta_{\{b,d\}} + \delta_{\{b,c,d\}}) \\
 &= (\delta_{\emptyset} - \delta_{\{a\}} - \delta_{\{b,c,d\}} + \delta_{\{a,b,c,d\}}) \\
 &\quad - (\delta_{\emptyset} - \delta_{\{a\}} - \delta_{\{c,d\}} + \delta_{\{a,c,d\}}) \\
 &= (\delta_{\{a\}} - \delta_{\{a,c\}} - \delta_{\{a,d\}} + \delta_{\{c,d\}} - \delta_{\{b,c,d\}} + \delta_{\{a,b,c,d\}}) \\
 &\quad - (\delta_{\{a\}} - \delta_{\{a,c\}} - \delta_{\{a,d\}} + \delta_{\{a,c,d\}}) \\
 &= (\delta_{\{c\}} - \delta_{\{a,c\}} - \delta_{\{b,c,d\}} + \delta_{\{a,b,c,d\}}) \\
 &\quad - (\delta_{\{c\}} - \delta_{\{a,c\}} - \delta_{\{c,d\}} + \delta_{\{a,c,d\}}) \\
 &= (\delta_{\{d\}} - \delta_{\{a,d\}} - \delta_{\{b,c,d\}} + \delta_{\{a,b,c,d\}}) \\
 &\quad - (\delta_{\{d\}} - \delta_{\{a,d\}} - \delta_{\{c,d\}} + \delta_{\{a,c,d\}}) \\
 &= (\delta_{\{c\}} - \delta_{\{b,c\}} - \delta_{\{a,c,d\}} + \delta_{\{a,b,c,d\}}) \\
 &\quad - (\delta_{\{c\}} - \delta_{\{b,c\}} - \delta_{\{c,d\}} + \delta_{\{b,c,d\}}) \\
 &= (\delta_{\{c,d\}} - \delta_{\{a,c,d\}} - \delta_{\{b,c,d\}} + \delta_{\{a,b,c,d\}}) \\
 &\quad - ()
 \end{aligned}$$

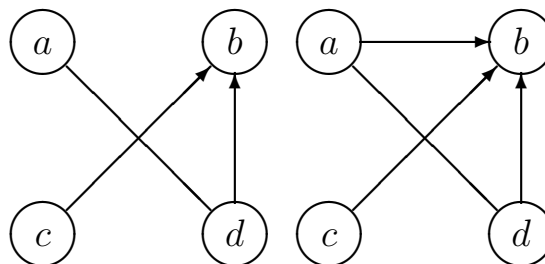

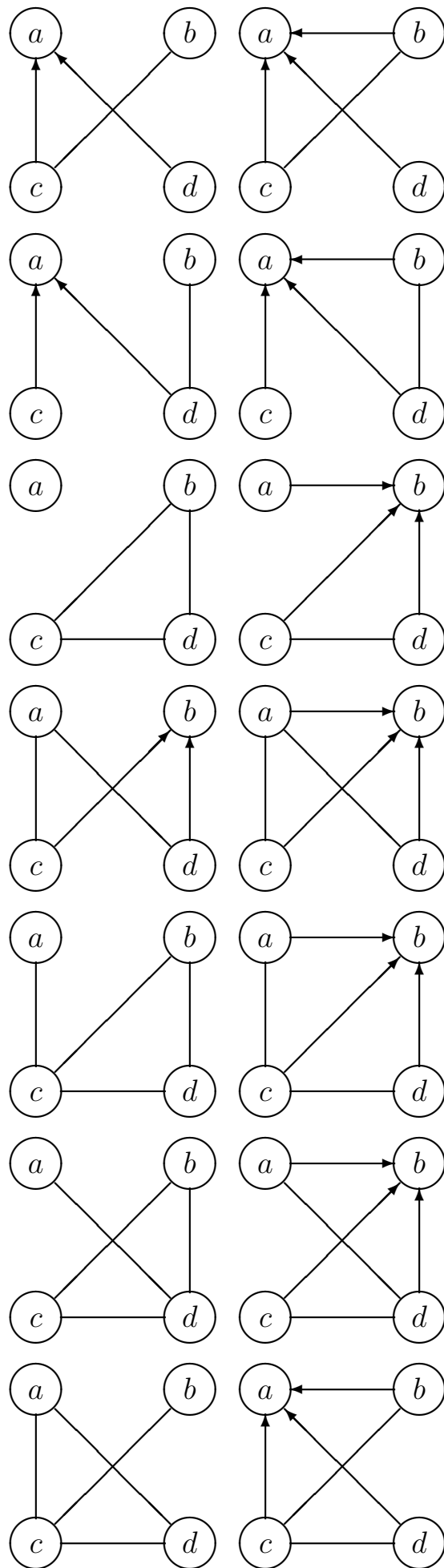

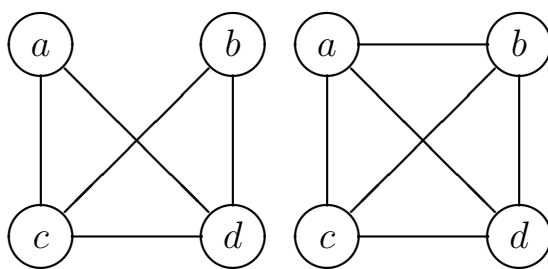

## 1.4.4.4 Differential inset (92)

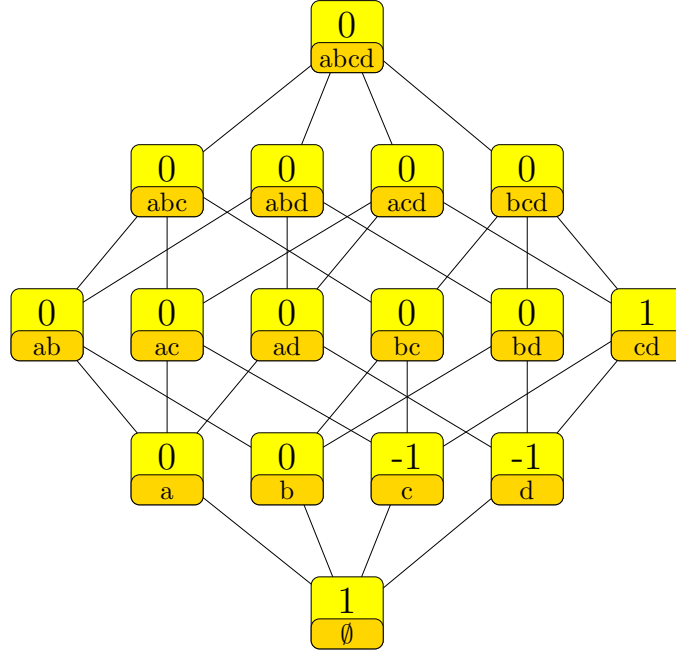

$$\begin{aligned}
& \delta_{\emptyset} - \delta_{\{c\}} - \delta_{\{d\}} + \delta_{\{c,d\}} \\
&= u_{\langle c,d|\emptyset \rangle} \\
&= (+3\delta_{\emptyset} - \delta_{\{a\}} - \delta_{\{b\}} - \delta_{\{c\}} - \delta_{\{d\}} + \delta_{\{a,b,c,d\}}) \\
&\quad - (+2\delta_{\emptyset} - \delta_{\{a\}} - \delta_{\{b\}} - \delta_{\{c,d\}} + \delta_{\{a,b,c,d\}}) \\
&= (\delta_{\emptyset} + \delta_{\{b\}} - \delta_{\{d\}} - \delta_{\{a,b\}} - \delta_{\{b,c\}} + \delta_{\{a,b,c,d\}}) \\
&\quad - (\delta_{\{b\}} + \delta_{\{c\}} - \delta_{\{a,b\}} - \delta_{\{b,c\}} - \delta_{\{c,d\}} + \delta_{\{a,b,c,d\}}) \\
&= (\delta_{\emptyset} - \delta_{\{a,c\}} - \delta_{\{b,d\}} + \delta_{\{a,b,c,d\}}) \\
&\quad - (\delta_{\{c\}} + \delta_{\{d\}} - \delta_{\{a,c\}} - \delta_{\{b,d\}} - \delta_{\{c,d\}} + \delta_{\{a,b,c,d\}}) \\
&= (+2\delta_{\emptyset} - \delta_{\{a\}} - \delta_{\{b\}} - \delta_{\{d\}} + \delta_{\{a,b\}} - \delta_{\{a,b,c\}} + \delta_{\{a,b,c,d\}}) \\
&\quad - (\delta_{\emptyset} - \delta_{\{a\}} - \delta_{\{b\}} + \delta_{\{c\}} + \delta_{\{a,b\}} - \delta_{\{c,d\}} - \delta_{\{a,b,c\}} + \delta_{\{a,b,c,d\}}) \\
&= (+2\delta_{\emptyset} - \delta_{\{a\}} - \delta_{\{b\}} - \delta_{\{c\}} + \delta_{\{a,b\}} - \delta_{\{a,b,d\}} + \delta_{\{a,b,c,d\}}) \\
&\quad - (\delta_{\emptyset} - \delta_{\{a\}} - \delta_{\{b\}} + \delta_{\{d\}} + \delta_{\{a,b\}} - \delta_{\{c,d\}} - \delta_{\{a,b,d\}} + \delta_{\{a,b,c,d\}}) \\
&= (\delta_{\emptyset} - \delta_{\{c\}} + \delta_{\{b,c\}} - \delta_{\{b,d\}} - \delta_{\{a,b,c\}} + \delta_{\{a,b,c,d\}}) \\
&\quad - (\delta_{\{d\}} + \delta_{\{b,c\}} - \delta_{\{b,d\}} - \delta_{\{c,d\}} - \delta_{\{a,b,c\}} + \delta_{\{a,b,c,d\}}) \\
&= (+2\delta_{\emptyset} - \delta_{\{a\}} - \delta_{\{c\}} - \delta_{\{d\}} + \delta_{\{a,c,d\}}) \\
&\quad - (\delta_{\emptyset} - \delta_{\{a\}} - \delta_{\{c,d\}} + \delta_{\{a,c,d\}}) \\
&= (\delta_{\emptyset} - \delta_{\{c\}} - \delta_{\{a,d\}} + \delta_{\{a,c,d\}}) \\
&\quad - (\delta_{\{d\}} - \delta_{\{a,d\}} - \delta_{\{c,d\}} + \delta_{\{a,c,d\}}) \\
&= (\delta_{\emptyset} - \delta_{\{c\}} - \delta_{\{b,d\}} + \delta_{\{b,c,d\}}) \\
&\quad - (\delta_{\{d\}} - \delta_{\{b,d\}} - \delta_{\{c,d\}} + \delta_{\{b,c,d\}}) \\
&= (\delta_{\emptyset} - \delta_{\{c\}} - \delta_{\{d\}} + \delta_{\{b,c\}} + \delta_{\{c,d\}} - \delta_{\{a,b,c\}} - \delta_{\{b,c,d\}} + \delta_{\{a,b,c,d\}}) \\
&\quad - (\delta_{\{b,c\}} - \delta_{\{a,b,c\}} - \delta_{\{b,c,d\}} + \delta_{\{a,b,c,d\}}) \\
&= (\delta_{\emptyset} - \delta_{\{c\}} - \delta_{\{d\}} + \delta_{\{a,d\}} + \delta_{\{c,d\}} - \delta_{\{a,b,d\}} - \delta_{\{a,c,d\}} + \delta_{\{a,b,c,d\}}) \\
&\quad - (\delta_{\{a,d\}} - \delta_{\{a,b,d\}} - \delta_{\{a,c,d\}} + \delta_{\{a,b,c,d\}}) \\
&= (\delta_{\emptyset} - \delta_{\{c\}} - \delta_{\{d\}} + \delta_{\{c,d\}}) \\
&\quad - ()
\end{aligned}$$

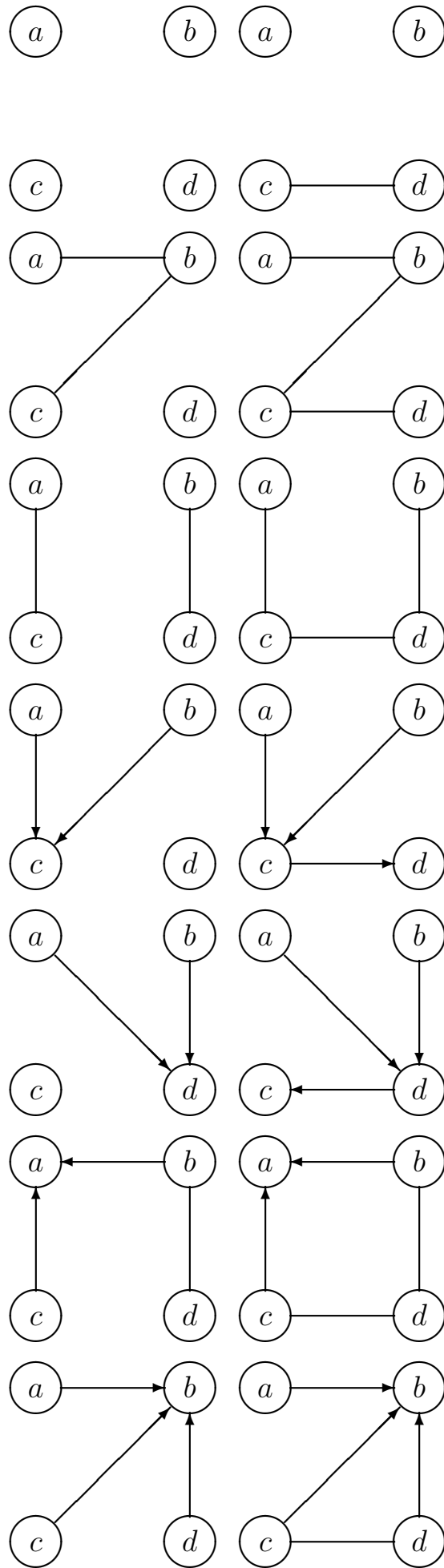

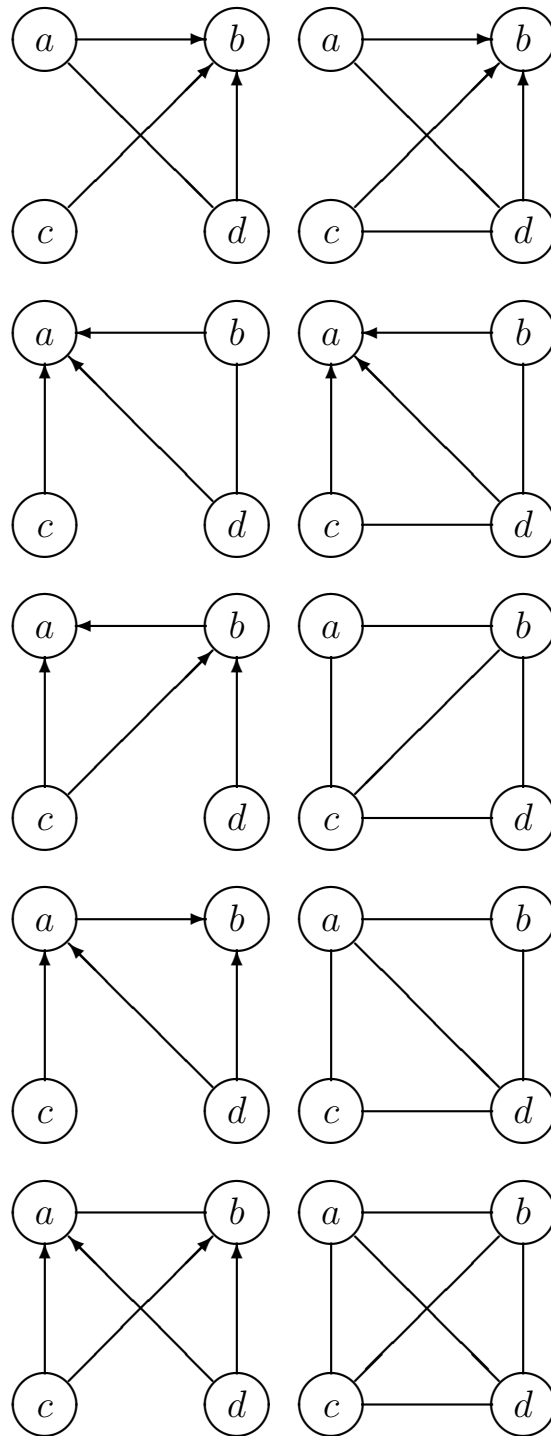



### 1.6 Squared Euclidean length 6

#### 1.6.6 Number of nonzero values 6

##### 1.6.6.1 Differential inset (93)

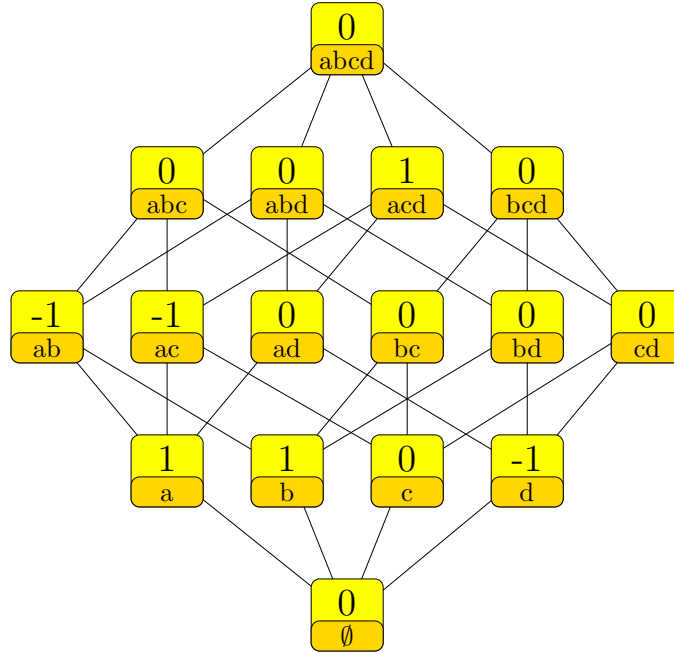

$$\begin{aligned}
 & \delta_{\{a\}} + \delta_{\{b\}} - \delta_{\{d\}} - \delta_{\{a,b\}} - \delta_{\{a,c\}} + \delta_{\{a,c,d\}} \\
 &= -u_{\langle a,b|\emptyset \rangle} + u_{\langle a,d|\emptyset \rangle} + u_{\langle c,d|a \rangle} \\
 &= (\delta_{\emptyset} + \delta_{\{b\}} - \delta_{\{c\}} - \delta_{\{a,b\}} - \delta_{\{b,d\}} + \delta_{\{a,b,c,d\}}) \\
 &\quad - (\delta_{\emptyset} - \delta_{\{a\}} - \delta_{\{c\}} + \delta_{\{d\}} + \delta_{\{a,c\}} - \delta_{\{b,d\}} - \delta_{\{a,c,d\}} + \delta_{\{a,b,c,d\}}) \\
 &= (\delta_{\emptyset} - \delta_{\{d\}} - \delta_{\{a,b,c\}} + \delta_{\{a,b,c,d\}}) \\
 &\quad - (\delta_{\emptyset} - \delta_{\{a\}} - \delta_{\{b\}} + \delta_{\{a,b\}} + \delta_{\{a,c\}} - \delta_{\{a,b,c\}} - \delta_{\{a,c,d\}} + \delta_{\{a,b,c,d\}})
 \end{aligned}$$

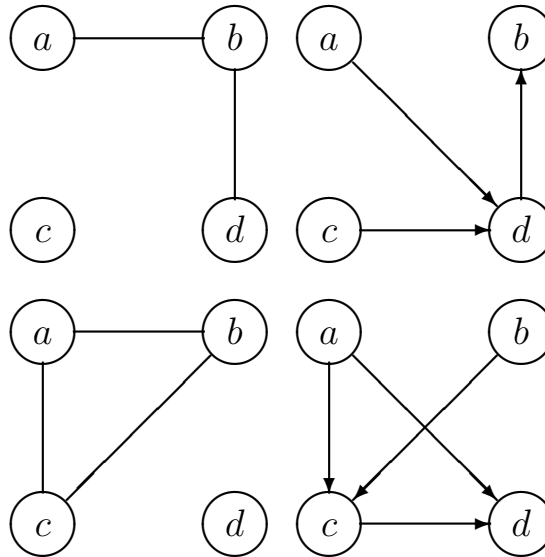

1.6.6.2 Differential imset (94)

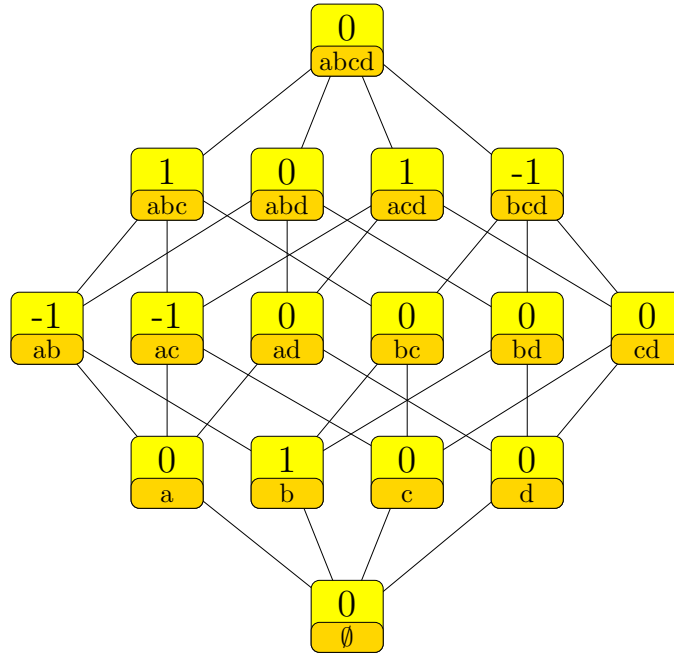

$$\begin{aligned}
 & \delta_{\{b\}} - \delta_{\{a,b\}} - \delta_{\{a,c\}} + \delta_{\{a,b,c\}} + \delta_{\{a,c,d\}} - \delta_{\{b,c,d\}} \\
 &= -u_{\langle b,d|ac \rangle} + u_{\langle a,d|bc \rangle} + u_{\langle a,c|b \rangle} \\
 &= (\delta_{\emptyset} - \delta_{\{c\}} - \delta_{\{a,b\}} + \delta_{\{b,c\}} - \delta_{\{b,c,d\}} + \delta_{\{a,b,c,d\}}) \\
 &\quad - (\delta_{\emptyset} - \delta_{\{b\}} - \delta_{\{c\}} + \delta_{\{a,c\}} + \delta_{\{b,c\}} - \delta_{\{a,b,c\}} - \delta_{\{a,c,d\}} + \delta_{\{a,b,c,d\}})
 \end{aligned}$$

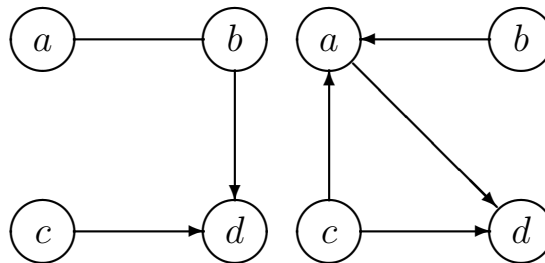

1.6.6.3 Differential inset (95)

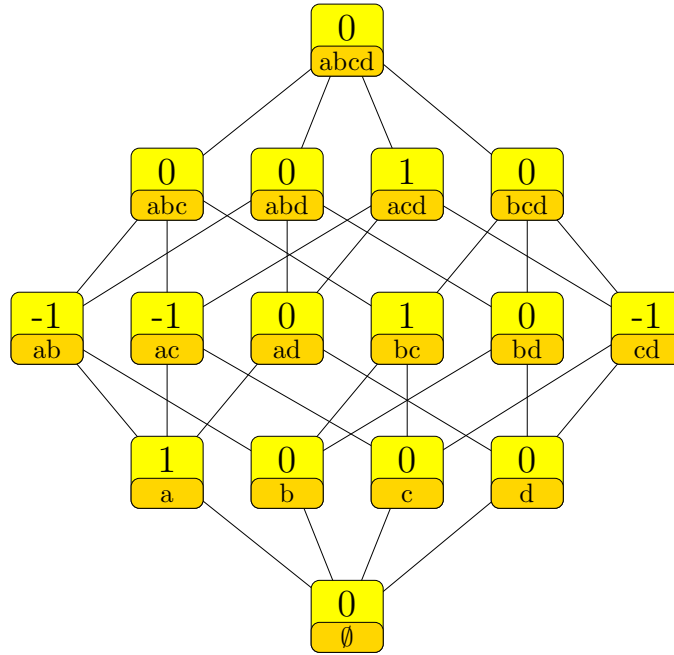

$$\begin{aligned}
 & \delta_{\{a\}} - \delta_{\{a,b\}} - \delta_{\{a,c\}} + \delta_{\{b,c\}} - \delta_{\{c,d\}} + \delta_{\{a,c,d\}} \\
 &= -u_{\langle a,b|\emptyset \rangle} + u_{\langle b,c|\emptyset \rangle} + u_{\langle a,d|c \rangle} \\
 &= (\delta_{\emptyset} - \delta_{\{a,b\}} - \delta_{\{c,d\}} + \delta_{\{a,b,c,d\}}) \\
 &\quad - (\delta_{\emptyset} - \delta_{\{a\}} + \delta_{\{a,c\}} - \delta_{\{b,c\}} - \delta_{\{a,c,d\}} + \delta_{\{a,b,c,d\}}) \\
 &= (\delta_{\emptyset} - \delta_{\{b\}} + \delta_{\{b,c\}} - \delta_{\{c,d\}} - \delta_{\{a,b,c\}} + \delta_{\{a,b,c,d\}}) \\
 &\quad - (\delta_{\emptyset} - \delta_{\{a\}} - \delta_{\{b\}} + \delta_{\{a,b\}} + \delta_{\{a,c\}} - \delta_{\{a,b,c\}} - \delta_{\{a,c,d\}} + \delta_{\{a,b,c,d\}})
 \end{aligned}$$

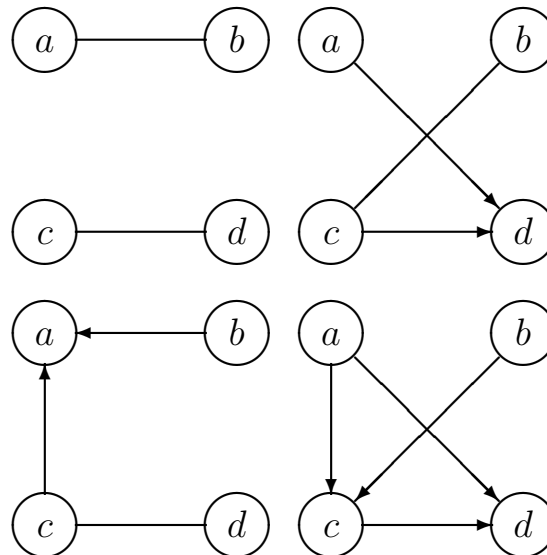

1.6.6.4 Differential inset (96)

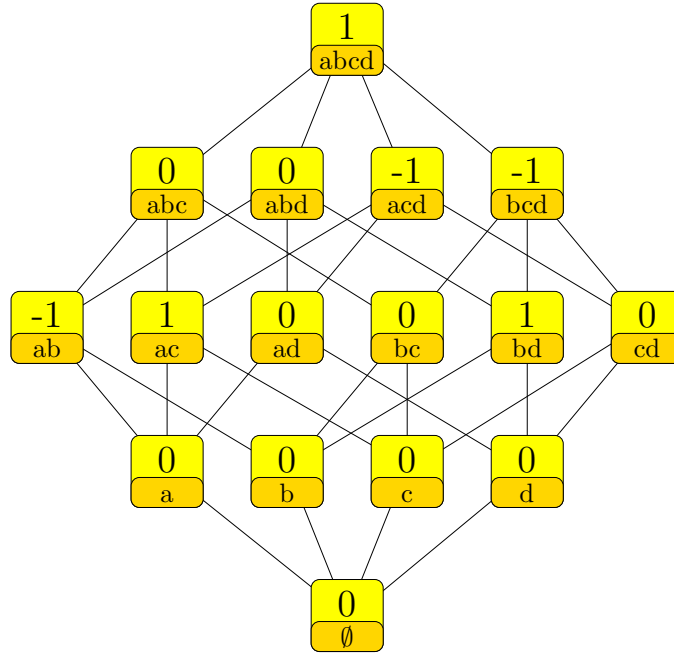

$$\begin{aligned}
 & -\delta_{\{a,b\}} + \delta_{\{a,c\}} + \delta_{\{b,d\}} - \delta_{\{a,c,d\}} - \delta_{\{b,c,d\}} + \delta_{\{a,b,c,d\}} \\
 &= u_{\langle a,c|bd \rangle} + u_{\langle b,d|a \rangle} - u_{\langle c,d|a \rangle} \\
 &= (\delta_{\emptyset} - \delta_{\{d\}} - \delta_{\{a,b\}} + \delta_{\{b,d\}} - \delta_{\{b,c,d\}} + \delta_{\{a,b,c,d\}}) \\
 &\quad - (\delta_{\emptyset} - \delta_{\{d\}} - \delta_{\{a,c\}} + \delta_{\{a,c,d\}}) \\
 &= (\delta_{\emptyset} - \delta_{\{c\}} - \delta_{\{a,b\}} + \delta_{\{a,c\}} - \delta_{\{a,c,d\}} + \delta_{\{a,b,c,d\}}) \\
 &\quad - (\delta_{\emptyset} - \delta_{\{c\}} - \delta_{\{b,d\}} + \delta_{\{b,c,d\}}) \\
 &= (\delta_{\{a\}} - \delta_{\{a,b\}} - \delta_{\{a,d\}} + \delta_{\{b,d\}} - \delta_{\{b,c,d\}} + \delta_{\{a,b,c,d\}}) \\
 &\quad - (\delta_{\{a\}} - \delta_{\{a,c\}} - \delta_{\{a,d\}} + \delta_{\{a,c,d\}}) \\
 &= (\delta_{\{b\}} - \delta_{\{a,b\}} + \delta_{\{a,c\}} - \delta_{\{b,c\}} - \delta_{\{a,c,d\}} + \delta_{\{a,b,c,d\}}) \\
 &\quad - (\delta_{\{b\}} - \delta_{\{b,c\}} - \delta_{\{b,d\}} + \delta_{\{b,c,d\}})
 \end{aligned}$$

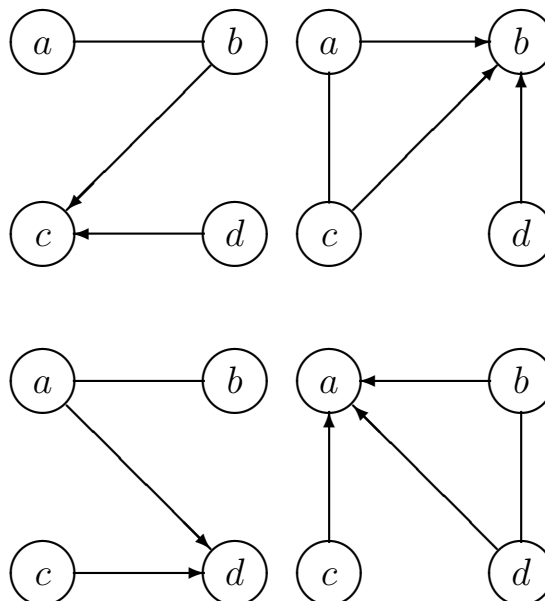

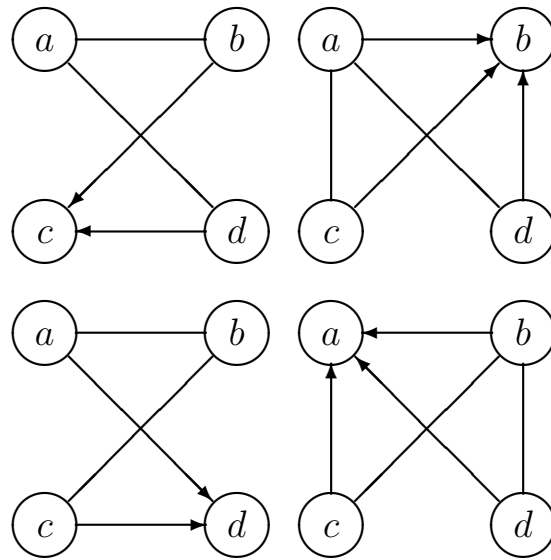

1.6.6.5 Differential inset (97)

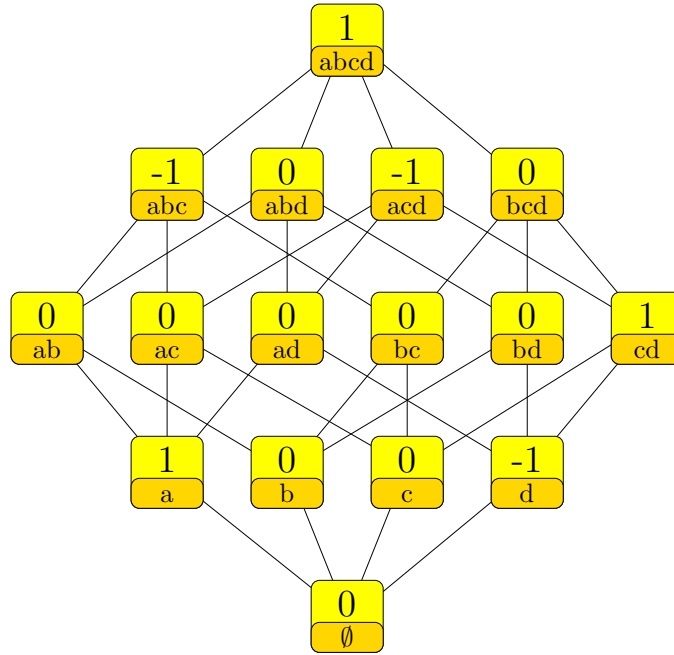

$$\begin{aligned}
 & \delta_{\{a\}} - \delta_{\{d\}} + \delta_{\{c,d\}} - \delta_{\{a,b,c\}} - \delta_{\{a,c,d\}} + \delta_{\{a,b,c,d\}} \\
 &= -u_{\langle a,c|\emptyset \rangle} + u_{\langle c,d|\emptyset \rangle} + u_{\langle b,d|ac \rangle} \\
 &= (+2\delta_{\emptyset} - \delta_{\{b\}} - \delta_{\{c\}} - \delta_{\{d\}} + \delta_{\{c,d\}} - \delta_{\{a,c,d\}} + \delta_{\{a,b,c,d\}}) \\
 &\quad - (+2\delta_{\emptyset} - \delta_{\{a\}} - \delta_{\{b\}} - \delta_{\{c\}} + \delta_{\{a,b,c\}}) \\
 &= (\delta_{\emptyset} - \delta_{\{a\}} - \delta_{\{b,c\}} + \delta_{\{c,d\}} - \delta_{\{a,c,d\}} + \delta_{\{a,b,c,d\}}) \\
 &\quad - (\delta_{\emptyset} - \delta_{\{a\}} - \delta_{\{b,c\}} + \delta_{\{a,b,c\}})
 \end{aligned}$$

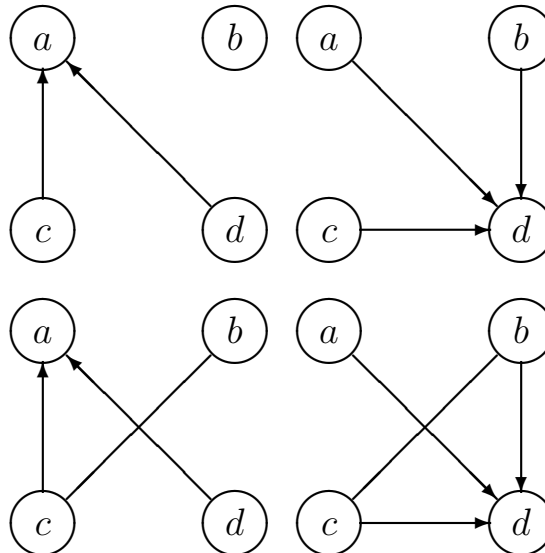

1.6.6.6 Differential inset (98)

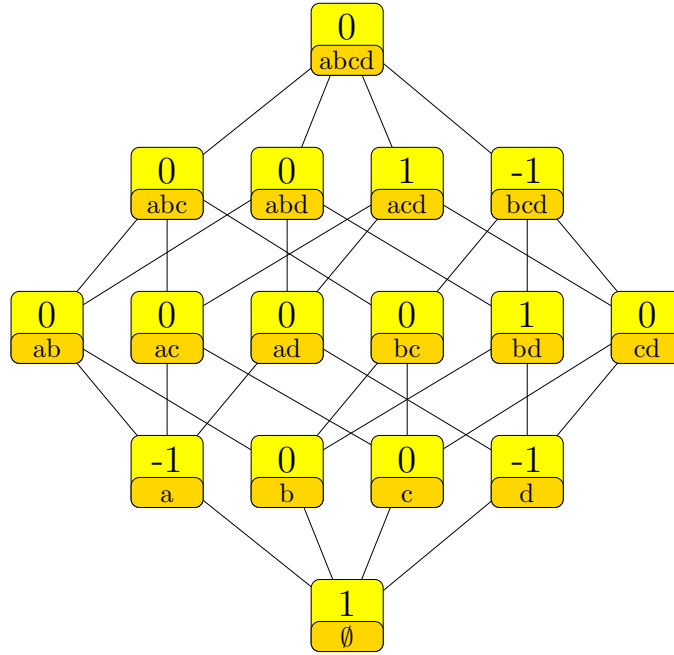

$$\begin{aligned}
 & \delta_\emptyset - \delta_{\{a\}} - \delta_{\{d\}} + \delta_{\{b,d\}} + \delta_{\{a,c,d\}} - \delta_{\{b,c,d\}} \\
 &= u_{\langle a,d|\emptyset \rangle} - u_{\langle b,c|ad \rangle} + u_{\langle a,c|bd \rangle} \\
 &= (+2\delta_\emptyset - \delta_{\{a\}} - \delta_{\{c\}} - \delta_{\{d\}} + \delta_{\{c,d\}} - \delta_{\{b,c,d\}} + \delta_{\{a,b,c,d\}}) \\
 &\quad - (\delta_\emptyset - \delta_{\{c\}} - \delta_{\{b,d\}} + \delta_{\{c,d\}} - \delta_{\{a,c,d\}} + \delta_{\{a,b,c,d\}}) \\
 &= (+2\delta_\emptyset - \delta_{\{a\}} - \delta_{\{c\}} - \delta_{\{d\}} + \delta_{\{a,c,d\}}) \\
 &\quad - (\delta_\emptyset - \delta_{\{c\}} - \delta_{\{b,d\}} + \delta_{\{b,c,d\}}) \\
 &= (\delta_\emptyset - \delta_{\{a\}} - \delta_{\{c,d\}} + \delta_{\{a,c,d\}}) \\
 &\quad - (\delta_{\{d\}} - \delta_{\{b,d\}} - \delta_{\{c,d\}} + \delta_{\{b,c,d\}}) \\
 &= (\delta_\emptyset - \delta_{\{a\}} - \delta_{\{d\}} + \delta_{\{a,d\}} + \delta_{\{b,d\}} - \delta_{\{a,b,d\}} - \delta_{\{b,c,d\}} + \delta_{\{a,b,c,d\}}) \\
 &\quad - (\delta_{\{a,d\}} - \delta_{\{a,b,d\}} - \delta_{\{a,c,d\}} + \delta_{\{a,b,c,d\}})
 \end{aligned}$$

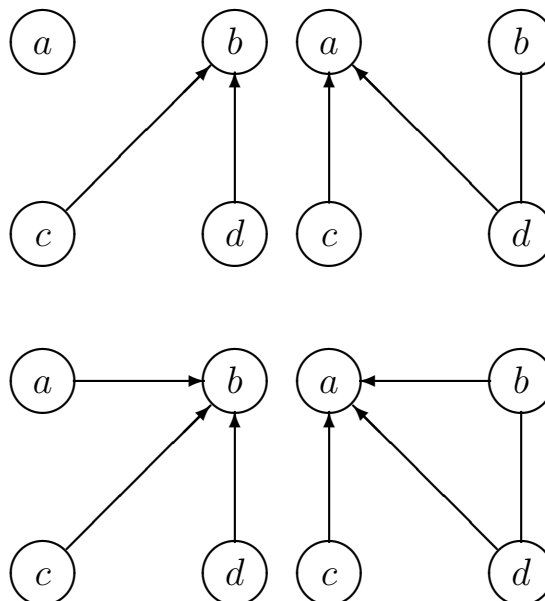

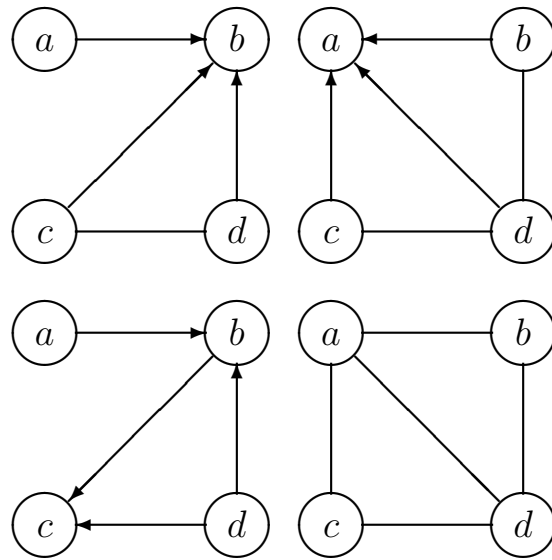



1.6.6.7 Differential imset (99)

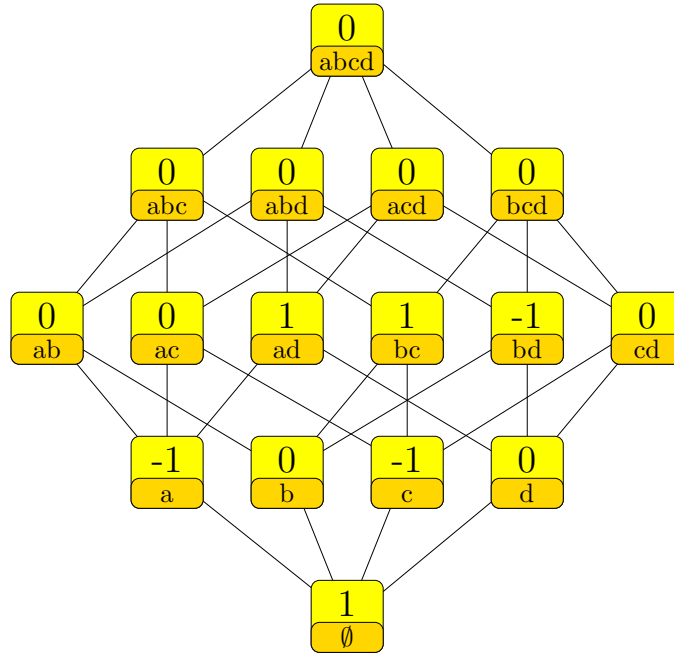

$$\begin{aligned}
 & \delta_\emptyset - \delta_{\{a\}} - \delta_{\{c\}} + \delta_{\{a,d\}} + \delta_{\{b,c\}} - \delta_{\{b,d\}} \\
 &= u_{\langle a,d|\emptyset \rangle} + u_{\langle b,c|\emptyset \rangle} - u_{\langle b,d|\emptyset \rangle} \\
 &= (+2\delta_\emptyset - \delta_{\{a\}} - \delta_{\{c\}} - \delta_{\{b,d\}} + \delta_{\{a,b,c,d\}}) \\
 &\quad - (\delta_\emptyset - \delta_{\{a,d\}} - \delta_{\{b,c\}} + \delta_{\{a,b,c,d\}})
 \end{aligned}$$

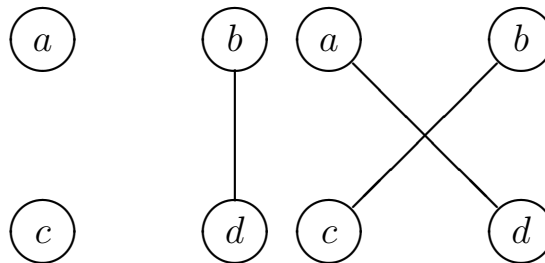

### 1.8 Squared Euclidean length 8

#### 1.8.5 Number of nonzero values 5

##### 1.8.5.1 Differential imset (100)

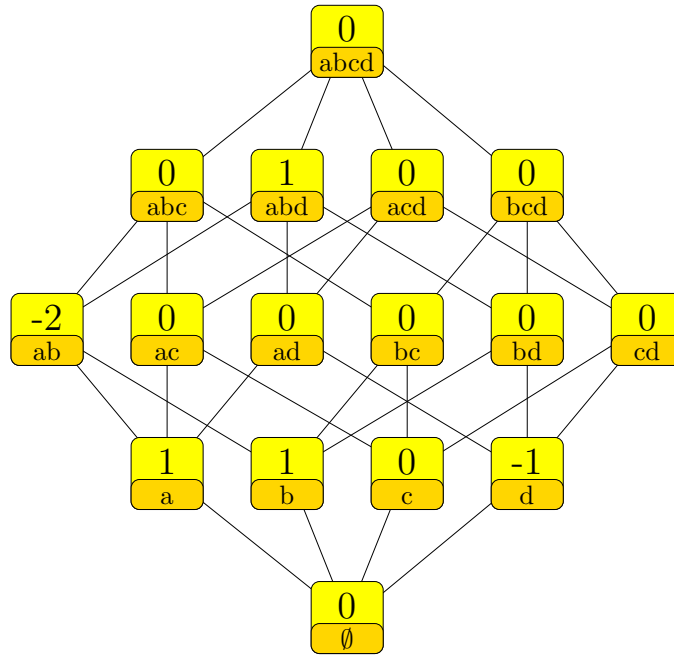

$$\begin{aligned}
 & \delta_{\{a\}} + \delta_{\{b\}} - \delta_{\{d\}} - 2\delta_{\{a,b\}} + \delta_{\{a,b,d\}} \\
 &= -u_{\langle a,b|\emptyset \rangle} + u_{\langle a,d|\emptyset \rangle} + u_{\langle b,d|a \rangle} \\
 &= (\delta_{\emptyset} + \delta_{\{b\}} - \delta_{\{d\}} - \delta_{\{a,b\}} - \delta_{\{b,c\}} + \delta_{\{a,b,c,d\}}) \\
 &\quad - (\delta_{\emptyset} - \delta_{\{a\}} + \delta_{\{a,b\}} - \delta_{\{b,c\}} - \delta_{\{a,b,d\}} + \delta_{\{a,b,c,d\}}) \\
 &= (\delta_{\emptyset} - \delta_{\{d\}} - \delta_{\{a,b\}} + \delta_{\{b,d\}} - \delta_{\{b,c,d\}} + \delta_{\{a,b,c,d\}}) \\
 &\quad - (\delta_{\emptyset} - \delta_{\{a\}} - \delta_{\{b\}} + \delta_{\{a,b\}} + \delta_{\{b,d\}} - \delta_{\{a,b,d\}} - \delta_{\{b,c,d\}} + \delta_{\{a,b,c,d\}}) \\
 &= (\delta_{\emptyset} - \delta_{\{d\}} - \delta_{\{a,b,c\}} + \delta_{\{a,b,c,d\}}) \\
 &\quad - (\delta_{\emptyset} - \delta_{\{a\}} - \delta_{\{b\}} + 2\delta_{\{a,b\}} - \delta_{\{a,b,c\}} - \delta_{\{a,b,d\}} + \delta_{\{a,b,c,d\}}) \\
 &= (\delta_{\emptyset} - \delta_{\{d\}} - \delta_{\{a,b\}} + \delta_{\{a,b,d\}}) \\
 &\quad - (\delta_{\emptyset} - \delta_{\{a\}} - \delta_{\{b\}} + \delta_{\{a,b\}})
 \end{aligned}$$

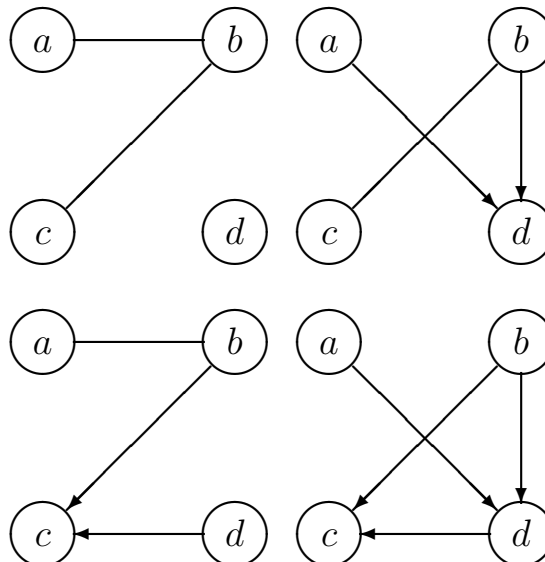

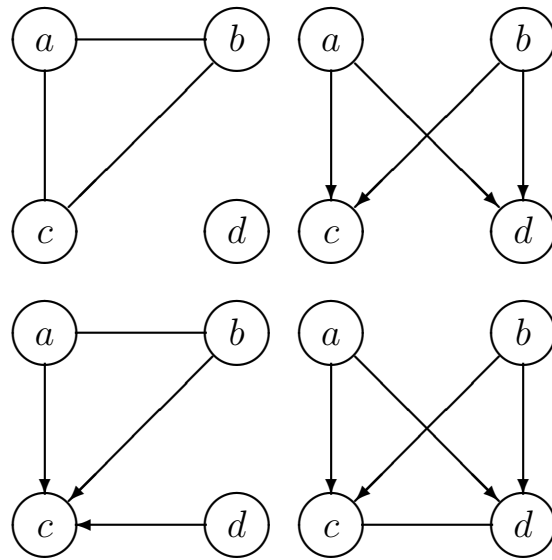

1.8.5.2 Differential inset (101)

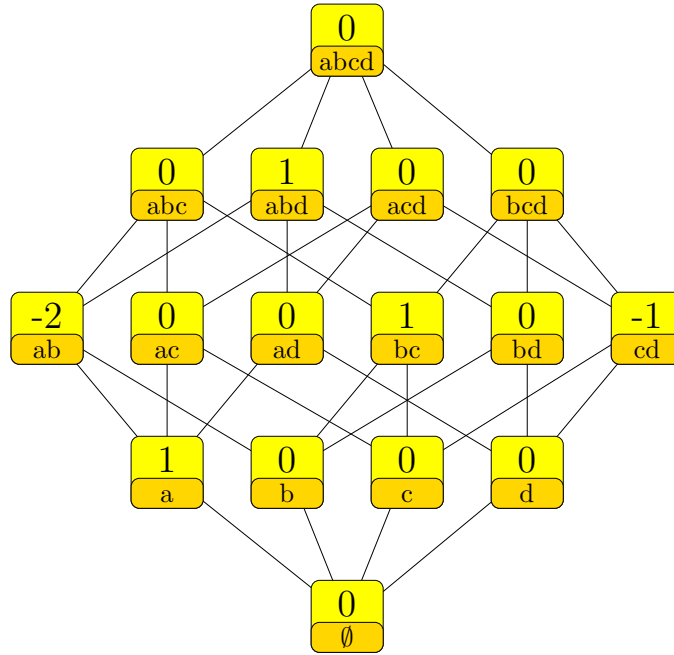

$$\begin{aligned}
 & \delta_{\{a\}} - 2\delta_{\{a,b\}} + \delta_{\{b,c\}} - \delta_{\{c,d\}} + \delta_{\{a,b,d\}} \\
 &= -u_{\langle a,b|\emptyset \rangle} + u_{\langle a,d|\emptyset \rangle} + u_{\langle b,c|\emptyset \rangle} - u_{\langle c,d|\emptyset \rangle} + u_{\langle b,d|a \rangle} \\
 &= (\delta_{\emptyset} - \delta_{\{a,b\}} - \delta_{\{c,d\}} + \delta_{\{a,b,c,d\}}) \\
 &\quad - (\delta_{\emptyset} - \delta_{\{a\}} + \delta_{\{a,b\}} - \delta_{\{b,c\}} - \delta_{\{a,b,d\}} + \delta_{\{a,b,c,d\}}) \\
 &= (\delta_{\{a\}} + \delta_{\{c\}} - \delta_{\{a,b\}} - \delta_{\{a,c\}} - \delta_{\{c,d\}} + \delta_{\{a,b,c,d\}}) \\
 &\quad - (\delta_{\{c\}} + \delta_{\{a,b\}} - \delta_{\{a,c\}} - \delta_{\{b,c\}} - \delta_{\{a,b,d\}} + \delta_{\{a,b,c,d\}})
 \end{aligned}$$

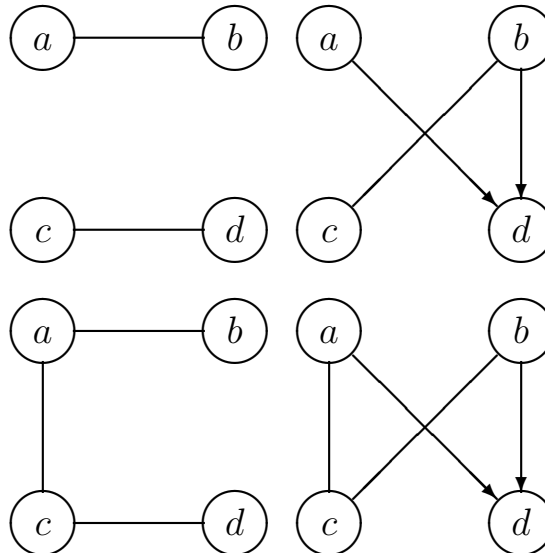

1.8.5.3 Differential inset (102)

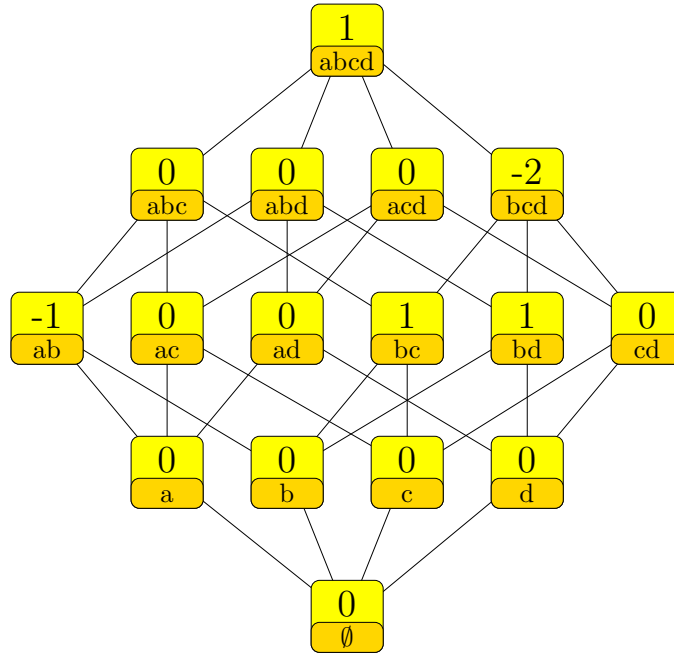

$$\begin{aligned}
 & -\delta_{\{a,b\}} + \delta_{\{b,c\}} + \delta_{\{b,d\}} - 2\delta_{\{b,c,d\}} + \delta_{\{a,b,c,d\}} \\
 &= -u_{\langle c,d|ab \rangle} + u_{\langle a,d|bc \rangle} + u_{\langle a,c|bd \rangle} \\
 &= (\delta_\emptyset - \delta_{\{c\}} - \delta_{\{a,b\}} + \delta_{\{b,c\}} - \delta_{\{b,c,d\}} + \delta_{\{a,b,c,d\}}) \\
 &\quad - (\delta_\emptyset - \delta_{\{c\}} - \delta_{\{b,d\}} + \delta_{\{b,c,d\}})
 \end{aligned}$$

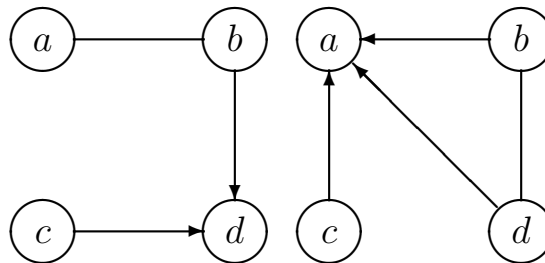

1.8.5.4 Differential inset (103)

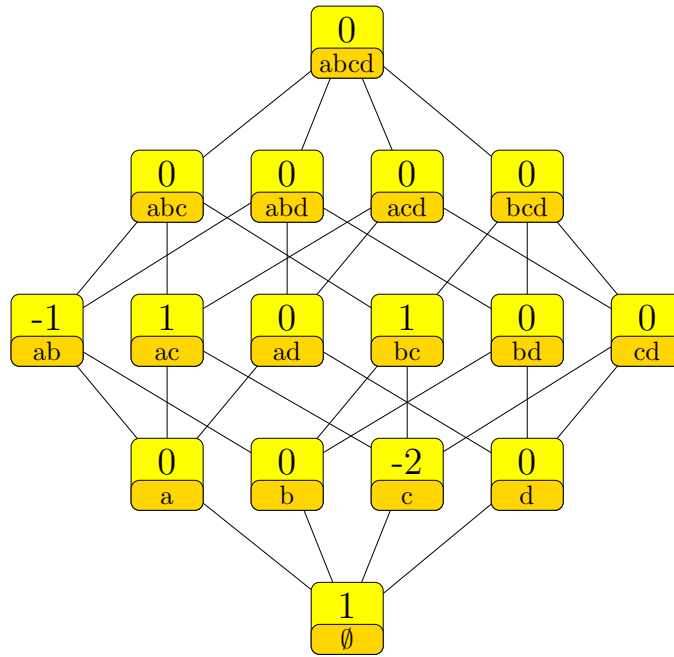

$$\begin{aligned}
 \delta_{\emptyset} - 2\delta_{\{c\}} - \delta_{\{a,b\}} + \delta_{\{a,c\}} + \delta_{\{b,c\}} &= u_{\langle a,c|\emptyset \rangle} + u_{\langle b,c|a \rangle} - u_{\langle a,b|c \rangle} \\
 &= (+2\delta_{\emptyset} - \delta_{\{c\}} - \delta_{\{d\}} - \delta_{\{a,b\}} + \delta_{\{a,b,c,d\}}) \\
 &\quad - (\delta_{\emptyset} + \delta_{\{c\}} - \delta_{\{d\}} - \delta_{\{a,c\}} - \delta_{\{b,c\}} + \delta_{\{a,b,c,d\}})
 \end{aligned}$$

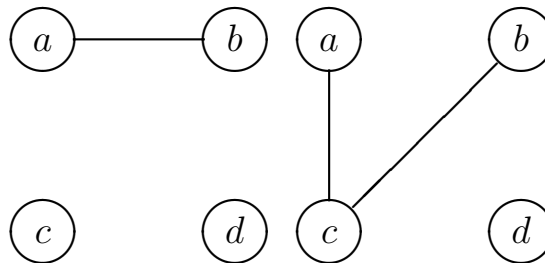

1.8.5.5 Differential inset (104)

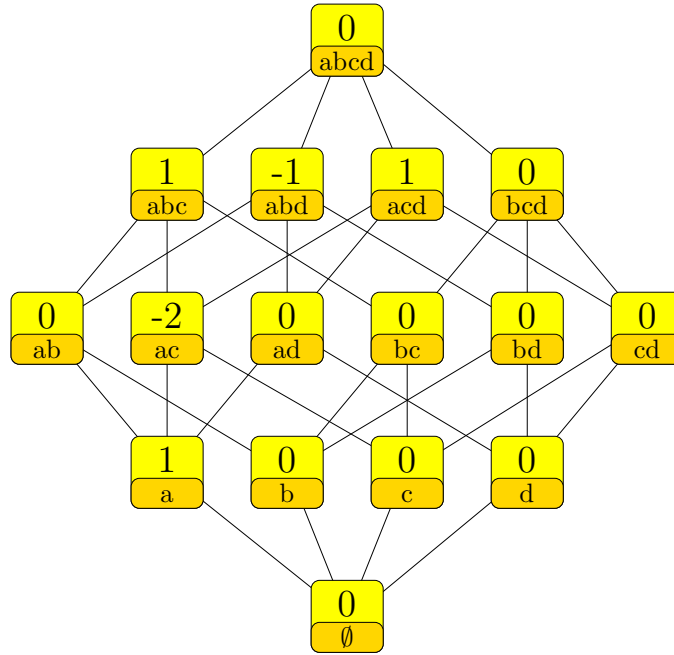

$$\begin{aligned}
 & \delta_{\{a\}} - 2\delta_{\{a,c\}} + \delta_{\{a,b,c\}} - \delta_{\{a,b,d\}} + \delta_{\{a,c,d\}} \\
 &= u_{\langle c,d|ab \rangle} - u_{\langle b,d|ac \rangle} + u_{\langle b,c|a \rangle} \\
 &= (\delta_{\emptyset} - \delta_{\{b\}} + \delta_{\{a,b\}} - \delta_{\{a,c\}} - \delta_{\{a,b,d\}} + \delta_{\{a,b,c,d\}}) \\
 &\quad - (\delta_{\emptyset} - \delta_{\{a\}} - \delta_{\{b\}} + \delta_{\{a,b\}} + \delta_{\{a,c\}} - \delta_{\{a,b,c\}} - \delta_{\{a,c,d\}} + \delta_{\{a,b,c,d\}}) \\
 &= (\delta_{\{a\}} - \delta_{\{a,c\}} - \delta_{\{a,b,d\}} + \delta_{\{a,b,c,d\}}) \\
 &\quad - (\delta_{\{a,c\}} - \delta_{\{a,b,c\}} - \delta_{\{a,c,d\}} + \delta_{\{a,b,c,d\}})
 \end{aligned}$$

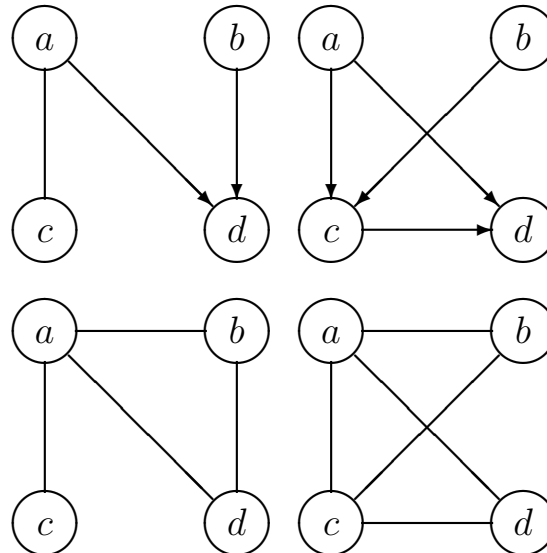

1.8.5.6 Differential inset (105)

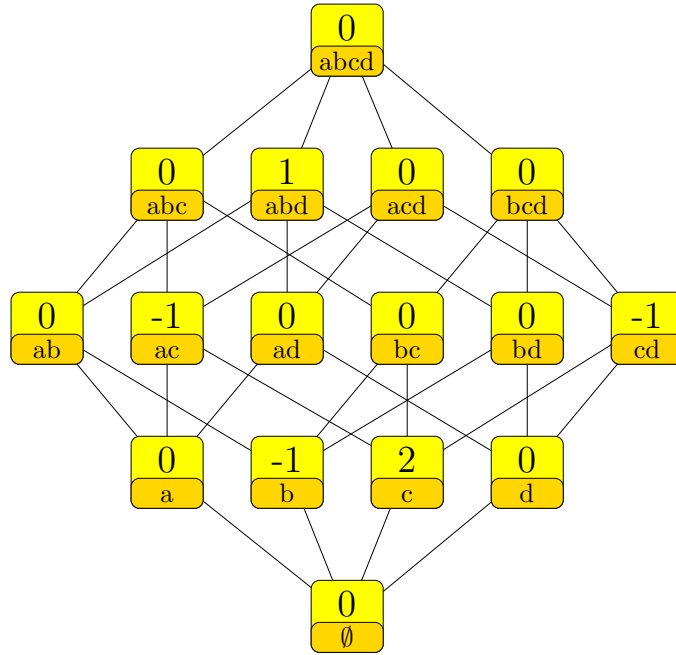

$$\begin{aligned}
 & -\delta_{\{b\}} + 2\delta_{\{c\}} - \delta_{\{a,c\}} - \delta_{\{c,d\}} + \delta_{\{a,b,d\}} \\
 &= u_{\langle a,b|\emptyset \rangle} - u_{\langle a,c|\emptyset \rangle} - u_{\langle c,d|ab \rangle} + u_{\langle b,d|ac \rangle} + u_{\langle a,d|c \rangle} \\
 &= (\delta_{\emptyset} - \delta_{\{b\}} + \delta_{\{c\}} - \delta_{\{a,c\}} - \delta_{\{c,d\}} + \delta_{\{a,b,c,d\}}) \\
 &\quad - (\delta_{\emptyset} - \delta_{\{c\}} - \delta_{\{a,b,d\}} + \delta_{\{a,b,c,d\}}) \\
 &= (+2\delta_{\{c\}} - \delta_{\{a,c\}} - \delta_{\{b,c\}} - \delta_{\{c,d\}} + \delta_{\{a,b,c,d\}}) \\
 &\quad - (\delta_{\{b\}} - \delta_{\{b,c\}} - \delta_{\{a,b,d\}} + \delta_{\{a,b,c,d\}}) \\
 &= (\delta_{\emptyset} - \delta_{\{b\}} + \delta_{\{c\}} - \delta_{\{d\}} - \delta_{\{a,c\}} + \delta_{\{b,d\}} - \delta_{\{b,c,d\}} + \delta_{\{a,b,c,d\}}) \\
 &\quad - (\delta_{\emptyset} - \delta_{\{c\}} - \delta_{\{d\}} + \delta_{\{b,d\}} + \delta_{\{c,d\}} - \delta_{\{a,b,d\}} - \delta_{\{b,c,d\}} + \delta_{\{a,b,c,d\}})
 \end{aligned}$$

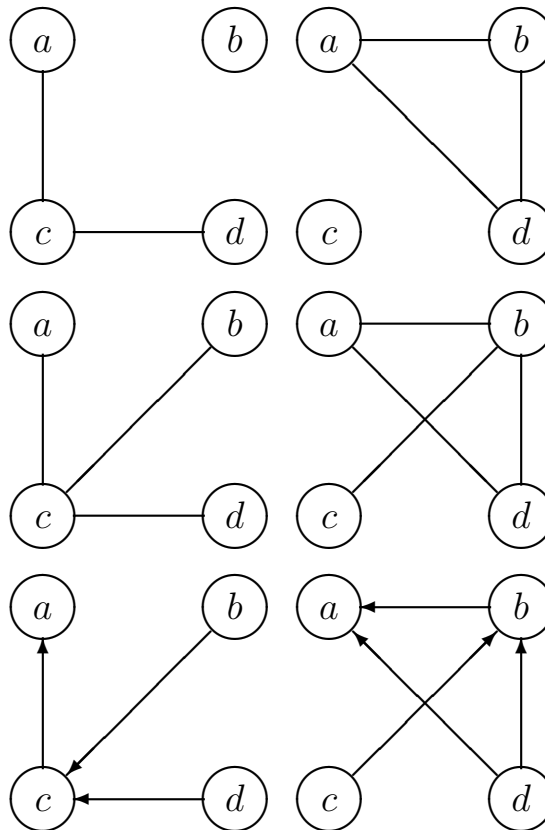



1.8.5.7 Differential inset (106)

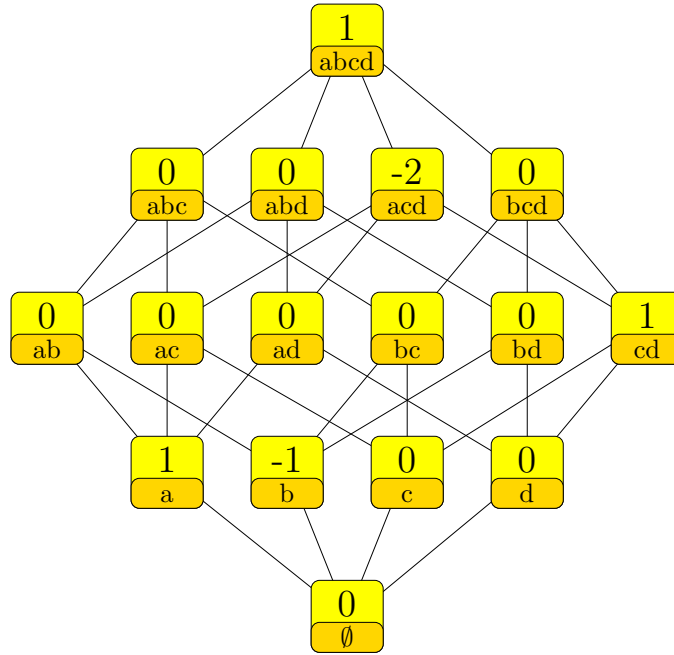

$$\begin{aligned}
 & \delta_{\{a\}} - \delta_{\{b\}} + \delta_{\{c,d\}} - 2\delta_{\{a,c,d\}} + \delta_{\{a,b,c,d\}} \\
 &= u_{\langle a,b|\emptyset \rangle} - u_{\langle a,c|\emptyset \rangle} + u_{\langle b,d|ac \rangle} + u_{\langle b,c|a \rangle} - u_{\langle a,d|c \rangle} \\
 &= (+2\delta_{\emptyset} - \delta_{\{b\}} - \delta_{\{c\}} - \delta_{\{d\}} + \delta_{\{c,d\}} - \delta_{\{a,c,d\}} + \delta_{\{a,b,c,d\}}) \\
 &\quad - (+2\delta_{\emptyset} - \delta_{\{a\}} - \delta_{\{c\}} - \delta_{\{d\}} + \delta_{\{a,c,d\}})
 \end{aligned}$$

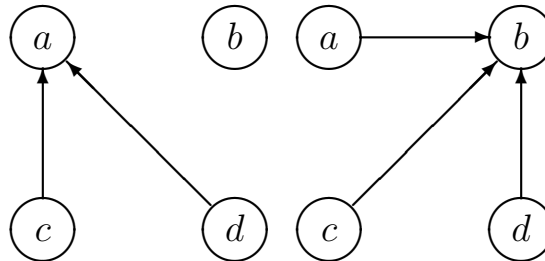

1.8.8 Number of nonzero values 8

1.8.8.1 Differential inset (107)

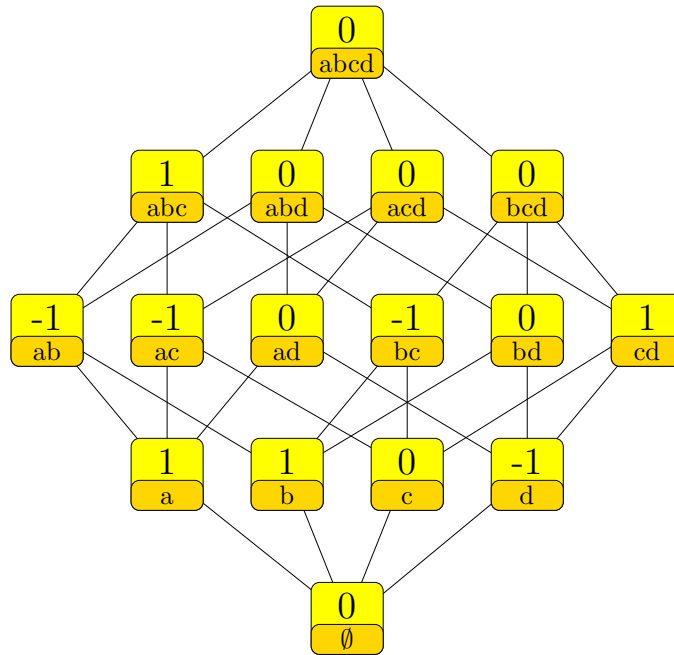

$$\begin{aligned}
 & \delta_{\{a\}} + \delta_{\{b\}} - \delta_{\{d\}} - \delta_{\{a,b\}} - \delta_{\{a,c\}} - \delta_{\{b,c\}} + \delta_{\{c,d\}} + \delta_{\{a,b,c\}} \\
 &= -u_{\langle b,c|\emptyset \rangle} + u_{\langle c,d|\emptyset \rangle} + u_{\langle b,c|a \rangle} \\
 &= (\delta_{\emptyset} + \delta_{\{a\}} - \delta_{\{d\}} - \delta_{\{a,b\}} - \delta_{\{a,c\}} + \delta_{\{a,b,c,d\}}) \\
 &\quad - (\delta_{\emptyset} - \delta_{\{b\}} + \delta_{\{b,c\}} - \delta_{\{c,d\}} - \delta_{\{a,b,c\}} + \delta_{\{a,b,c,d\}}) \\
 &= (\delta_{\emptyset} + \delta_{\{c\}} - \delta_{\{d\}} - \delta_{\{a,c\}} - \delta_{\{b,c\}} + \delta_{\{a,b,c,d\}}) \\
 &\quad - (\delta_{\emptyset} - \delta_{\{a\}} - \delta_{\{b\}} + \delta_{\{c\}} + \delta_{\{a,b\}} - \delta_{\{c,d\}} - \delta_{\{a,b,c\}} + \delta_{\{a,b,c,d\}})
 \end{aligned}$$

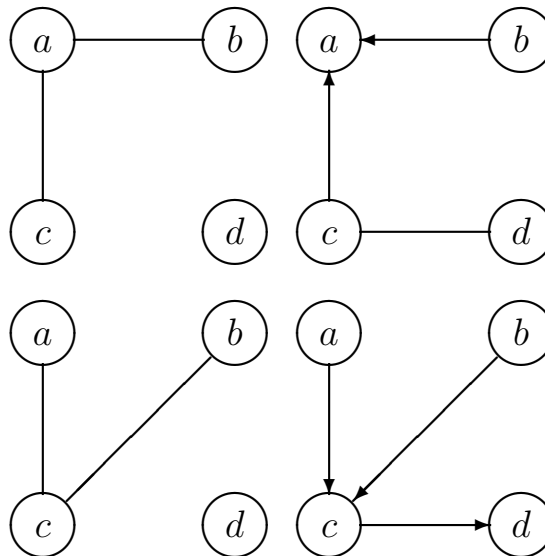

1.8.8.2 Differential inset (108)

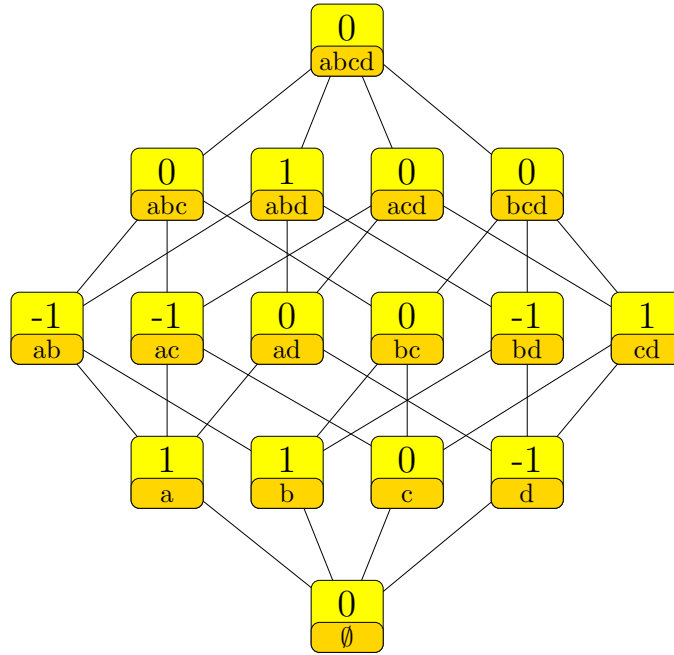

$$\begin{aligned}
 & \delta_{\{a\}} + \delta_{\{b\}} - \delta_{\{d\}} - \delta_{\{a,b\}} - \delta_{\{a,c\}} - \delta_{\{b,d\}} + \delta_{\{c,d\}} + \delta_{\{a,b,d\}} \\
 &= -u_{\langle a,c|\emptyset \rangle} + u_{\langle c,d|\emptyset \rangle} + u_{\langle a,d|b \rangle} \\
 &= (\delta_{\emptyset} + \delta_{\{a\}} - \delta_{\{d\}} - \delta_{\{a,b\}} - \delta_{\{a,c\}} + \delta_{\{a,b,c,d\}}) \\
 &\quad - (\delta_{\emptyset} - \delta_{\{b\}} + \delta_{\{b,d\}} - \delta_{\{c,d\}} - \delta_{\{a,b,d\}} + \delta_{\{a,b,c,d\}}) \\
 &= (\delta_{\emptyset} - \delta_{\{d\}} - \delta_{\{a,c\}} + \delta_{\{c,d\}} - \delta_{\{b,c,d\}} + \delta_{\{a,b,c,d\}}) \\
 &\quad - (\delta_{\emptyset} - \delta_{\{a\}} - \delta_{\{b\}} + \delta_{\{a,b\}} + \delta_{\{b,d\}} - \delta_{\{a,b,d\}} - \delta_{\{b,c,d\}} + \delta_{\{a,b,c,d\}})
 \end{aligned}$$

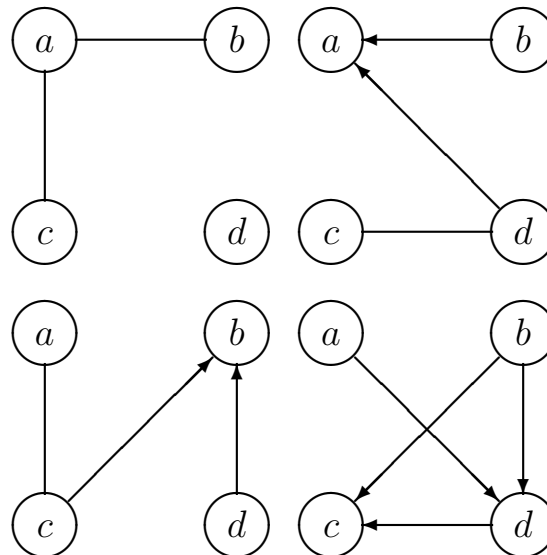

1.8.8.3 Differential inset (109)

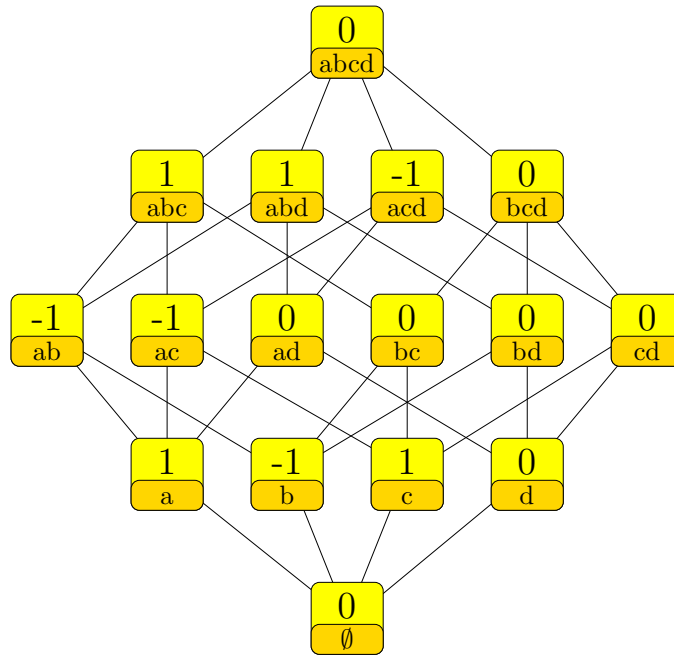

$$\begin{aligned}
 & \delta_{\{a\}} - \delta_{\{b\}} + \delta_{\{c\}} - \delta_{\{a,b\}} - \delta_{\{a,c\}} + \delta_{\{a,b,c\}} + \delta_{\{a,b,d\}} - \delta_{\{a,c,d\}} \\
 &= u_{\langle a,b|\emptyset \rangle} - u_{\langle a,c|\emptyset \rangle} - u_{\langle c,d|ab \rangle} + u_{\langle b,d|ac \rangle} + u_{\langle b,c|a \rangle} \\
 &= (\delta_{\emptyset} - \delta_{\{b\}} - \delta_{\{a,c,d\}} + \delta_{\{a,b,c,d\}}) \\
 &\quad - (\delta_{\emptyset} - \delta_{\{a\}} - \delta_{\{c\}} + \delta_{\{a,b\}} + \delta_{\{a,c\}} - \delta_{\{a,b,c\}} - \delta_{\{a,b,d\}} + \delta_{\{a,b,c,d\}})
 \end{aligned}$$

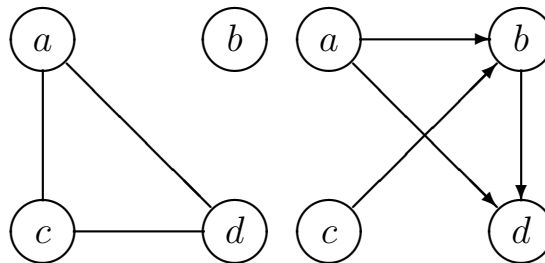

1.8.8.4 Differential inset (110)

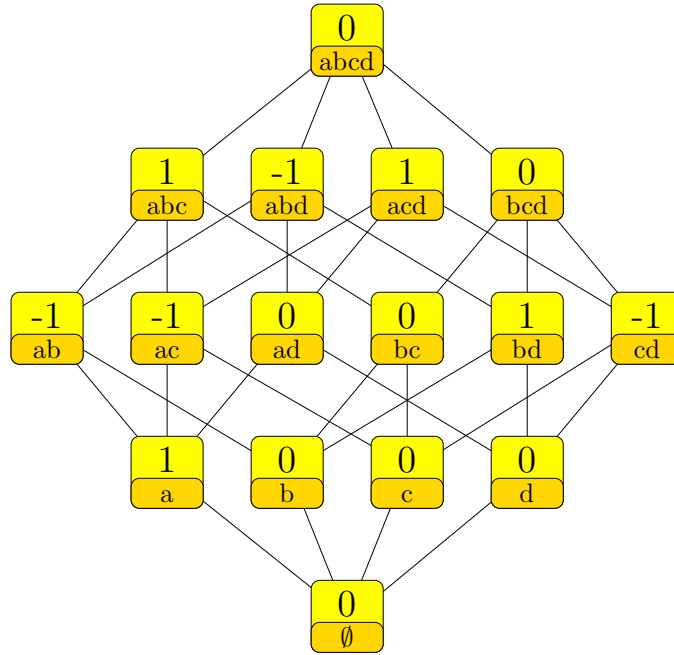

$$\begin{aligned}
 & \delta_{\{a\}} - \delta_{\{a,b\}} - \delta_{\{a,c\}} + \delta_{\{b,d\}} - \delta_{\{c,d\}} + \delta_{\{a,b,c\}} - \delta_{\{a,b,d\}} + \delta_{\{a,c,d\}} \\
 &= u_{\langle a,c|bd \rangle} - u_{\langle a,b|cd \rangle} + u_{\langle b,c|a \rangle} \\
 &= (\delta_{\emptyset} - \delta_{\{b\}} + \delta_{\{b,d\}} - \delta_{\{c,d\}} - \delta_{\{a,b,d\}} + \delta_{\{a,b,c,d\}}) \\
 &\quad - (\delta_{\emptyset} - \delta_{\{a\}} - \delta_{\{b\}} + \delta_{\{a,b\}} + \delta_{\{a,c\}} - \delta_{\{a,b,c\}} - \delta_{\{a,c,d\}} + \delta_{\{a,b,c,d\}})
 \end{aligned}$$

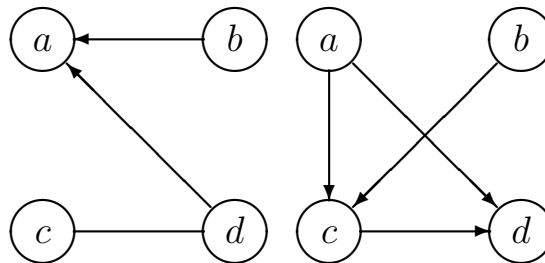

1.8.8.5 Differential inset (111)

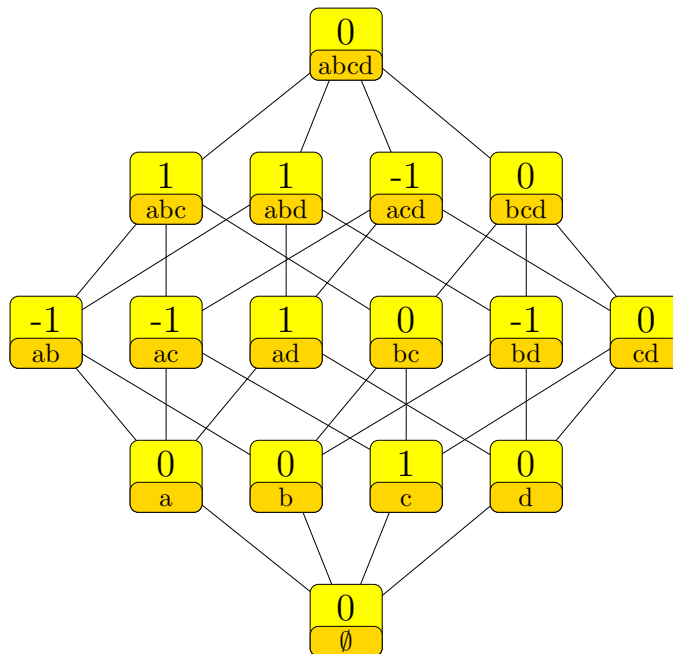

$$\begin{aligned}
 & \delta_{\{c\}} - \delta_{\{a,b\}} - \delta_{\{a,c\}} + \delta_{\{a,d\}} - \delta_{\{b,d\}} + \delta_{\{a,b,c\}} + \delta_{\{a,b,d\}} - \delta_{\{a,c,d\}} \\
 &= u_{\langle a,b|\emptyset \rangle} - u_{\langle a,c|\emptyset \rangle} - u_{\langle c,d|ab \rangle} + u_{\langle b,c|ad \rangle} + u_{\langle a,d|b \rangle} \\
 &= (\delta_{\emptyset} - \delta_{\{a\}} + \delta_{\{a,d\}} - \delta_{\{b,d\}} - \delta_{\{a,c,d\}} + \delta_{\{a,b,c,d\}}) \\
 &\quad - (\delta_{\emptyset} - \delta_{\{a\}} - \delta_{\{c\}} + \delta_{\{a,b\}} + \delta_{\{a,c\}} - \delta_{\{a,b,c\}} - \delta_{\{a,b,d\}} + \delta_{\{a,b,c,d\}})
 \end{aligned}$$

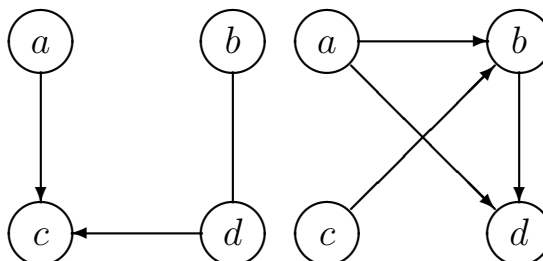

1.8.8.6 Differential inset (112)

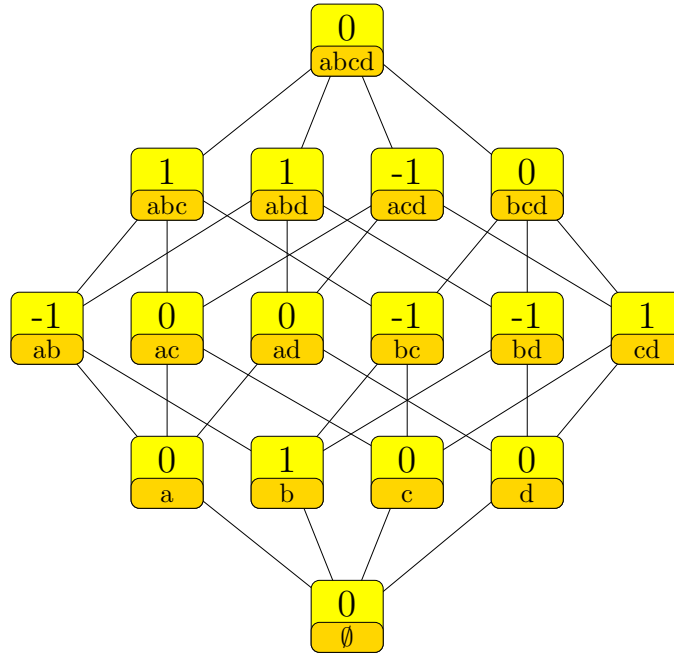

$$\begin{aligned}
 & \delta_{\{b\}} - \delta_{\{a,b\}} - \delta_{\{b,c\}} - \delta_{\{b,d\}} + \delta_{\{c,d\}} + \delta_{\{a,b,c\}} + \delta_{\{a,b,d\}} - \delta_{\{a,c,d\}} \\
 &= -u_{\langle c,d|ab \rangle} + u_{\langle a,b|cd \rangle} + u_{\langle c,d|b \rangle} \\
 &= (\delta_{\emptyset} - \delta_{\{c\}} - \delta_{\{b,d\}} + \delta_{\{c,d\}} - \delta_{\{a,c,d\}} + \delta_{\{a,b,c,d\}}) \\
 &\quad - (\delta_{\emptyset} - \delta_{\{b\}} - \delta_{\{c\}} + \delta_{\{a,b\}} + \delta_{\{b,c\}} - \delta_{\{a,b,c\}} - \delta_{\{a,b,d\}} + \delta_{\{a,b,c,d\}})
 \end{aligned}$$

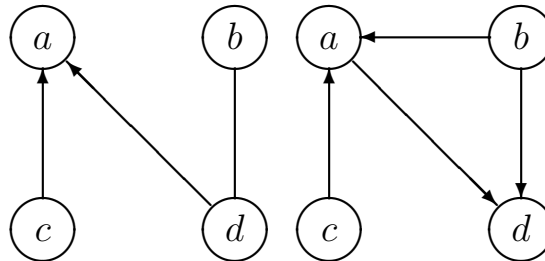

1.8.8.7 Differential inset (113)

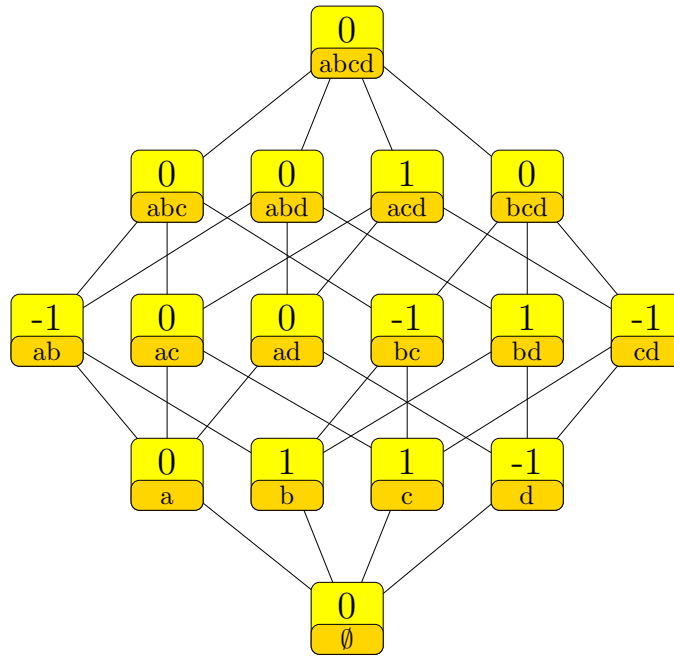

$$\begin{aligned}
 & \delta_{\{b\}} + \delta_{\{c\}} - \delta_{\{d\}} - \delta_{\{a,b\}} - \delta_{\{b,c\}} + \delta_{\{b,d\}} - \delta_{\{c,d\}} + \delta_{\{a,c,d\}} \\
 &= -u_{\langle a,b|\emptyset \rangle} + u_{\langle a,c|\emptyset \rangle} - u_{\langle b,c|\emptyset \rangle} + u_{\langle b,d|\emptyset \rangle} + u_{\langle a,d|c \rangle} \\
 &= (\delta_{\emptyset} + \delta_{\{b\}} - \delta_{\{d\}} - \delta_{\{a,b\}} - \delta_{\{b,c\}} + \delta_{\{a,b,c,d\}}) \\
 &\quad - (\delta_{\emptyset} - \delta_{\{c\}} - \delta_{\{b,d\}} + \delta_{\{c,d\}} - \delta_{\{a,c,d\}} + \delta_{\{a,b,c,d\}})
 \end{aligned}$$

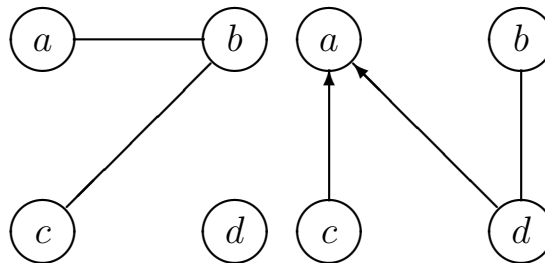



1.8.8.8 Differential inset (114)

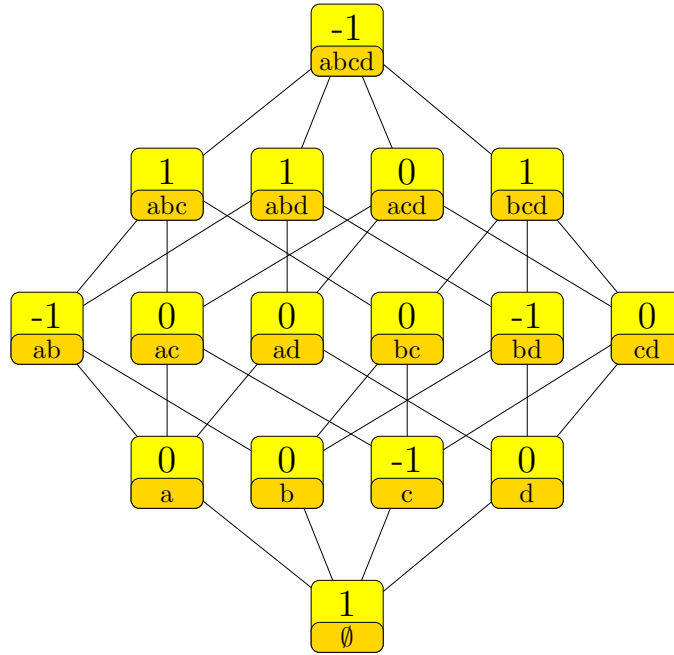

$$\begin{aligned}
 \delta_\emptyset - \delta_{\{c\}} - \delta_{\{a,b\}} - \delta_{\{b,d\}} + \delta_{\{a,b,c\}} + \delta_{\{a,b,d\}} + \delta_{\{b,c,d\}} - \delta_{\{a,b,c,d\}} \\
 &= u_{\langle b,c|\emptyset \rangle} - u_{\langle c,d|ab \rangle} + u_{\langle c,d|b \rangle} \\
 &= (+2\delta_\emptyset - \delta_{\{b\}} - \delta_{\{c\}} - \delta_{\{d\}} + \delta_{\{b,c,d\}}) \\
 &\quad - (\delta_\emptyset - \delta_{\{b\}} - \delta_{\{d\}} + \delta_{\{a,b\}} + \delta_{\{b,d\}} - \delta_{\{a,b,c\}} - \delta_{\{a,b,d\}} + \delta_{\{a,b,c,d\}})
 \end{aligned}$$

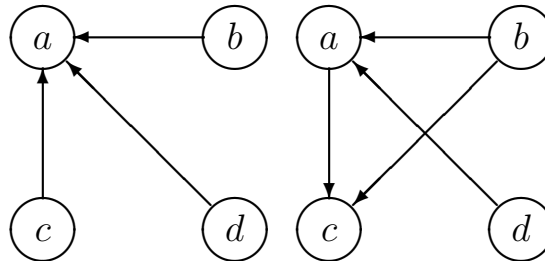

1.8.8.9 Differential inset (115)

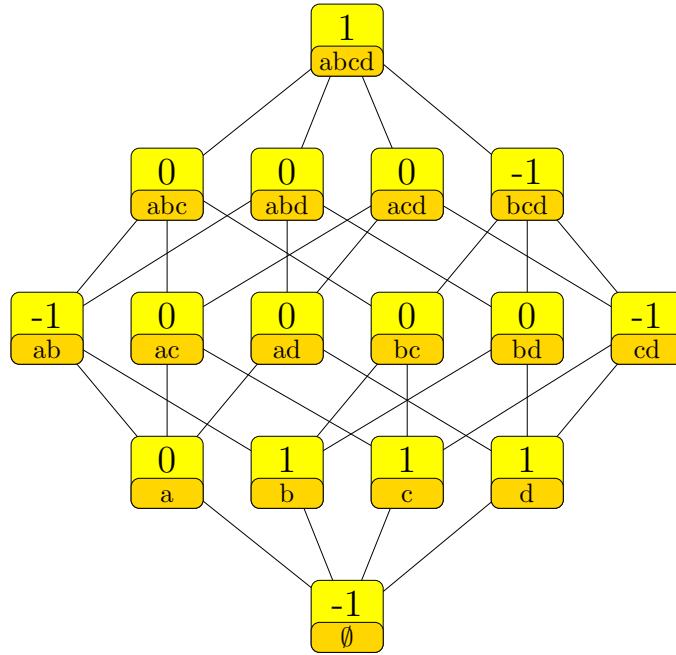

$$\begin{aligned}
 & -\delta_\emptyset + \delta_{\{b\}} + \delta_{\{c\}} + \delta_{\{d\}} - \delta_{\{a,b\}} - \delta_{\{c,d\}} - \delta_{\{b,c,d\}} + \delta_{\{a,b,c,d\}} \\
 &= -u_{\langle c,d|\emptyset \rangle} + u_{\langle a,d|bc \rangle} + u_{\langle a,c|b \rangle} \\
 &= (\delta_\emptyset - \delta_{\{a,b\}} - \delta_{\{c,d\}} + \delta_{\{a,b,c,d\}}) \\
 &\quad - (+2\delta_\emptyset - \delta_{\{b\}} - \delta_{\{c\}} - \delta_{\{d\}} + \delta_{\{b,c,d\}}) \\
 &= (\delta_{\{b\}} - \delta_{\{a,b\}} - \delta_{\{b,c,d\}} + \delta_{\{a,b,c,d\}}) \\
 &\quad - (\delta_\emptyset - \delta_{\{c\}} - \delta_{\{d\}} + \delta_{\{c,d\}})
 \end{aligned}$$

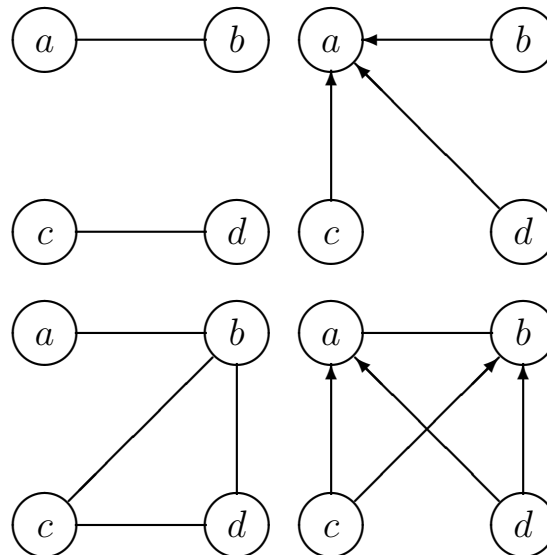

1.8.8.10 Differential imset (116)

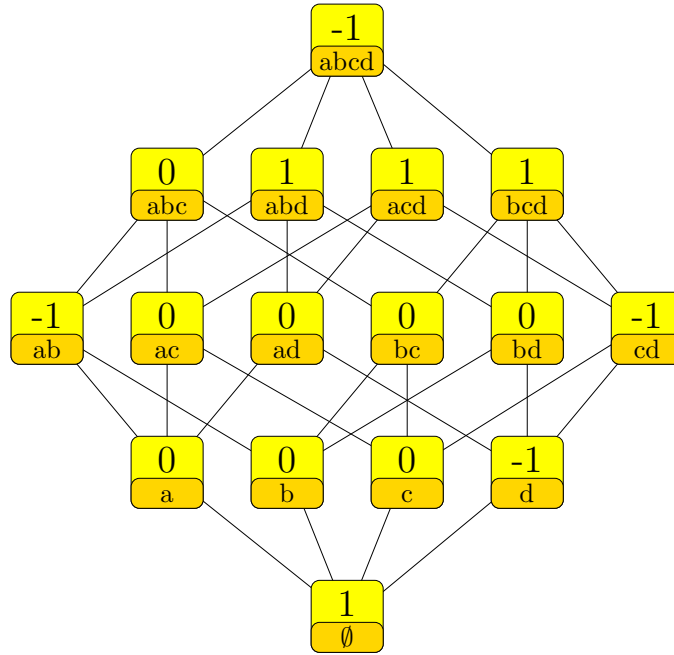

$$\begin{aligned}
 & \delta_{\emptyset} - \delta_{\{d\}} - \delta_{\{a,b\}} - \delta_{\{c,d\}} + \delta_{\{a,b,d\}} + \delta_{\{a,c,d\}} + \delta_{\{b,c,d\}} - \delta_{\{a,b,c,d\}} \\
 &= u_{\langle a,d|\emptyset \rangle} - u_{\langle a,b|cd \rangle} + u_{\langle b,d|a \rangle} \\
 &= (\delta_{\emptyset} - \delta_{\{d\}} - \delta_{\{a,b\}} + \delta_{\{a,b,d\}}) \\
 &\quad - (\delta_{\{c,d\}} - \delta_{\{a,c,d\}} - \delta_{\{b,c,d\}} + \delta_{\{a,b,c,d\}})
 \end{aligned}$$

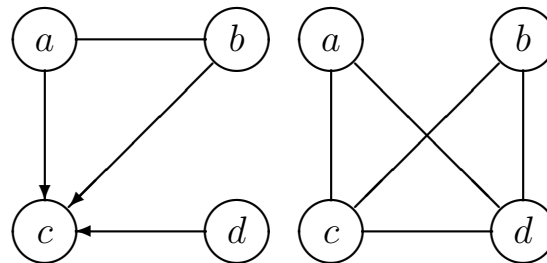

1.8.8.11 Differential imset (117)

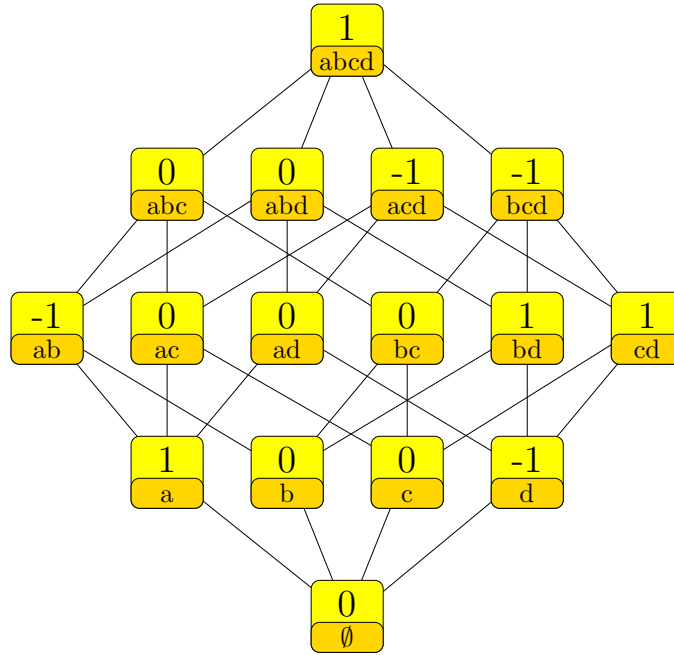

$$\begin{aligned}
 & \delta_{\{a\}} - \delta_{\{d\}} - \delta_{\{a,b\}} + \delta_{\{b,d\}} + \delta_{\{c,d\}} - \delta_{\{a,c,d\}} - \delta_{\{b,c,d\}} + \delta_{\{a,b,c,d\}} \\
 &= -u_{\langle a,b|\emptyset \rangle} + u_{\langle b,d|\emptyset \rangle} + u_{\langle a,b|cd \rangle} \\
 &= (\delta_{\emptyset} + \delta_{\{a\}} - \delta_{\{c\}} - \delta_{\{d\}} - \delta_{\{a,b\}} + \delta_{\{c,d\}} - \delta_{\{a,c,d\}} + \delta_{\{a,b,c,d\}}) \\
 &\quad - (\delta_{\emptyset} - \delta_{\{c\}} - \delta_{\{b,d\}} + \delta_{\{b,c,d\}}) \\
 &= (\delta_{\{a\}} - \delta_{\{a,b\}} - \delta_{\{a,d\}} + \delta_{\{b,d\}} - \delta_{\{b,c,d\}} + \delta_{\{a,b,c,d\}}) \\
 &\quad - (\delta_{\{d\}} - \delta_{\{a,d\}} - \delta_{\{c,d\}} + \delta_{\{a,c,d\}})
 \end{aligned}$$

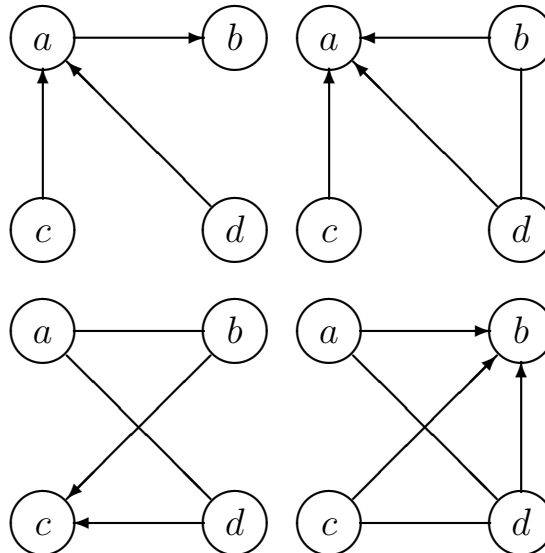

1.8.8.12 Differential imset (118)

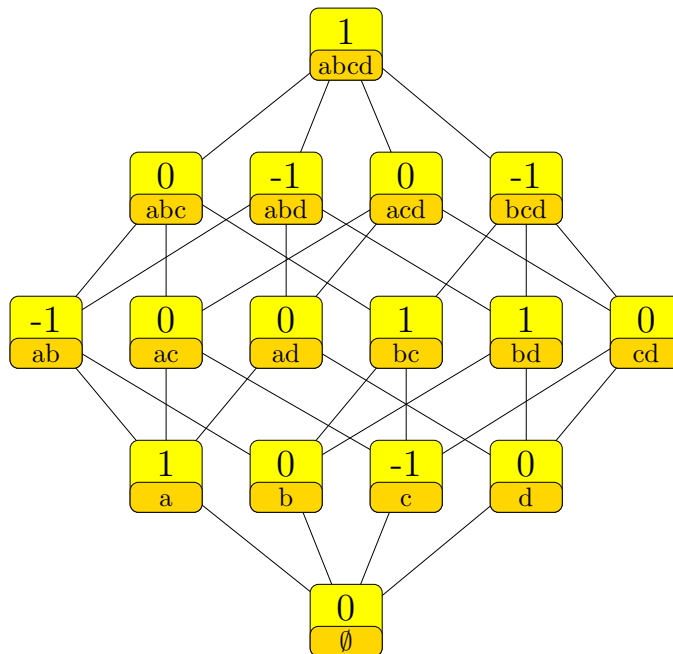

$$\begin{aligned}
 & \delta_{\{a\}} - \delta_{\{c\}} - \delta_{\{a,b\}} + \delta_{\{b,c\}} + \delta_{\{b,d\}} - \delta_{\{a,b,d\}} - \delta_{\{b,c,d\}} + \delta_{\{a,b,c,d\}} \\
 &= -u_{\langle a,b|\emptyset \rangle} + u_{\langle b,c|\emptyset \rangle} + u_{\langle a,c|bd \rangle} \\
 &= (\delta_{\emptyset} - \delta_{\{c\}} - \delta_{\{a,b\}} + \delta_{\{b,c\}} - \delta_{\{b,c,d\}} + \delta_{\{a,b,c,d\}}) \\
 &\quad - (\delta_{\emptyset} - \delta_{\{a\}} - \delta_{\{b,d\}} + \delta_{\{a,b,d\}})
 \end{aligned}$$

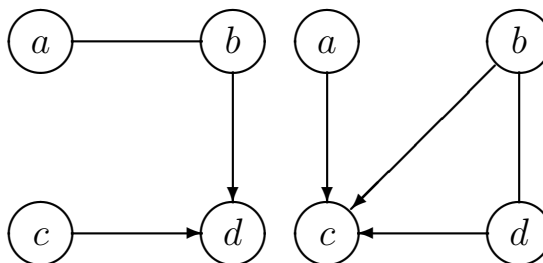

1.8.8.13 Differential imset (119)

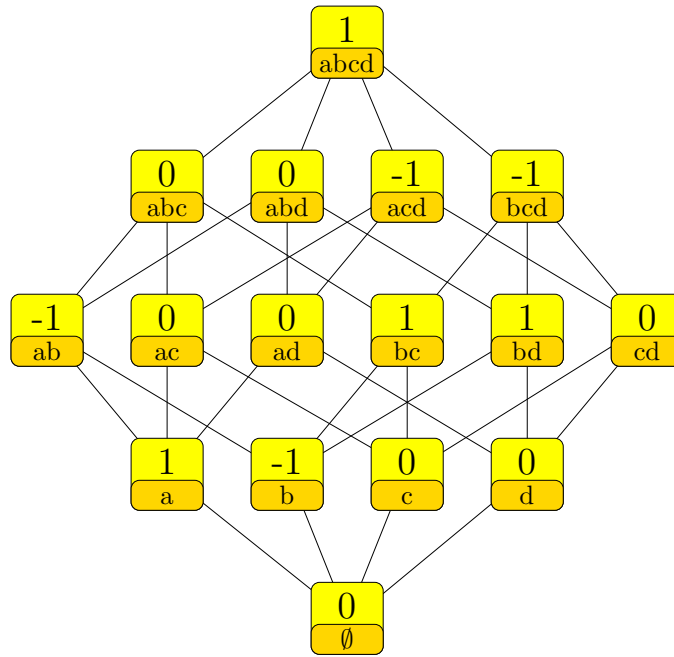

$$\begin{aligned}
 & \delta_{\{a\}} - \delta_{\{b\}} - \delta_{\{a,b\}} + \delta_{\{b,c\}} + \delta_{\{b,d\}} - \delta_{\{a,c,d\}} - \delta_{\{b,c,d\}} + \delta_{\{a,b,c,d\}} \\
 &= u_{\langle b,d|ac \rangle} + u_{\langle b,c|a \rangle} - u_{\langle c,d|b \rangle} \\
 &= (\delta_{\{a\}} - \delta_{\{a,b\}} - \delta_{\{a,c,d\}} + \delta_{\{a,b,c,d\}}) \\
 &\quad - (\delta_{\{b\}} - \delta_{\{b,c\}} - \delta_{\{b,d\}} + \delta_{\{b,c,d\}})
 \end{aligned}$$

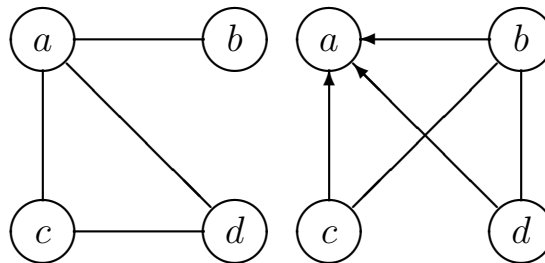

1.8.8.14 Differential imset (120)

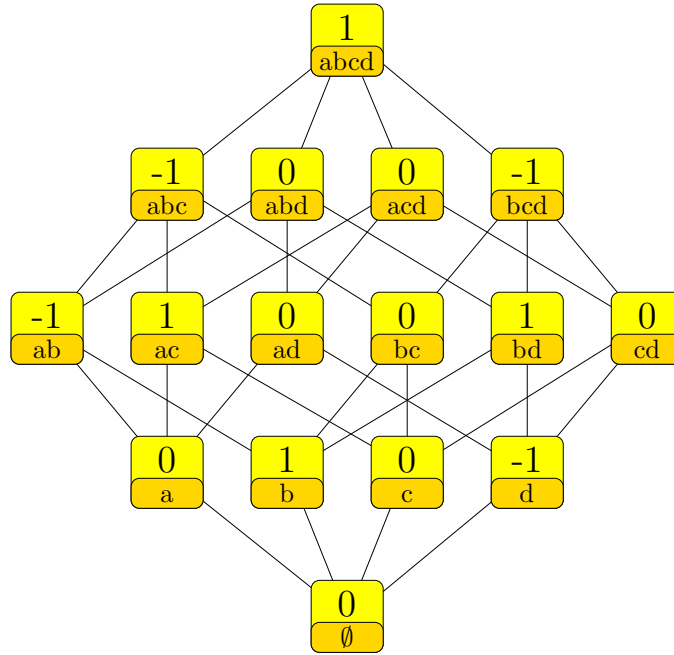

$$\begin{aligned}
 & \delta_{\{b\}} - \delta_{\{d\}} - \delta_{\{a,b\}} + \delta_{\{a,c\}} + \delta_{\{b,d\}} - \delta_{\{a,b,c\}} - \delta_{\{b,c,d\}} + \delta_{\{a,b,c,d\}} \\
 &= -u_{\langle a,b|\emptyset \rangle} + u_{\langle a,d|\emptyset \rangle} + u_{\langle a,c|bd \rangle} - u_{\langle b,c|a \rangle} + u_{\langle b,d|a \rangle} \\
 &= (\delta_{\emptyset} - \delta_{\{d\}} - \delta_{\{a,b\}} + \delta_{\{b,d\}} - \delta_{\{b,c,d\}} + \delta_{\{a,b,c,d\}}) \\
 &\quad - (\delta_{\emptyset} - \delta_{\{b\}} - \delta_{\{a,c\}} + \delta_{\{a,b,c\}})
 \end{aligned}$$

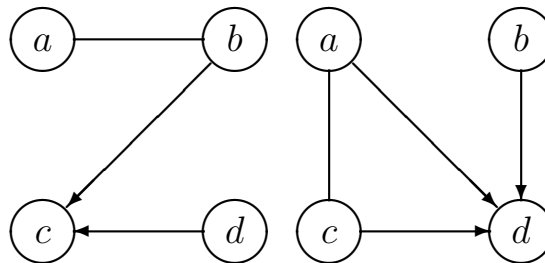

1.8.8.15 Differential imset (121)

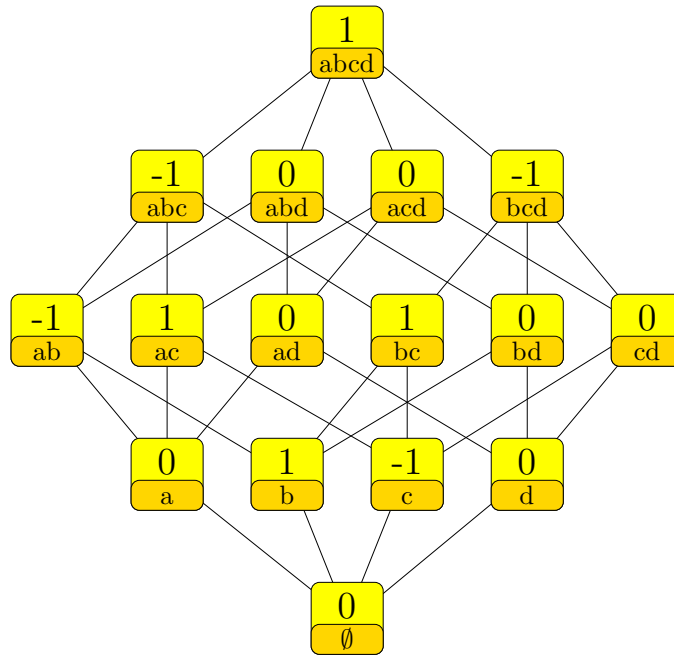

$$\begin{aligned}
 & \delta_{\{b\}} - \delta_{\{c\}} - \delta_{\{a,b\}} + \delta_{\{a,c\}} + \delta_{\{b,c\}} - \delta_{\{a,b,c\}} - \delta_{\{b,c,d\}} + \delta_{\{a,b,c,d\}} \\
 &= -u_{\langle a,b|\emptyset \rangle} + u_{\langle a,c|\emptyset \rangle} + u_{\langle a,d|bc \rangle} \\
 &= (\delta_{\emptyset} - \delta_{\{c\}} - \delta_{\{a,b\}} + \delta_{\{b,c\}} - \delta_{\{b,c,d\}} + \delta_{\{a,b,c,d\}}) \\
 &\quad - (\delta_{\emptyset} - \delta_{\{b\}} - \delta_{\{a,c\}} + \delta_{\{a,b,c\}})
 \end{aligned}$$

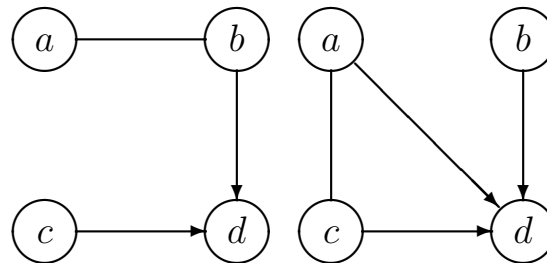



1.8.8.16 Differential imset (122)

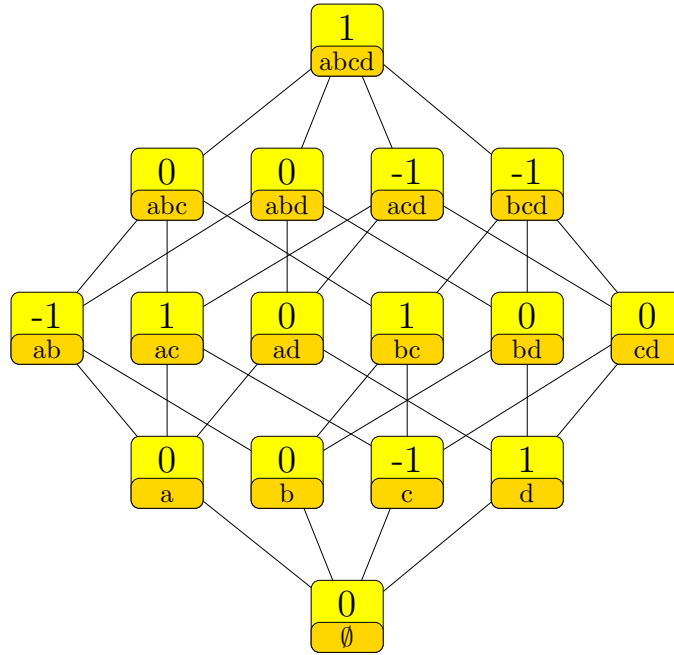

$$\begin{aligned}
 & -\delta_{\{c\}} + \delta_{\{d\}} - \delta_{\{a,b\}} + \delta_{\{a,c\}} + \delta_{\{b,c\}} - \delta_{\{a,c,d\}} - \delta_{\{b,c,d\}} + \delta_{\{a,b,c,d\}} \\
 &= u_{\langle a,c|\emptyset \rangle} - u_{\langle a,d|\emptyset \rangle} + u_{\langle a,d|bc \rangle} + u_{\langle b,c|a \rangle} - u_{\langle c,d|a \rangle} \\
 &= (\delta_{\emptyset} - \delta_{\{c\}} - \delta_{\{a,b\}} + \delta_{\{b,c\}} - \delta_{\{b,c,d\}} + \delta_{\{a,b,c,d\}}) \\
 &\quad - (\delta_{\emptyset} - \delta_{\{d\}} - \delta_{\{a,c\}} + \delta_{\{a,c,d\}}) \\
 &= (\delta_{\emptyset} - \delta_{\{c\}} - \delta_{\{a,b\}} + \delta_{\{a,c\}} - \delta_{\{a,c,d\}} + \delta_{\{a,b,c,d\}}) \\
 &\quad - (\delta_{\emptyset} - \delta_{\{d\}} - \delta_{\{b,c\}} + \delta_{\{b,c,d\}})
 \end{aligned}$$

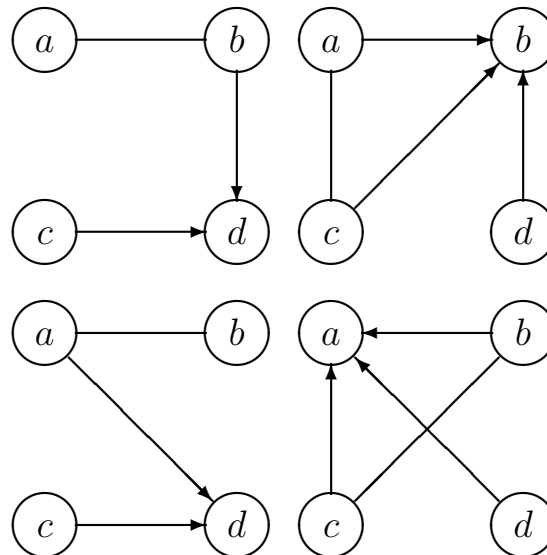

1.8.8.17 Differential imset (123)

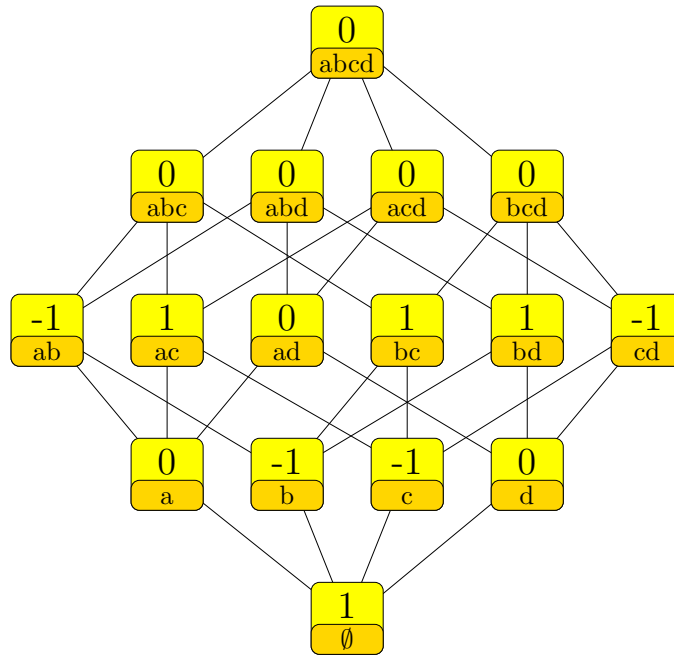

$$\begin{aligned}
 & \delta_\emptyset - \delta_{\{b\}} - \delta_{\{c\}} - \delta_{\{a,b\}} + \delta_{\{a,c\}} + \delta_{\{b,c\}} + \delta_{\{b,d\}} - \delta_{\{c,d\}} \\
 &= -u_{\langle a,b|\emptyset \rangle} + u_{\langle a,c|\emptyset \rangle} + u_{\langle b,c|\emptyset \rangle} + u_{\langle b,d|\emptyset \rangle} - u_{\langle c,d|\emptyset \rangle} \\
 &= (\delta_\emptyset - \delta_{\{a,b\}} - \delta_{\{c,d\}} + \delta_{\{a,b,c,d\}}) \\
 &\quad - (\delta_{\{b\}} + \delta_{\{c\}} - \delta_{\{a,c\}} - \delta_{\{b,c\}} - \delta_{\{b,d\}} + \delta_{\{a,b,c,d\}})
 \end{aligned}$$

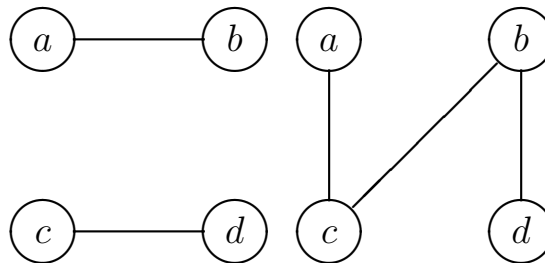

1.8.8.18 Differential imset (124)

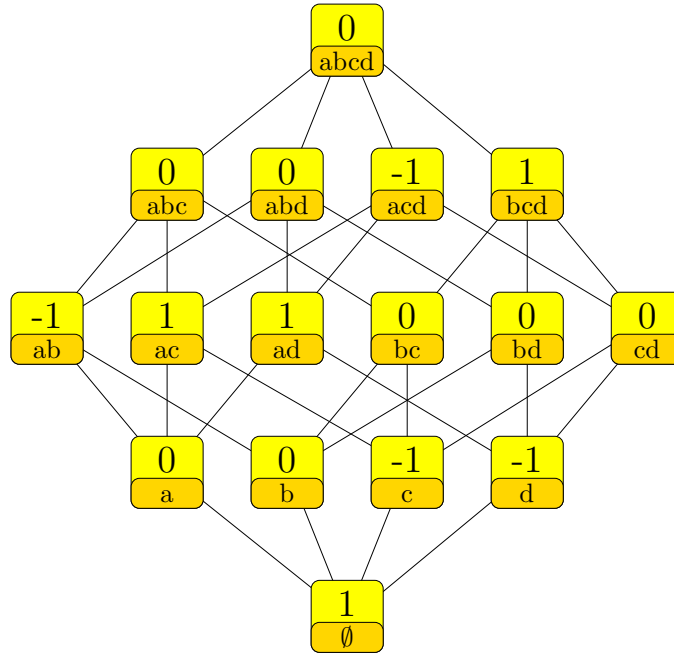

$$\begin{aligned}
 & \delta_\emptyset - \delta_{\{c\}} - \delta_{\{d\}} - \delta_{\{a,b\}} + \delta_{\{a,c\}} + \delta_{\{a,d\}} - \delta_{\{a,c,d\}} + \delta_{\{b,c,d\}} \\
 &= u_{\langle c,d|\emptyset \rangle} + u_{\langle b,d|ac \rangle} - u_{\langle a,b|cd \rangle} + u_{\langle b,c|a \rangle} - u_{\langle c,d|a \rangle} \\
 &= (\delta_\emptyset + \delta_{\{a\}} - \delta_{\{c\}} - \delta_{\{d\}} - \delta_{\{a,b\}} + \delta_{\{c,d\}} - \delta_{\{a,c,d\}} + \delta_{\{a,b,c,d\}}) \\
 &\quad - (\delta_{\{a\}} - \delta_{\{a,c\}} - \delta_{\{a,d\}} + \delta_{\{c,d\}} - \delta_{\{b,c,d\}} + \delta_{\{a,b,c,d\}})
 \end{aligned}$$

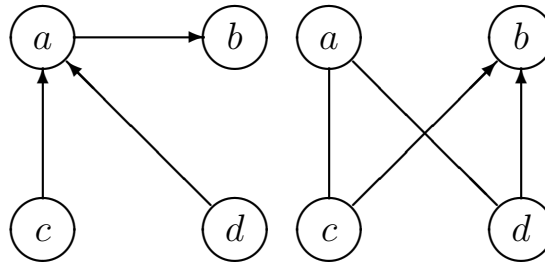

1.8.8.19 Differential imset (125)

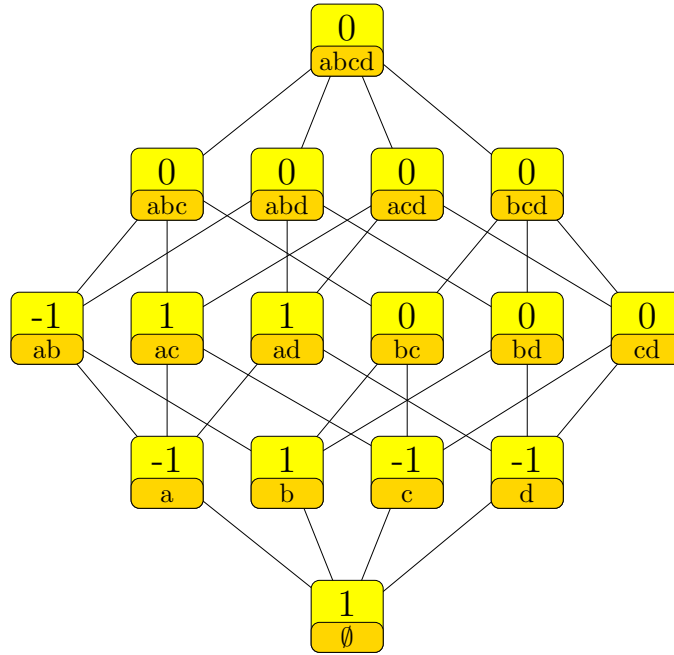

$$\begin{aligned}
 & \delta_\emptyset - \delta_{\{a\}} + \delta_{\{b\}} - \delta_{\{c\}} - \delta_{\{d\}} - \delta_{\{a,b\}} + \delta_{\{a,c\}} + \delta_{\{a,d\}} \\
 &= -u_{\langle a,b|\emptyset \rangle} + u_{\langle a,c|\emptyset \rangle} + u_{\langle a,d|\emptyset \rangle} \\
 &= (+2\delta_\emptyset - \delta_{\{c\}} - \delta_{\{d\}} - \delta_{\{a,b\}} + \delta_{\{a,b,c,d\}}) \\
 &\quad - (\delta_\emptyset + \delta_{\{a\}} - \delta_{\{b\}} - \delta_{\{a,c\}} - \delta_{\{a,d\}} + \delta_{\{a,b,c,d\}}) \\
 &= (\delta_\emptyset - \delta_{\{a\}} + \delta_{\{b\}} - \delta_{\{c\}} + \delta_{\{a,c\}} - \delta_{\{b,d\}} - \delta_{\{a,b,c\}} + \delta_{\{a,b,c,d\}}) \\
 &\quad - (\delta_{\{d\}} + \delta_{\{a,b\}} - \delta_{\{a,d\}} - \delta_{\{b,d\}} - \delta_{\{a,b,c\}} + \delta_{\{a,b,c,d\}})
 \end{aligned}$$

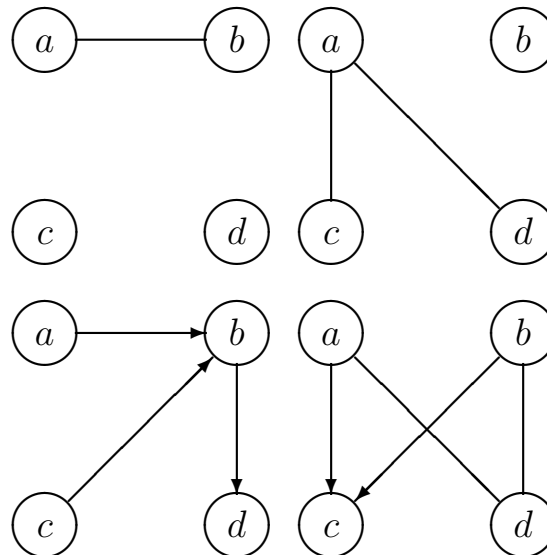

1.8.8.20 Differential imset (126)

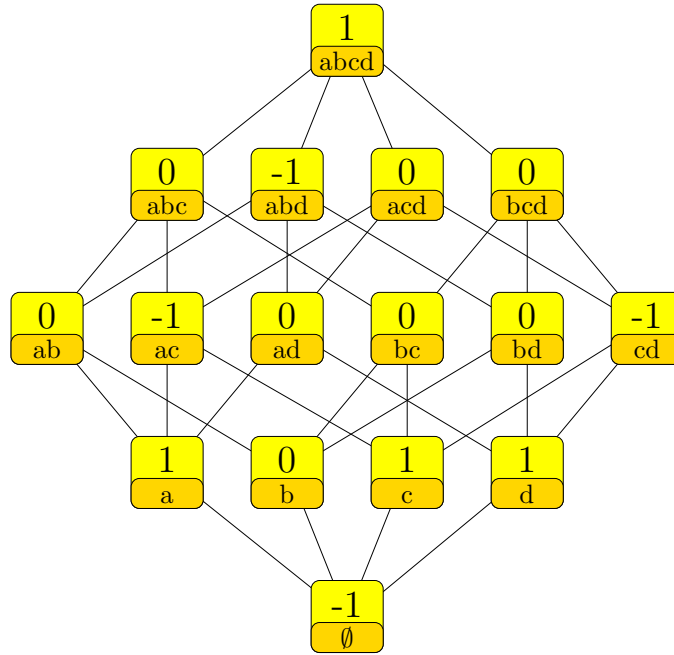

$$\begin{aligned}
 & -\delta_\emptyset + \delta_{\{a\}} + \delta_{\{c\}} + \delta_{\{d\}} - \delta_{\{a,c\}} - \delta_{\{c,d\}} - \delta_{\{a,b,d\}} + \delta_{\{a,b,c,d\}} \\
 &= -u_{\langle a,c|\emptyset \rangle} + u_{\langle b,c|ad \rangle} + u_{\langle a,c|d \rangle} \\
 &= (\delta_\emptyset - \delta_{\{b\}} + \delta_{\{c\}} - \delta_{\{a,c\}} - \delta_{\{c,d\}} + \delta_{\{a,b,c,d\}}) \\
 &\quad - (+2\delta_\emptyset - \delta_{\{a\}} - \delta_{\{b\}} - \delta_{\{d\}} + \delta_{\{a,b,d\}}) \\
 &= (\delta_{\{a\}} + \delta_{\{c\}} - \delta_{\{a,b\}} - \delta_{\{a,c\}} - \delta_{\{c,d\}} + \delta_{\{a,b,c,d\}}) \\
 &\quad - (\delta_\emptyset - \delta_{\{d\}} - \delta_{\{a,b\}} + \delta_{\{a,b,d\}}) \\
 &= (\delta_{\{c\}} + \delta_{\{d\}} - \delta_{\{a,c\}} - \delta_{\{b,d\}} - \delta_{\{c,d\}} + \delta_{\{a,b,c,d\}}) \\
 &\quad - (\delta_\emptyset - \delta_{\{a\}} - \delta_{\{b,d\}} + \delta_{\{a,b,d\}}) \\
 &= (\delta_{\{a\}} - \delta_{\{a,c\}} - \delta_{\{a,b,d\}} + \delta_{\{a,b,c,d\}}) \\
 &\quad - (\delta_\emptyset - \delta_{\{c\}} - \delta_{\{d\}} + \delta_{\{c,d\}}) \\
 &= (\delta_{\{d\}} - \delta_{\{c,d\}} - \delta_{\{a,b,d\}} + \delta_{\{a,b,c,d\}}) \\
 &\quad - (\delta_\emptyset - \delta_{\{a\}} - \delta_{\{c\}} + \delta_{\{a,c\}})
 \end{aligned}$$

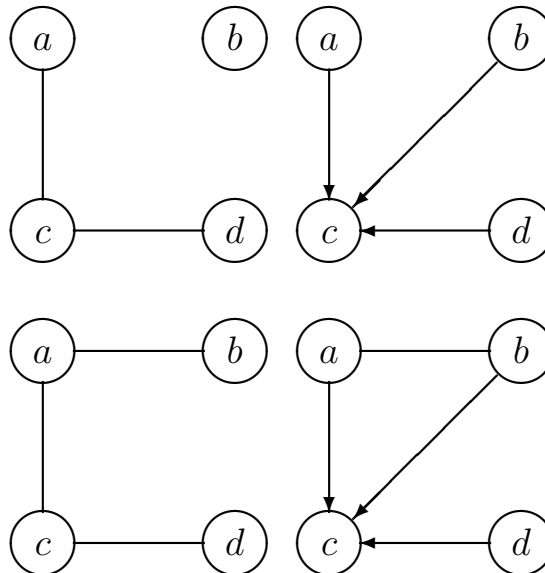

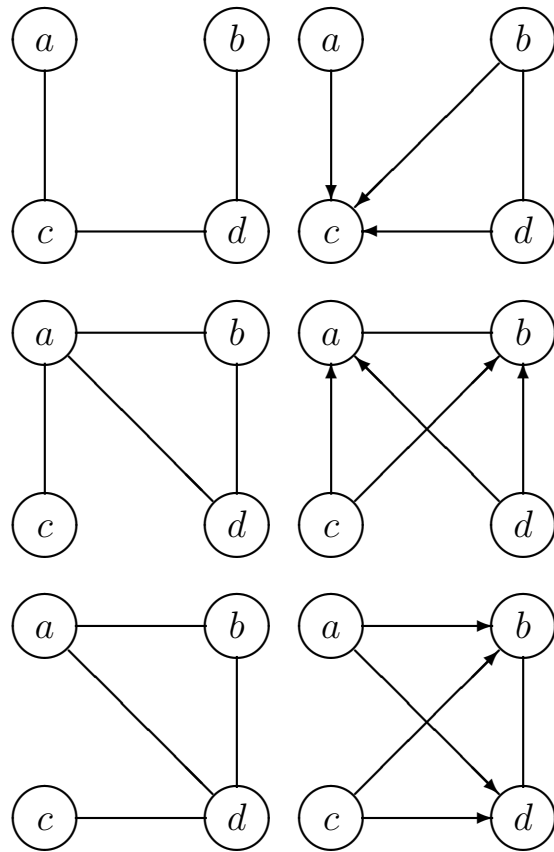

1.8.8.21 Differential imset (127)

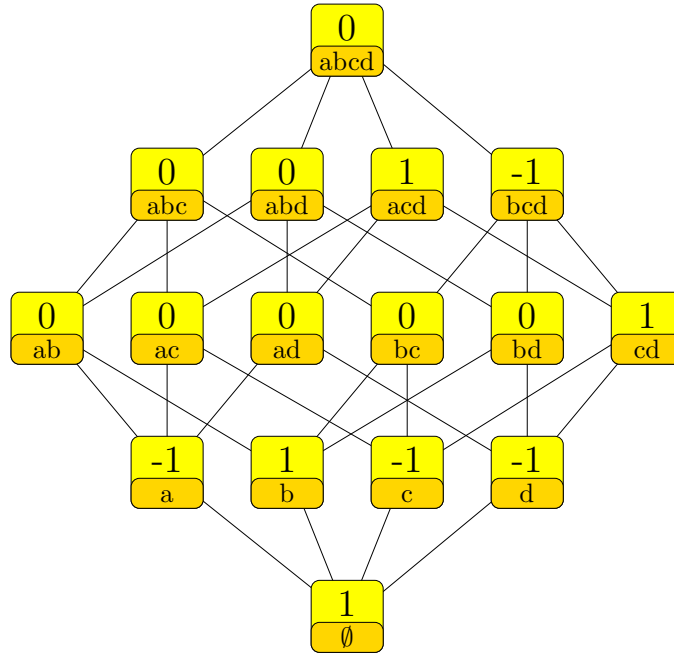

$$\begin{aligned}
 & \delta_\emptyset - \delta_{\{a\}} + \delta_{\{b\}} - \delta_{\{c\}} - \delta_{\{d\}} + \delta_{\{c,d\}} + \delta_{\{a,c,d\}} - \delta_{\{b,c,d\}} \\
 &= u_{\langle a,c|\emptyset \rangle} + u_{\langle a,d|\emptyset \rangle} - u_{\langle b,c|\emptyset \rangle} + u_{\langle c,d|a \rangle} - u_{\langle b,d|c \rangle} \\
 &= (+2\delta_\emptyset - \delta_{\{a\}} - \delta_{\{c\}} - \delta_{\{d\}} + \delta_{\{a,c,d\}}) \\
 &\quad - (\delta_\emptyset - \delta_{\{b\}} - \delta_{\{c,d\}} + \delta_{\{b,c,d\}})
 \end{aligned}$$

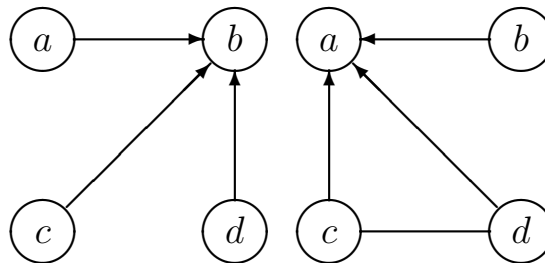

1.8.8.22 Differential imset (128)

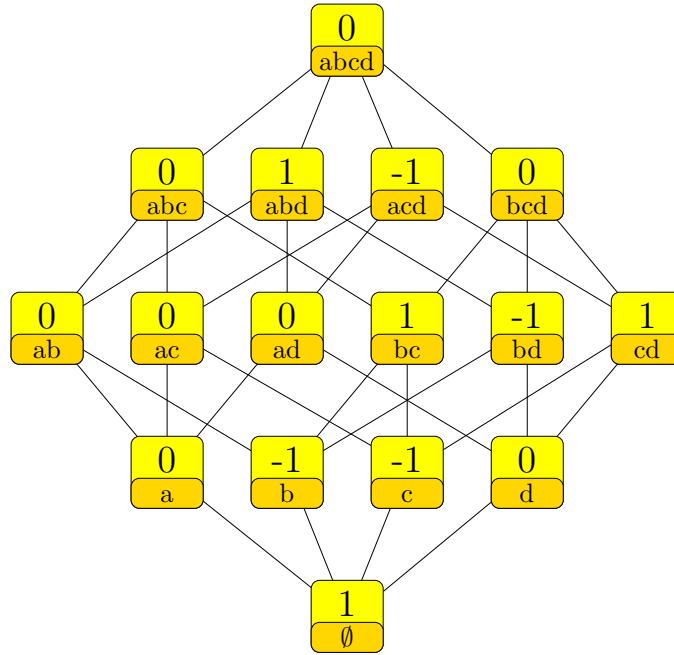

$$\begin{aligned}
 & \delta_\emptyset - \delta_{\{b\}} - \delta_{\{c\}} + \delta_{\{b,c\}} - \delta_{\{b,d\}} + \delta_{\{c,d\}} + \delta_{\{a,b,d\}} - \delta_{\{a,c,d\}} \\
 &= u_{\langle b,c|\emptyset \rangle} - u_{\langle a,c|bd \rangle} + u_{\langle a,b|cd \rangle} \\
 &= (+2\delta_\emptyset - \delta_{\{b\}} - \delta_{\{c\}} - \delta_{\{d\}} + \delta_{\{c,d\}} - \delta_{\{a,c,d\}} + \delta_{\{a,b,c,d\}}) \\
 &\quad - (\delta_\emptyset - \delta_{\{d\}} - \delta_{\{b,c\}} + \delta_{\{b,d\}} - \delta_{\{a,b,d\}} + \delta_{\{a,b,c,d\}}) \\
 &= (\delta_\emptyset - \delta_{\{b\}} - \delta_{\{c\}} + \delta_{\{b,c\}} + \delta_{\{c,d\}} - \delta_{\{a,c,d\}} - \delta_{\{b,c,d\}} + \delta_{\{a,b,c,d\}}) \\
 &\quad - (\delta_{\{b,d\}} - \delta_{\{a,b,d\}} - \delta_{\{b,c,d\}} + \delta_{\{a,b,c,d\}})
 \end{aligned}$$

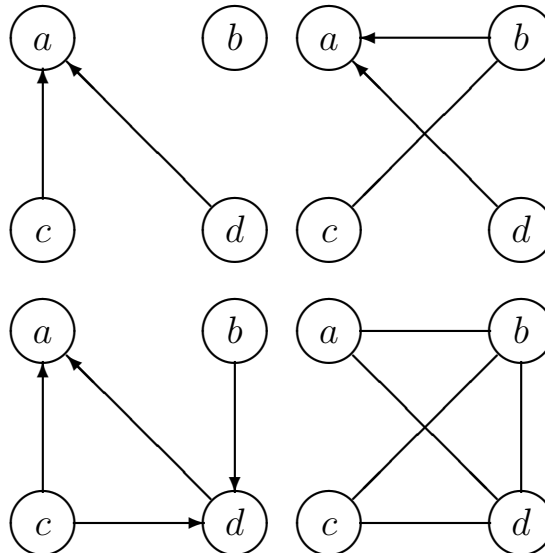



1.8.8.23 Differential imset (129)

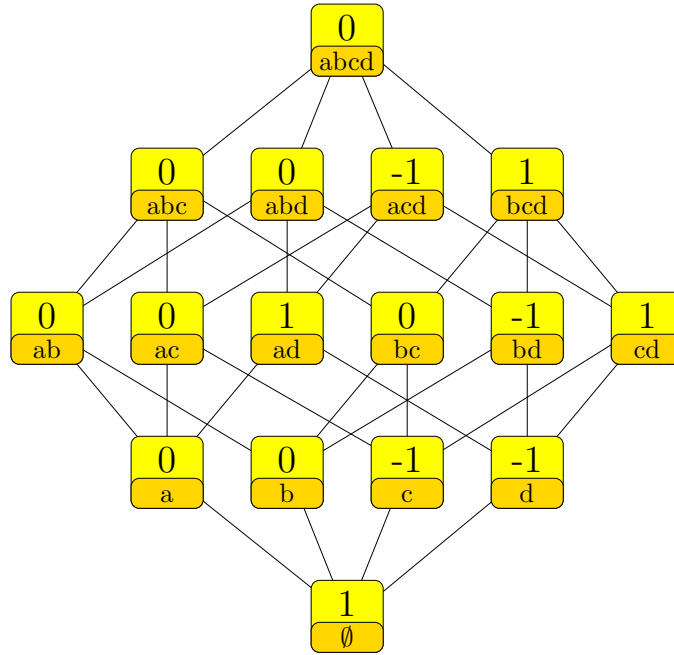

$$\begin{aligned}
 & \delta_{\emptyset} - \delta_{\{c\}} - \delta_{\{d\}} + \delta_{\{a,d\}} - \delta_{\{b,d\}} + \delta_{\{c,d\}} - \delta_{\{a,c,d\}} + \delta_{\{b,c,d\}} \\
 &= u_{\langle b,c|\emptyset \rangle} - u_{\langle a,c|d \rangle} + u_{\langle c,d|b \rangle} \\
 &= (+2\delta_{\emptyset} - \delta_{\{b\}} - \delta_{\{c\}} - \delta_{\{d\}} + \delta_{\{c,d\}} - \delta_{\{a,c,d\}} + \delta_{\{a,b,c,d\}}) \\
 &\quad - (\delta_{\emptyset} - \delta_{\{b\}} - \delta_{\{a,d\}} + \delta_{\{b,d\}} - \delta_{\{b,c,d\}} + \delta_{\{a,b,c,d\}})
 \end{aligned}$$

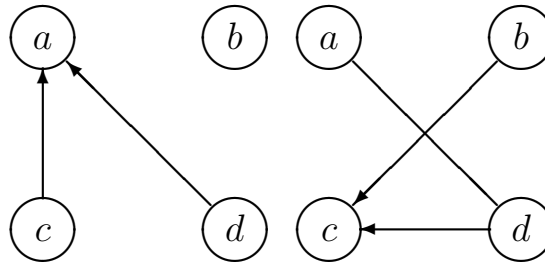

1.8.8.24 Differential imset (130)

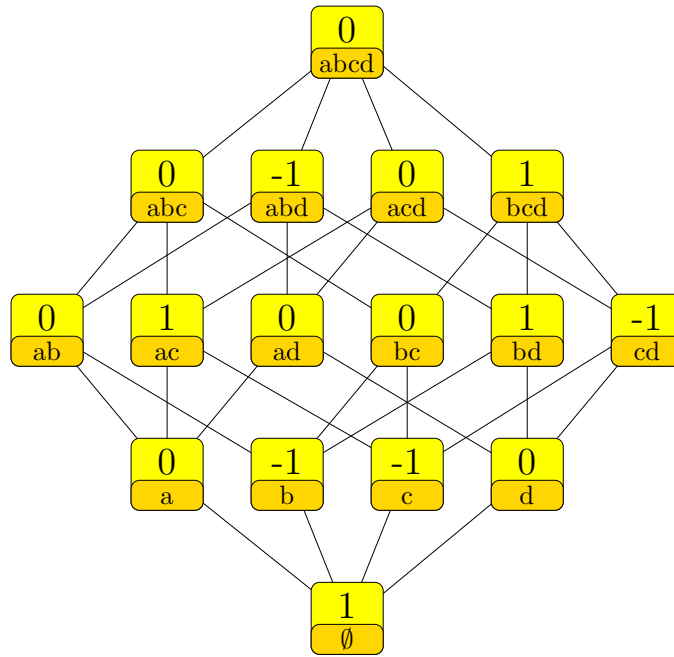

$$\begin{aligned}
 & \delta_\emptyset - \delta_{\{b\}} - \delta_{\{c\}} + \delta_{\{a,c\}} + \delta_{\{b,d\}} - \delta_{\{c,d\}} - \delta_{\{a,b,d\}} + \delta_{\{b,c,d\}} \\
 &= -u_{\langle a,b|\emptyset \rangle} + u_{\langle a,c|\emptyset \rangle} + u_{\langle b,c|\emptyset \rangle} - u_{\langle a,d|b \rangle} + u_{\langle b,d|c \rangle} \\
 &= (+2\delta_\emptyset - \delta_{\{b\}} - \delta_{\{c\}} - \delta_{\{d\}} + \delta_{\{b,d\}} - \delta_{\{a,b,d\}} + \delta_{\{a,b,c,d\}}) \\
 &\quad - (\delta_\emptyset - \delta_{\{d\}} - \delta_{\{a,c\}} + \delta_{\{c,d\}} - \delta_{\{b,c,d\}} + \delta_{\{a,b,c,d\}})
 \end{aligned}$$

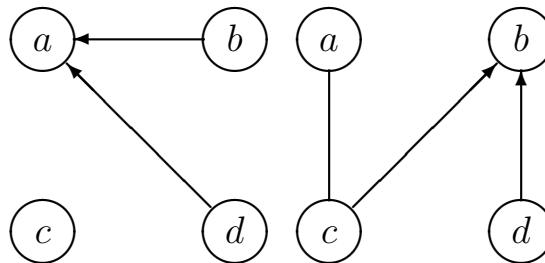

1.8.8.25 Differential imset (131)

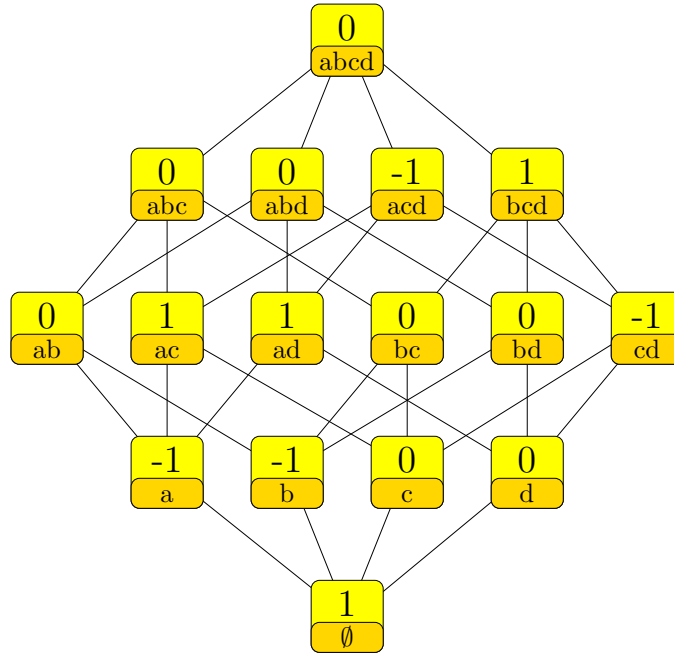

$$\begin{aligned}
 & \delta_\emptyset - \delta_{\{a\}} - \delta_{\{b\}} + \delta_{\{a,c\}} + \delta_{\{a,d\}} - \delta_{\{c,d\}} - \delta_{\{a,c,d\}} + \delta_{\{b,c,d\}} \\
 &= u_{\langle b,c|\emptyset \rangle} - u_{\langle c,d|a \rangle} + u_{\langle b,d|c \rangle} \\
 &= (+2\delta_\emptyset - \delta_{\{a\}} - \delta_{\{b\}} - \delta_{\{c\}} + \delta_{\{a,c\}} - \delta_{\{a,c,d\}} + \delta_{\{a,b,c,d\}}) \\
 &\quad - (\delta_\emptyset - \delta_{\{c\}} - \delta_{\{a,d\}} + \delta_{\{c,d\}} - \delta_{\{b,c,d\}} + \delta_{\{a,b,c,d\}}) \\
 &= (\delta_\emptyset - \delta_{\{b\}} - \delta_{\{a,c,d\}} + \delta_{\{a,b,c,d\}}) \\
 &\quad - (\delta_{\{a\}} - \delta_{\{a,c\}} - \delta_{\{a,d\}} + \delta_{\{c,d\}} - \delta_{\{b,c,d\}} + \delta_{\{a,b,c,d\}})
 \end{aligned}$$

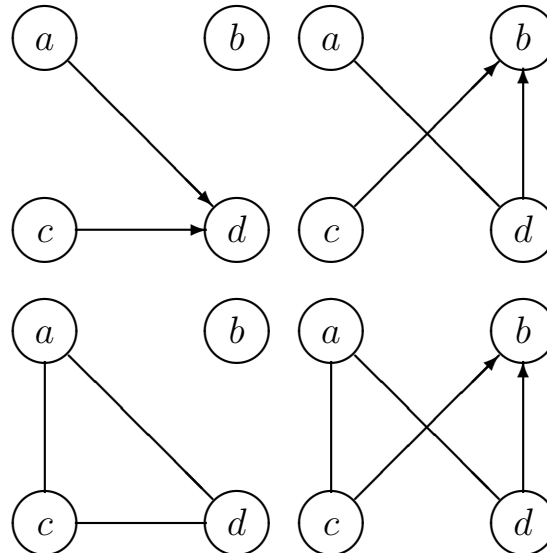

1.8.8.26 Differential imset (132)

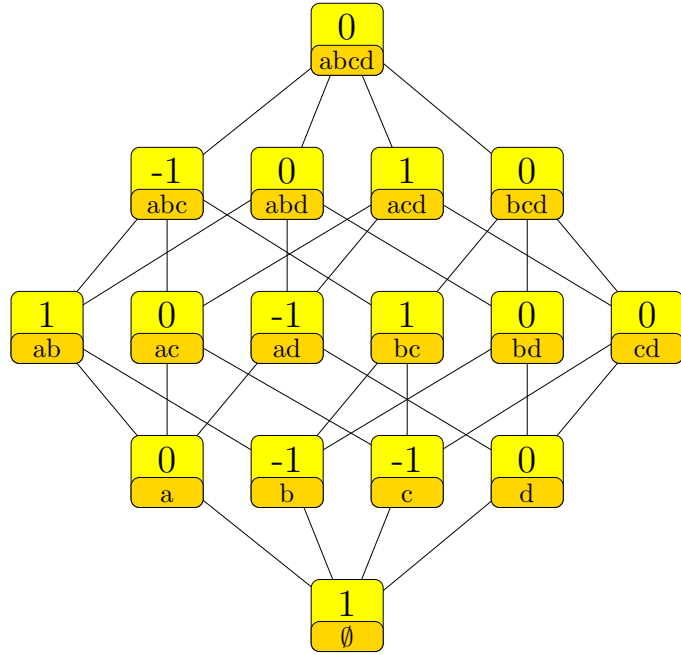

$$\begin{aligned}
 & \delta_\emptyset - \delta_{\{b\}} - \delta_{\{c\}} + \delta_{\{a,b\}} - \delta_{\{a,d\}} + \delta_{\{b,c\}} - \delta_{\{a,b,c\}} + \delta_{\{a,c,d\}} \\
 &= u_{\langle a,c|\emptyset \rangle} - u_{\langle a,c|b \rangle} + u_{\langle c,d|a \rangle} \\
 &= (+2\delta_\emptyset - \delta_{\{b\}} - \delta_{\{c\}} - \delta_{\{d\}} + \delta_{\{b,c\}} - \delta_{\{a,b,c\}} + \delta_{\{a,b,c,d\}}) \\
 &\quad - (\delta_\emptyset - \delta_{\{d\}} - \delta_{\{a,b\}} + \delta_{\{a,d\}} - \delta_{\{a,c,d\}} + \delta_{\{a,b,c,d\}}) \\
 &= (\delta_\emptyset - \delta_{\{b\}} + \delta_{\{a,b\}} - \delta_{\{a,d\}} - \delta_{\{a,b,c\}} + \delta_{\{a,b,c,d\}}) \\
 &\quad - (\delta_{\{c\}} - \delta_{\{b,c\}} - \delta_{\{a,c,d\}} + \delta_{\{a,b,c,d\}}) \\
 &= (\delta_\emptyset + \delta_{\{a\}} - \delta_{\{b\}} - \delta_{\{c\}} - \delta_{\{a,d\}} + \delta_{\{b,c\}} - \delta_{\{a,b,c\}} + \delta_{\{a,b,c,d\}}) \\
 &\quad - (\delta_{\{a\}} - \delta_{\{a,b\}} - \delta_{\{a,c,d\}} + \delta_{\{a,b,c,d\}}) \\
 &= (\delta_\emptyset - \delta_{\{b\}} - \delta_{\{c\}} + \delta_{\{a,b\}} + \delta_{\{b,c\}} - \delta_{\{a,b,c\}} - \delta_{\{a,b,d\}} + \delta_{\{a,b,c,d\}}) \\
 &\quad - (\delta_{\{a,d\}} - \delta_{\{a,b,d\}} - \delta_{\{a,c,d\}} + \delta_{\{a,b,c,d\}})
 \end{aligned}$$

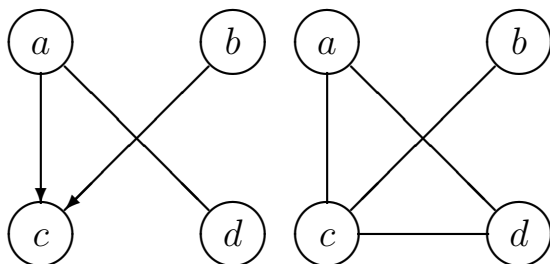
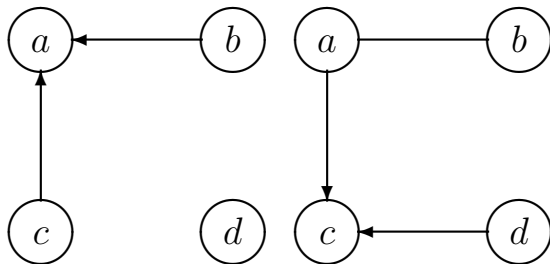

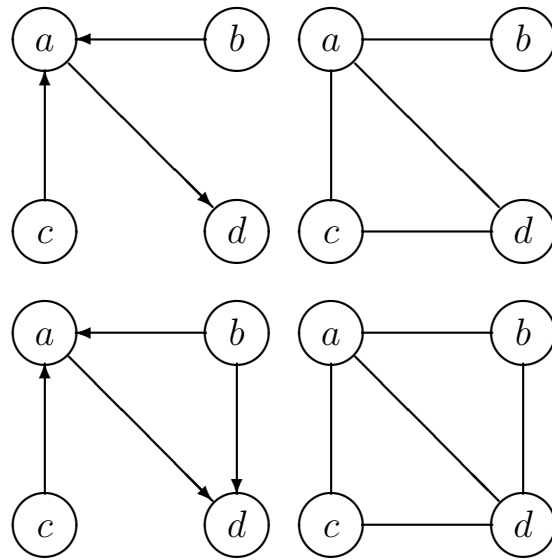

### 1.10 Squared Euclidean length 10

#### 1.10.7 Number of nonzero values 7

##### 1.10.7.1 Differential imset (133)

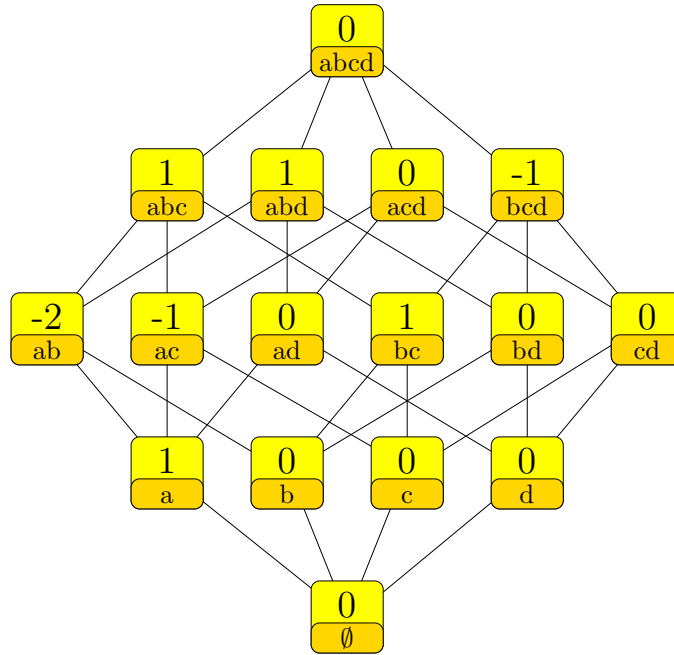

$$\begin{aligned}
 & \delta_{\{a\}} - 2\delta_{\{a,b\}} - \delta_{\{a,c\}} + \delta_{\{b,c\}} + \delta_{\{a,b,c\}} + \delta_{\{a,b,d\}} - \delta_{\{b,c,d\}} \\
 &= -u_{\langle c,d|ab \rangle} + u_{\langle a,d|bc \rangle} + u_{\langle b,c|a \rangle} \\
 &= (\delta_{\emptyset} - \delta_{\{c\}} - \delta_{\{a,b\}} + \delta_{\{b,c\}} - \delta_{\{b,c,d\}} + \delta_{\{a,b,c,d\}}) \\
 &\quad - (\delta_{\emptyset} - \delta_{\{a\}} - \delta_{\{c\}} + \delta_{\{a,b\}} + \delta_{\{a,c\}} - \delta_{\{a,b,c\}} - \delta_{\{a,b,d\}} + \delta_{\{a,b,c,d\}}) \\
 &= (\delta_{\{a\}} - \delta_{\{a,b\}} - \delta_{\{a,c\}} + \delta_{\{b,c\}} - \delta_{\{b,c,d\}} + \delta_{\{a,b,c,d\}}) \\
 &\quad - (\delta_{\{a,b\}} - \delta_{\{a,b,c\}} - \delta_{\{a,b,d\}} + \delta_{\{a,b,c,d\}})
 \end{aligned}$$

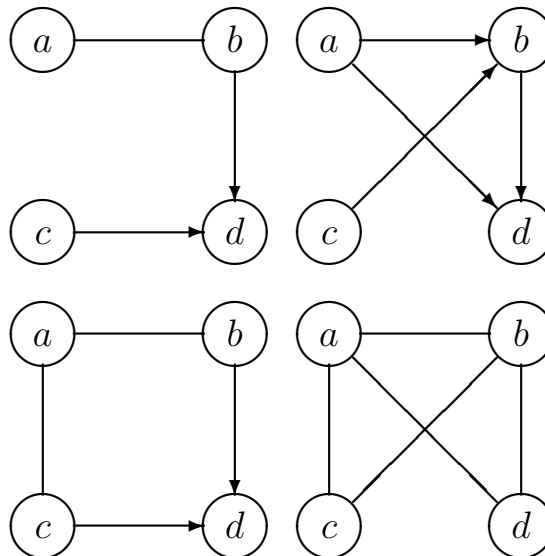

1.10.7.2 Differential imset (134)

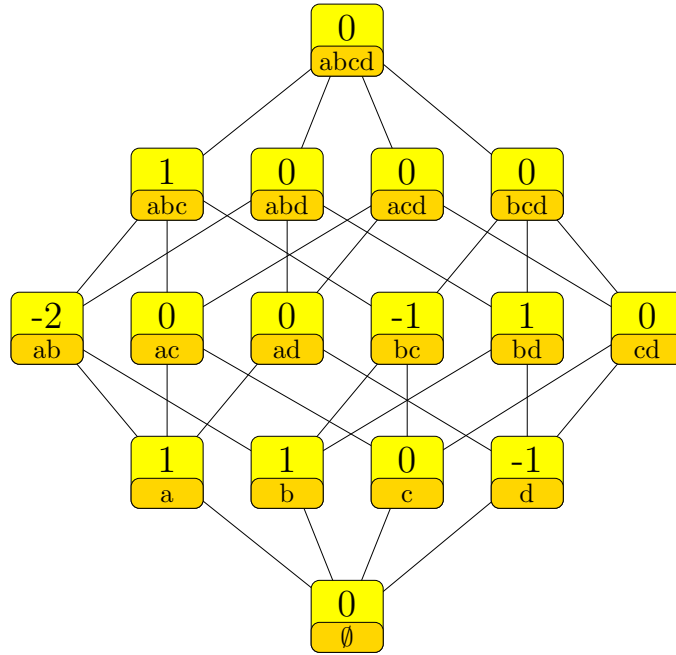

$$\begin{aligned}
 & \delta_{\{a\}} + \delta_{\{b\}} - \delta_{\{d\}} - 2\delta_{\{a,b\}} - \delta_{\{b,c\}} + \delta_{\{b,d\}} + \delta_{\{a,b,c\}} \\
 &= -u_{\langle a,b|\emptyset \rangle} + u_{\langle b,d|\emptyset \rangle} + u_{\langle a,c|b \rangle} \\
 &= (\delta_{\emptyset} + \delta_{\{b\}} - \delta_{\{d\}} - \delta_{\{a,b\}} - \delta_{\{b,c\}} + \delta_{\{a,b,c,d\}}) \\
 &\quad - (\delta_{\emptyset} - \delta_{\{a\}} + \delta_{\{a,b\}} - \delta_{\{b,d\}} - \delta_{\{a,b,c\}} + \delta_{\{a,b,c,d\}}) \\
 &= (\delta_{\{a\}} + \delta_{\{b\}} - \delta_{\{a,b\}} - \delta_{\{a,d\}} - \delta_{\{b,c\}} + \delta_{\{a,b,c,d\}}) \\
 &\quad - (\delta_{\{d\}} + \delta_{\{a,b\}} - \delta_{\{a,d\}} - \delta_{\{b,d\}} - \delta_{\{a,b,c\}} + \delta_{\{a,b,c,d\}}) \\
 &= (\delta_{\emptyset} - \delta_{\{d\}} - \delta_{\{b,c\}} + \delta_{\{b,d\}} - \delta_{\{a,b,d\}} + \delta_{\{a,b,c,d\}}) \\
 &\quad - (\delta_{\emptyset} - \delta_{\{a\}} - \delta_{\{b\}} + 2\delta_{\{a,b\}} - \delta_{\{a,b,c\}} - \delta_{\{a,b,d\}} + \delta_{\{a,b,c,d\}})
 \end{aligned}$$

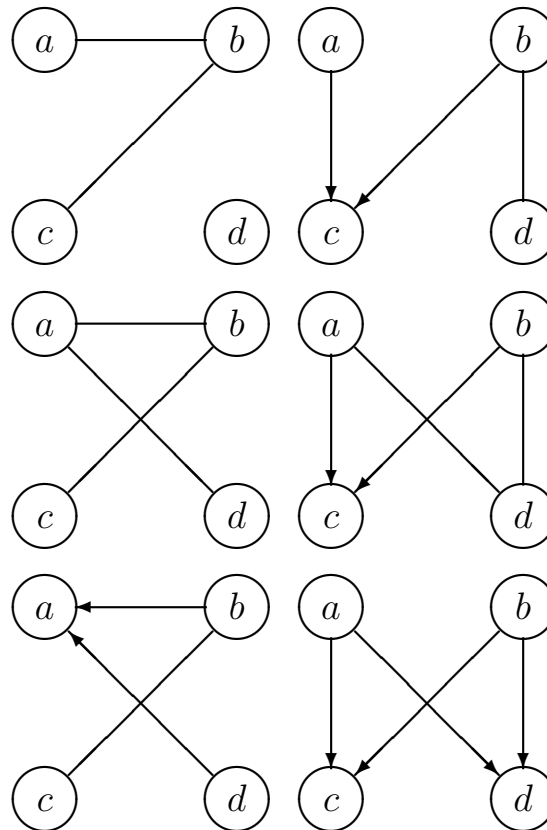

1.10.7.3 Differential imset (135)

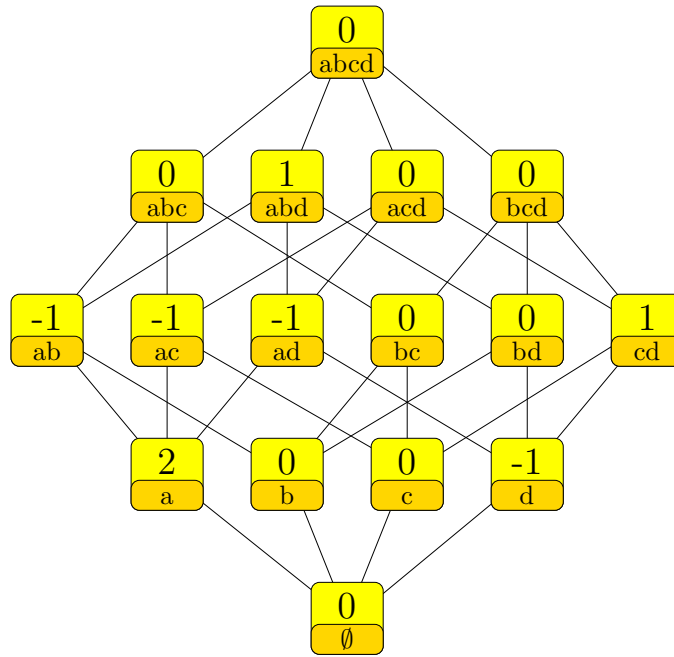

$$\begin{aligned}
 &+2\delta_{\{a\}} - \delta_{\{d\}} - \delta_{\{a,b\}} - \delta_{\{a,c\}} - \delta_{\{a,d\}} + \delta_{\{c,d\}} + \delta_{\{a,b,d\}} \\
 &= -u_{\langle a,c|\emptyset\rangle} + u_{\langle c,d|\emptyset\rangle} + u_{\langle b,d|a\rangle} \\
 &= (\delta_{\emptyset} + \delta_{\{a\}} - \delta_{\{b\}} - \delta_{\{a,c\}} - \delta_{\{a,d\}} + \delta_{\{a,b,c,d\}}) \\
 &\quad - (\delta_{\emptyset} - \delta_{\{a\}} - \delta_{\{b\}} + \delta_{\{d\}} + \delta_{\{a,b\}} - \delta_{\{c,d\}} - \delta_{\{a,b,d\}} + \delta_{\{a,b,c,d\}})
 \end{aligned}$$

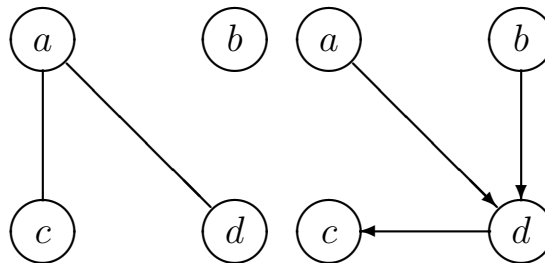



1.10.7.4 Differential imset (136)

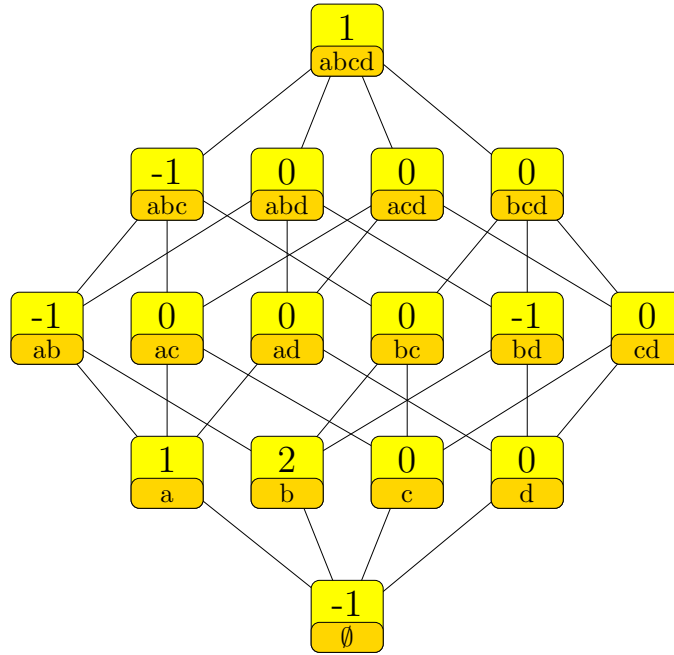

$$\begin{aligned}
 & -\delta_{\emptyset} + \delta_{\{a\}} + 2\delta_{\{b\}} - \delta_{\{a,b\}} - \delta_{\{b,d\}} - \delta_{\{a,b,c\}} + \delta_{\{a,b,c,d\}} \\
 &= -u_{\langle a,b|\emptyset \rangle} + u_{\langle c,d|ab \rangle} + u_{\langle a,d|b \rangle} \\
 &= (\delta_{\emptyset} + \delta_{\{b\}} - \delta_{\{c\}} - \delta_{\{a,b\}} - \delta_{\{b,d\}} + \delta_{\{a,b,c,d\}}) \\
 &\quad - (+2\delta_{\emptyset} - \delta_{\{a\}} - \delta_{\{b\}} - \delta_{\{c\}} + \delta_{\{a,b,c\}}) \\
 &= (+2\delta_{\{b\}} - \delta_{\{a,b\}} - \delta_{\{b,c\}} - \delta_{\{b,d\}} + \delta_{\{a,b,c,d\}}) \\
 &\quad - (\delta_{\emptyset} - \delta_{\{a\}} - \delta_{\{b,c\}} + \delta_{\{a,b,c\}}) \\
 &= (\delta_{\{b\}} - \delta_{\{b,d\}} - \delta_{\{a,b,c\}} + \delta_{\{a,b,c,d\}}) \\
 &\quad - (\delta_{\emptyset} - \delta_{\{a\}} - \delta_{\{b\}} + \delta_{\{a,b\}})
 \end{aligned}$$

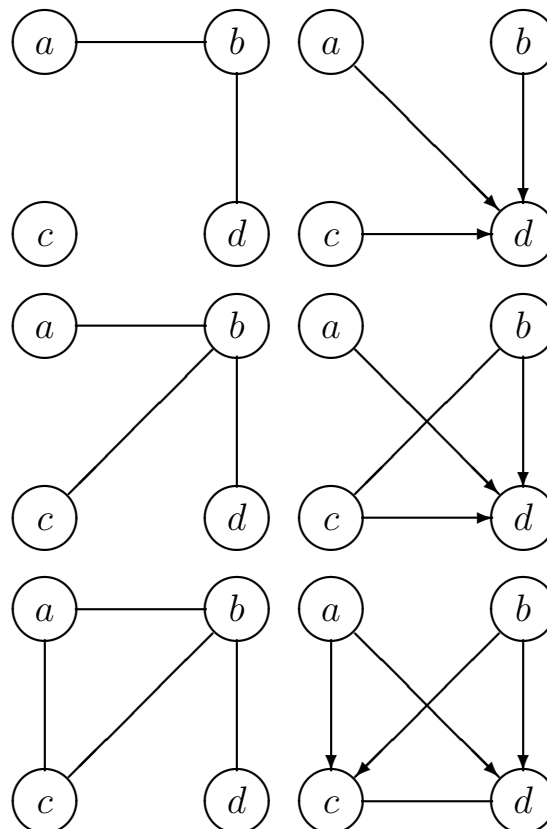

1.10.7.5 Differential imset (137)

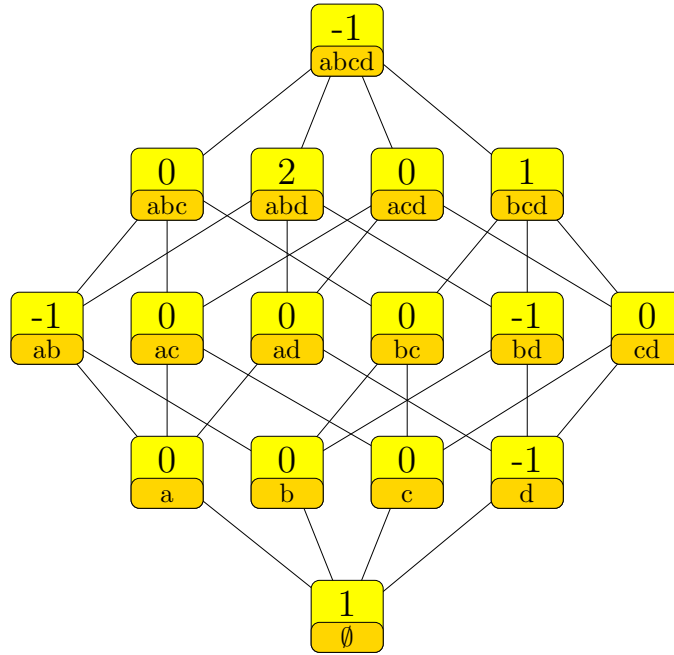

$$\begin{aligned}
 & \delta_\emptyset - \delta_{\{d\}} - \delta_{\{a,b\}} - \delta_{\{b,d\}} + 2\delta_{\{a,b,d\}} + \delta_{\{b,c,d\}} - \delta_{\{a,b,c,d\}} \\
 &= u_{\langle a,d|\emptyset \rangle} - u_{\langle a,c|bd \rangle} + u_{\langle b,d|a \rangle} \\
 &= (+2\delta_\emptyset - \delta_{\{a\}} - \delta_{\{b\}} - \delta_{\{d\}} + \delta_{\{a,b,d\}}) \\
 &\quad - (\delta_\emptyset - \delta_{\{a\}} - \delta_{\{b\}} + \delta_{\{a,b\}} + \delta_{\{b,d\}} - \delta_{\{a,b,d\}} - \delta_{\{b,c,d\}} + \delta_{\{a,b,c,d\}}) \\
 &= (\delta_\emptyset - \delta_{\{d\}} - \delta_{\{a,b\}} + \delta_{\{a,b,d\}}) \\
 &\quad - (\delta_{\{b,d\}} - \delta_{\{a,b,d\}} - \delta_{\{b,c,d\}} + \delta_{\{a,b,c,d\}})
 \end{aligned}$$

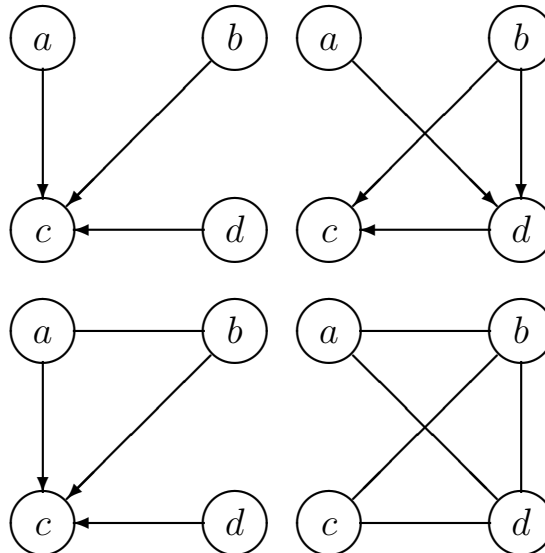

1.10.7.6 Differential imset (138)

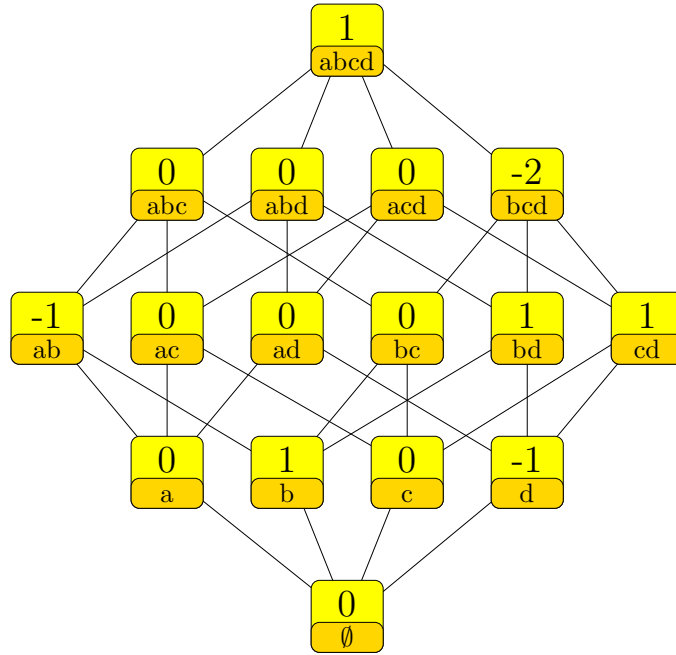

$$\begin{aligned}
 & \delta_{\{b\}} - \delta_{\{d\}} - \delta_{\{a,b\}} + \delta_{\{b,d\}} + \delta_{\{c,d\}} - 2\delta_{\{b,c,d\}} + \delta_{\{a,b,c,d\}} \\
 &= u_{\langle a,d|bc \rangle} + u_{\langle a,c|b \rangle} - u_{\langle b,c|d \rangle} \\
 &= (\delta_{\emptyset} + \delta_{\{b\}} - \delta_{\{c\}} - \delta_{\{d\}} - \delta_{\{a,b\}} + \delta_{\{c,d\}} - \delta_{\{b,c,d\}} + \delta_{\{a,b,c,d\}}) \\
 &\quad - (\delta_{\emptyset} - \delta_{\{c\}} - \delta_{\{b,d\}} + \delta_{\{b,c,d\}})
 \end{aligned}$$

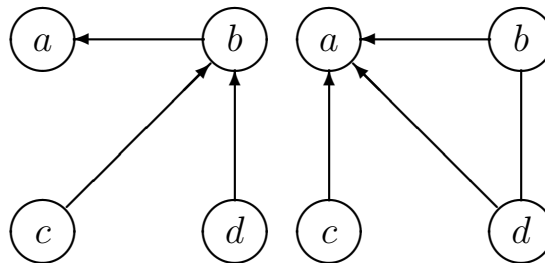

1.10.7.7 Differential imset (139)

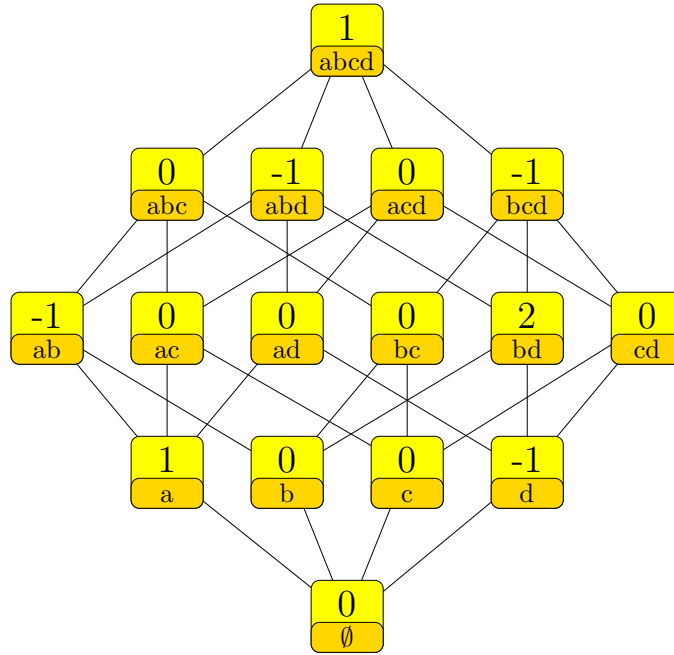

$$\begin{aligned}
 & \delta_{\{a\}} - \delta_{\{d\}} - \delta_{\{a,b\}} + 2\delta_{\{b,d\}} - \delta_{\{a,b,d\}} - \delta_{\{b,c,d\}} + \delta_{\{a,b,c,d\}} \\
 &= -u_{\langle a,b|\emptyset \rangle} + u_{\langle b,d|\emptyset \rangle} + u_{\langle a,c|bd \rangle} \\
 &= (\delta_{\emptyset} - \delta_{\{d\}} - \delta_{\{a,b\}} + \delta_{\{b,d\}} - \delta_{\{b,c,d\}} + \delta_{\{a,b,c,d\}}) \\
 &\quad - (\delta_{\emptyset} - \delta_{\{a\}} - \delta_{\{b,d\}} + \delta_{\{a,b,d\}}) \\
 &= (\delta_{\emptyset} - \delta_{\{b\}} - \delta_{\{d\}} + 2\delta_{\{b,d\}} - \delta_{\{a,b,d\}} - \delta_{\{b,c,d\}} + \delta_{\{a,b,c,d\}}) \\
 &\quad - (\delta_{\emptyset} - \delta_{\{a\}} - \delta_{\{b\}} + \delta_{\{a,b\}})
 \end{aligned}$$

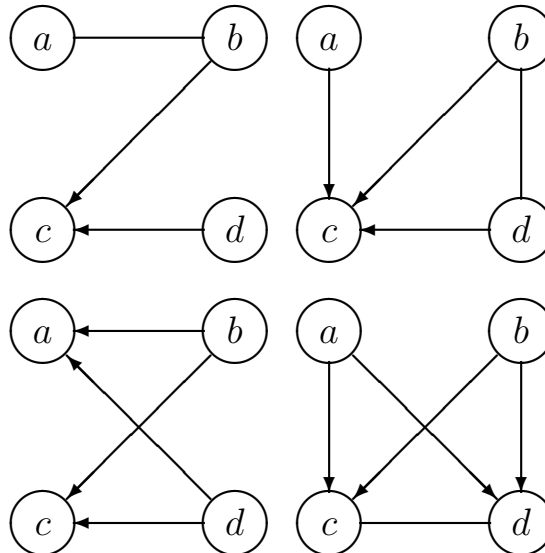

1.10.7.8 Differential imset (140)

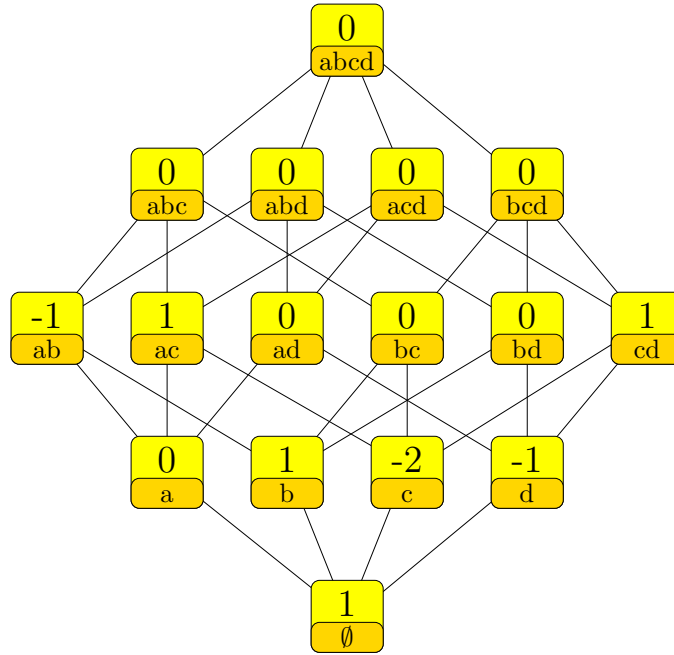

$$\begin{aligned}
 & \delta_\emptyset + \delta_{\{b\}} - 2\delta_{\{c\}} - \delta_{\{d\}} - \delta_{\{a,b\}} + \delta_{\{a,c\}} + \delta_{\{c,d\}} \\
 &= -u_{\langle a,b|\emptyset \rangle} + u_{\langle a,c|\emptyset \rangle} + u_{\langle c,d|\emptyset \rangle} \\
 &= (+2\delta_\emptyset - \delta_{\{c\}} - \delta_{\{d\}} - \delta_{\{a,b\}} + \delta_{\{a,b,c,d\}}) \\
 &\quad - (\delta_\emptyset - \delta_{\{b\}} + \delta_{\{c\}} - \delta_{\{a,c\}} - \delta_{\{c,d\}} + \delta_{\{a,b,c,d\}}) \\
 &= (+2\delta_\emptyset - \delta_{\{a\}} - \delta_{\{c\}} - \delta_{\{d\}} + \delta_{\{a,c\}} - \delta_{\{a,b,c\}} + \delta_{\{a,b,c,d\}}) \\
 &\quad - (\delta_\emptyset - \delta_{\{a\}} - \delta_{\{b\}} + \delta_{\{c\}} + \delta_{\{a,b\}} - \delta_{\{c,d\}} - \delta_{\{a,b,c\}} + \delta_{\{a,b,c,d\}})
 \end{aligned}$$

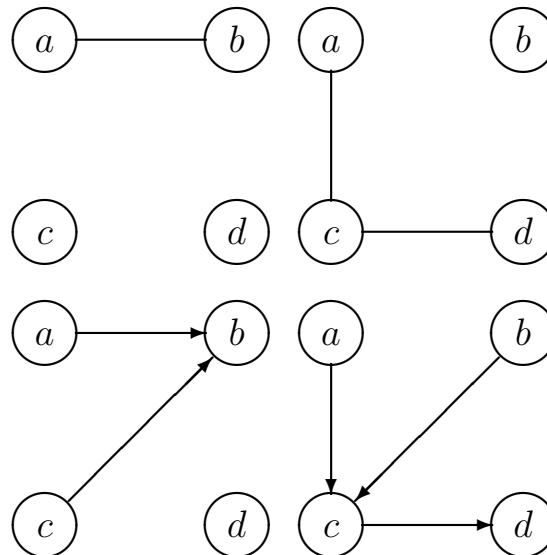

1.10.7.9 Differential imset (141)

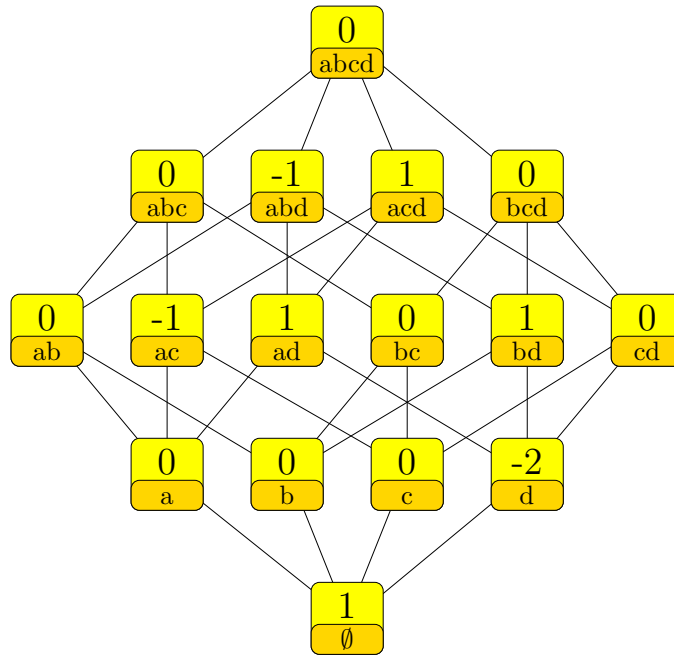

$$\begin{aligned}
 & \delta_\emptyset - 2\delta_{\{d\}} - \delta_{\{a,c\}} + \delta_{\{a,d\}} + \delta_{\{b,d\}} - \delta_{\{a,b,d\}} + \delta_{\{a,c,d\}} \\
 &= u_{\langle a,d|\emptyset \rangle} + u_{\langle c,d|a \rangle} - u_{\langle a,b|d \rangle} \\
 &= (\delta_\emptyset - \delta_{\{d\}} - \delta_{\{a,c\}} + \delta_{\{a,d\}} - \delta_{\{a,b,d\}} + \delta_{\{a,b,c,d\}}) \\
 &\quad - (\delta_{\{d\}} - \delta_{\{b,d\}} - \delta_{\{a,c,d\}} + \delta_{\{a,b,c,d\}})
 \end{aligned}$$

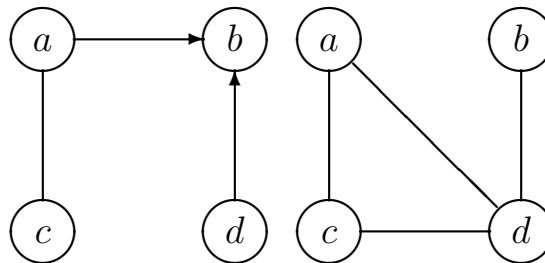

1.10.7.10 Differential imset (142)

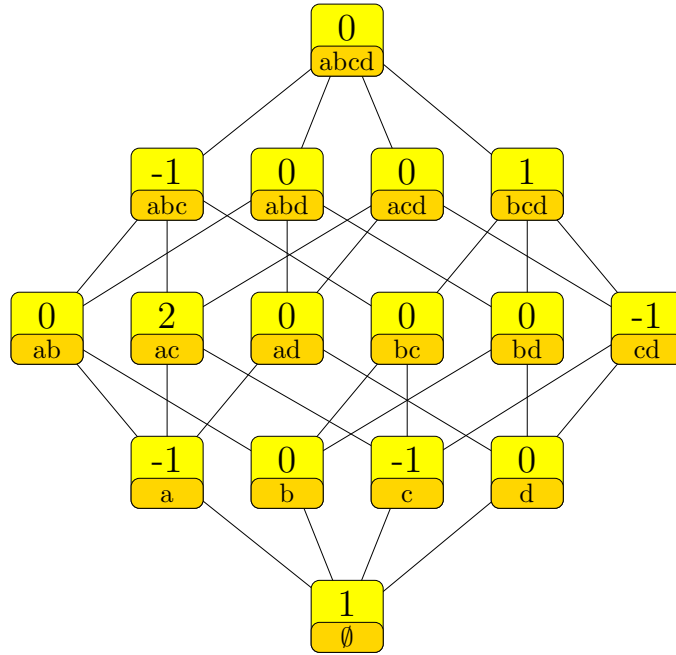

$$\begin{aligned}
 & \delta_\emptyset - \delta_{\{a\}} - \delta_{\{c\}} + 2\delta_{\{a,c\}} - \delta_{\{c,d\}} - \delta_{\{a,b,c\}} + \delta_{\{b,c,d\}} \\
 &= u_{\langle a,c|\emptyset \rangle} + u_{\langle b,d|ac \rangle} - u_{\langle a,b|cd \rangle} \\
 &= (+2\delta_\emptyset - \delta_{\{a\}} - \delta_{\{c\}} - \delta_{\{d\}} + \delta_{\{a,c\}} - \delta_{\{a,b,c\}} + \delta_{\{a,b,c,d\}}) \\
 &\quad - (\delta_\emptyset - \delta_{\{d\}} - \delta_{\{a,c\}} + \delta_{\{c,d\}} - \delta_{\{b,c,d\}} + \delta_{\{a,b,c,d\}}) \\
 &= (\delta_\emptyset - \delta_{\{a\}} - \delta_{\{c\}} + 2\delta_{\{a,c\}} - \delta_{\{a,b,c\}} - \delta_{\{a,c,d\}} + \delta_{\{a,b,c,d\}}) \\
 &\quad - (\delta_{\{c,d\}} - \delta_{\{a,c,d\}} - \delta_{\{b,c,d\}} + \delta_{\{a,b,c,d\}})
 \end{aligned}$$

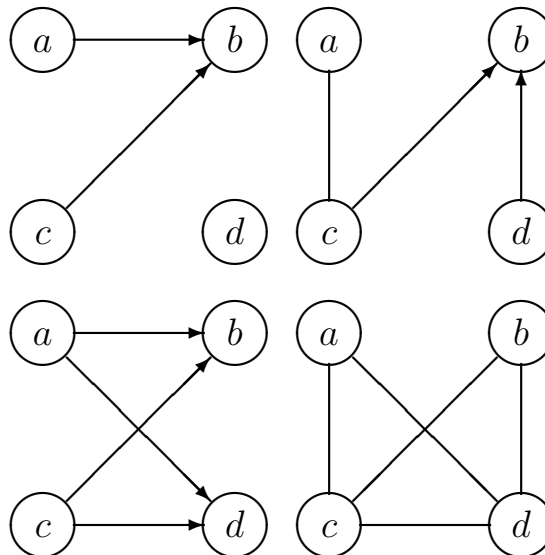

1.10.10 Number of nonzero values 10

1.10.10.1 Differential imset (143)

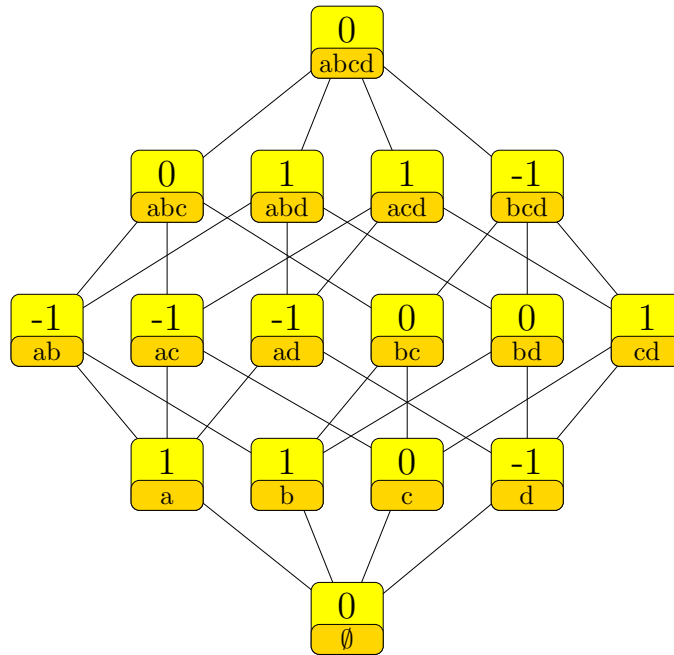

$$\begin{aligned}
 & \delta_{\{a\}} + \delta_{\{b\}} - \delta_{\{d\}} - \delta_{\{a,b\}} - \delta_{\{a,c\}} - \delta_{\{a,d\}} + \delta_{\{c,d\}} + \delta_{\{a,b,d\}} + \delta_{\{a,c,d\}} - \delta_{\{b,c,d\}} \\
 &= u_{\langle a,d|b \rangle} + u_{\langle c,d|a \rangle} - u_{\langle b,c|d \rangle} \\
 &= (\delta_{\emptyset} - \delta_{\{d\}} - \delta_{\{a,c\}} + \delta_{\{c,d\}} - \delta_{\{b,c,d\}} + \delta_{\{a,b,c,d\}}) \\
 &\quad - (\delta_{\emptyset} - \delta_{\{a\}} - \delta_{\{b\}} + \delta_{\{a,b\}} + \delta_{\{a,d\}} - \delta_{\{a,b,d\}} - \delta_{\{a,c,d\}} + \delta_{\{a,b,c,d\}})
 \end{aligned}$$

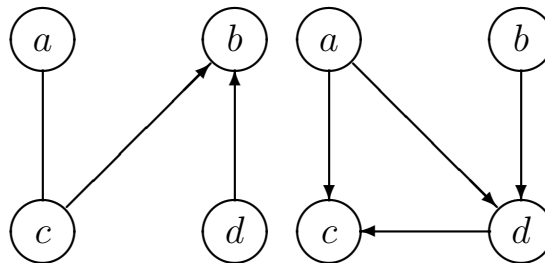



1.10.10.2 Differential imset (144)

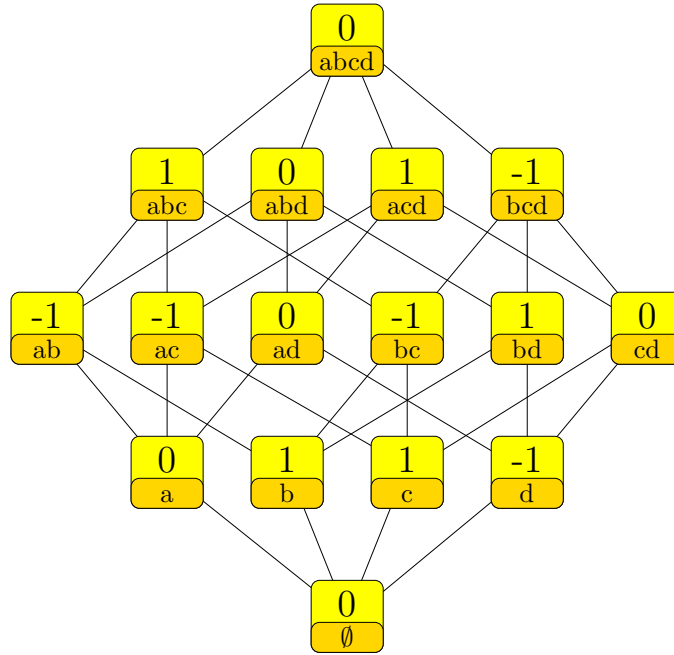

$$\begin{aligned}
 & \delta_{\{b\}} + \delta_{\{c\}} - \delta_{\{d\}} - \delta_{\{a,b\}} - \delta_{\{a,c\}} - \delta_{\{b,c\}} + \delta_{\{b,d\}} + \delta_{\{a,b,c\}} + \delta_{\{a,c,d\}} - \delta_{\{b,c,d\}} \\
 &= u_{\langle a,c|b \rangle} + u_{\langle a,d|c \rangle} - u_{\langle b,c|d \rangle} \\
 &= (\delta_{\emptyset} - \delta_{\{d\}} - \delta_{\{a,b\}} + \delta_{\{b,d\}} - \delta_{\{b,c,d\}} + \delta_{\{a,b,c,d\}}) \\
 &\quad - (\delta_{\emptyset} - \delta_{\{b\}} - \delta_{\{c\}} + \delta_{\{a,c\}} + \delta_{\{b,c\}} - \delta_{\{a,b,c\}} - \delta_{\{a,c,d\}} + \delta_{\{a,b,c,d\}})
 \end{aligned}$$

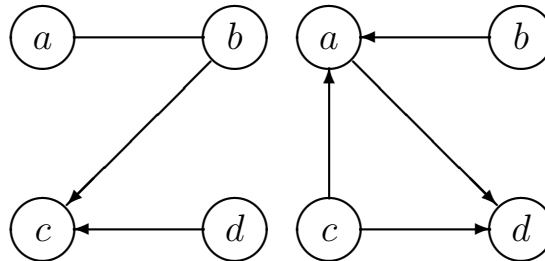

1.10.10.3 Differential imset (145)

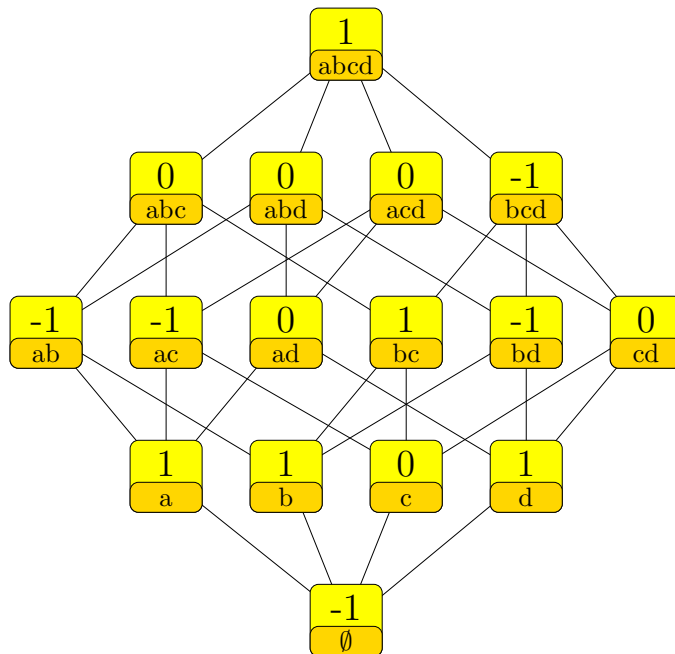

$$\begin{aligned}
 & -\delta_{\emptyset} + \delta_{\{a\}} + \delta_{\{b\}} + \delta_{\{d\}} - \delta_{\{a,b\}} - \delta_{\{a,c\}} + \delta_{\{b,c\}} - \delta_{\{b,d\}} - \delta_{\{b,c,d\}} + \delta_{\{a,b,c,d\}} \\
 &= -u_{\langle b,d|\emptyset \rangle} + u_{\langle a,d|bc \rangle} + u_{\langle b,c|a \rangle} \\
 &= (\delta_{\{a\}} + \delta_{\{b\}} - \delta_{\{a,b\}} - \delta_{\{a,c\}} - \delta_{\{b,d\}} + \delta_{\{a,b,c,d\}}) \\
 &\quad - (\delta_{\emptyset} - \delta_{\{d\}} - \delta_{\{b,c\}} + \delta_{\{b,c,d\}})
 \end{aligned}$$

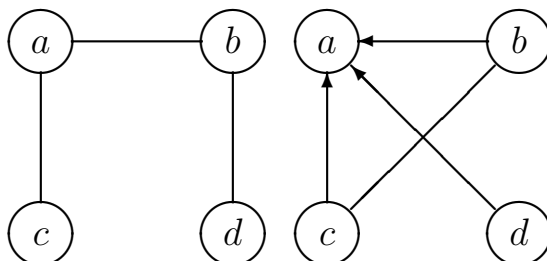

1.10.10.4 Differential imset (146)

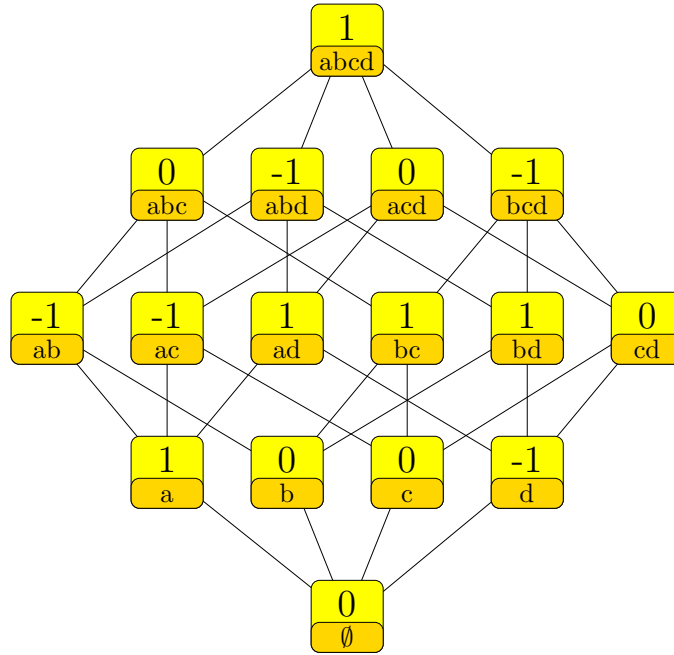

$$\begin{aligned}
 & \delta_{\{a\}} - \delta_{\{d\}} - \delta_{\{a,b\}} - \delta_{\{a,c\}} + \delta_{\{a,d\}} + \delta_{\{b,c\}} + \delta_{\{b,d\}} - \delta_{\{a,b,d\}} - \delta_{\{b,c,d\}} + \delta_{\{a,b,c,d\}} \\
 &= u_{\langle a,d|bc \rangle} + u_{\langle b,c|a \rangle} - u_{\langle a,b|d \rangle} \\
 &= (\delta_{\{a\}} - \delta_{\{a,b\}} - \delta_{\{a,c\}} + \delta_{\{b,c\}} - \delta_{\{b,c,d\}} + \delta_{\{a,b,c,d\}}) \\
 &\quad - (\delta_{\{d\}} - \delta_{\{a,d\}} - \delta_{\{b,d\}} + \delta_{\{a,b,d\}})
 \end{aligned}$$

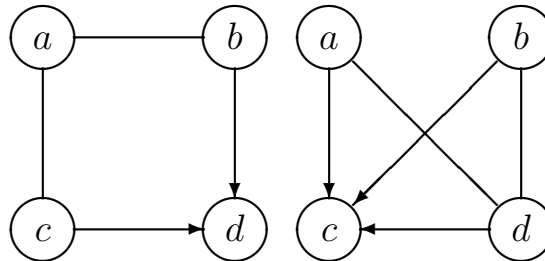

1.10.10.5 Differential imset (147)

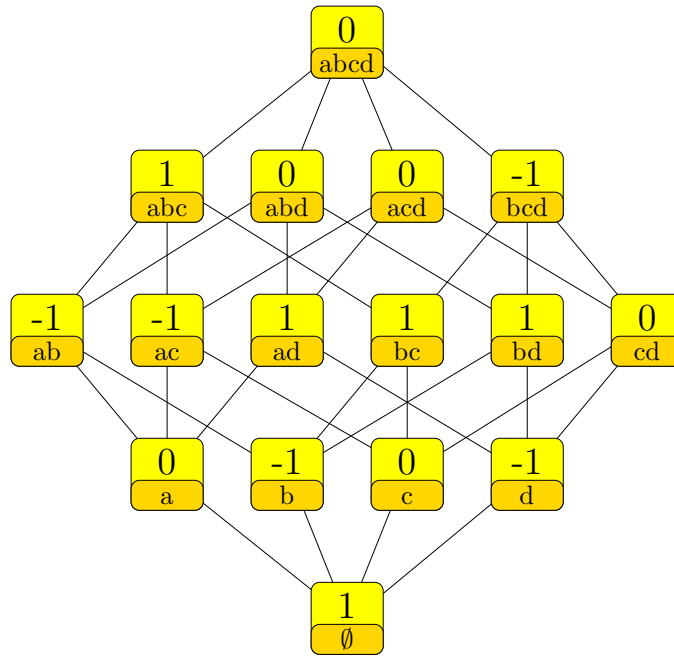

$$\begin{aligned}
 & \delta_\emptyset - \delta_{\{b\}} - \delta_{\{d\}} - \delta_{\{a,b\}} - \delta_{\{a,c\}} + \delta_{\{a,d\}} + \delta_{\{b,c\}} + \delta_{\{b,d\}} + \delta_{\{a,b,c\}} - \delta_{\{b,c,d\}} \\
 &= u_{\langle a,d|\emptyset \rangle} + u_{\langle b,c|a \rangle} - u_{\langle c,d|b \rangle} \\
 &= (\delta_\emptyset - \delta_{\{b\}} - \delta_{\{a,c\}} + \delta_{\{b,c\}} - \delta_{\{b,c,d\}} + \delta_{\{a,b,c,d\}}) \\
 &\quad - (\delta_{\{d\}} + \delta_{\{a,b\}} - \delta_{\{a,d\}} - \delta_{\{b,d\}} - \delta_{\{a,b,c\}} + \delta_{\{a,b,c,d\}})
 \end{aligned}$$

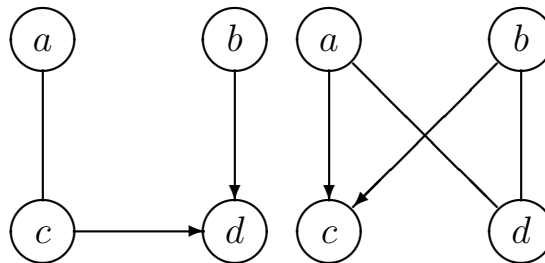

1.10.10.6 Differential imset (148)

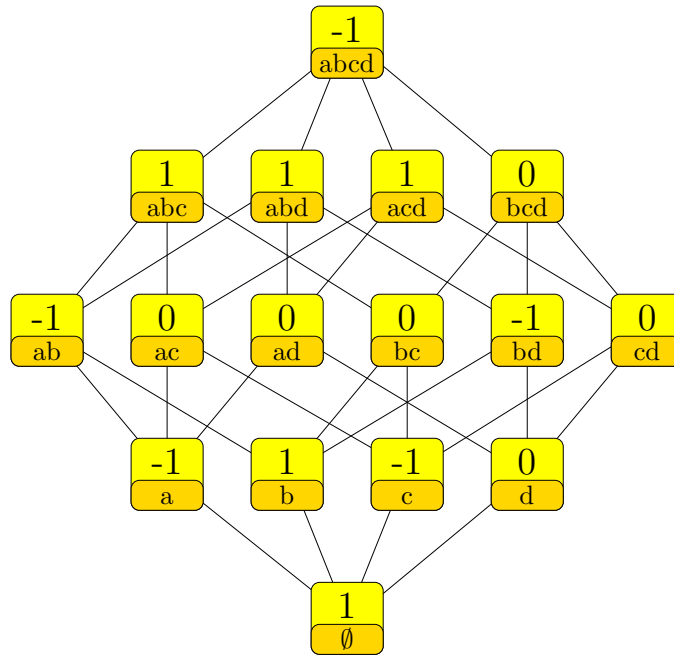

$$\begin{aligned}
 & \delta_\emptyset - \delta_{\{a\}} + \delta_{\{b\}} - \delta_{\{c\}} - \delta_{\{a,b\}} - \delta_{\{b,d\}} + \delta_{\{a,b,c\}} + \delta_{\{a,b,d\}} + \delta_{\{a,c,d\}} - \delta_{\{a,b,c,d\}} \\
 &= u_{\langle a,c|\emptyset \rangle} - u_{\langle b,d|ac \rangle} + u_{\langle a,d|b \rangle} \\
 &= (+2\delta_\emptyset - \delta_{\{a\}} - \delta_{\{c\}} - \delta_{\{d\}} + \delta_{\{a,c,d\}}) \\
 &\quad - (\delta_\emptyset - \delta_{\{b\}} - \delta_{\{d\}} + \delta_{\{a,b\}} + \delta_{\{b,d\}} - \delta_{\{a,b,c\}} - \delta_{\{a,b,d\}} + \delta_{\{a,b,c,d\}})
 \end{aligned}$$

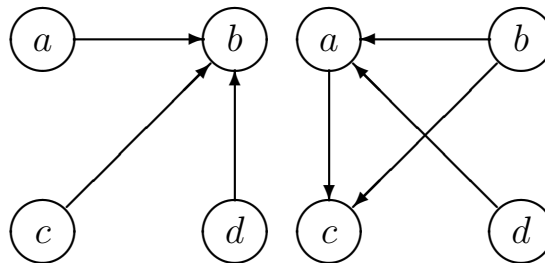

1.10.10.7 Differential imset (149)

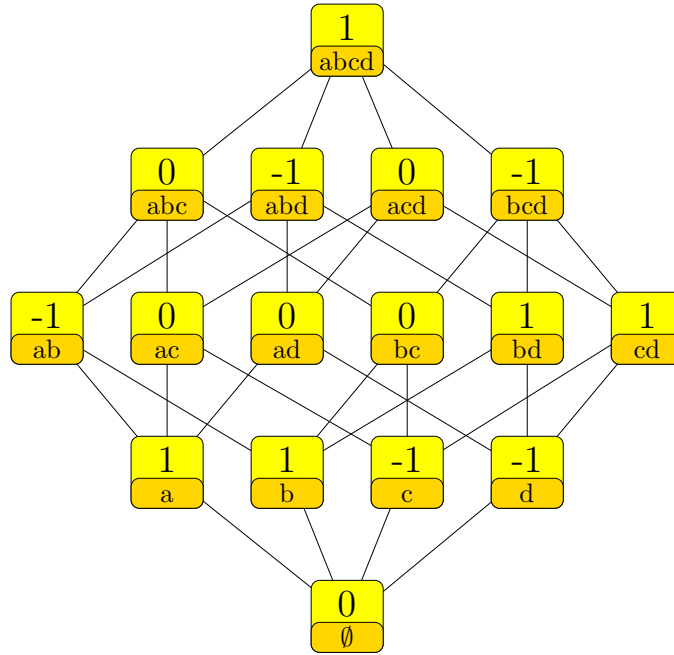

$$\begin{aligned}
 & \delta_{\{a\}} + \delta_{\{b\}} - \delta_{\{c\}} - \delta_{\{d\}} - \delta_{\{a,b\}} + \delta_{\{b,d\}} + \delta_{\{c,d\}} - \delta_{\{a,b,d\}} - \delta_{\{b,c,d\}} + \delta_{\{a,b,c,d\}} \\
 &= -u_{\langle a,b|\emptyset \rangle} + u_{\langle c,d|\emptyset \rangle} + u_{\langle a,c|bd \rangle} \\
 &= (\delta_{\emptyset} + \delta_{\{b\}} - \delta_{\{c\}} - \delta_{\{d\}} - \delta_{\{a,b\}} + \delta_{\{c,d\}} - \delta_{\{b,c,d\}} + \delta_{\{a,b,c,d\}}) \\
 &\quad - (\delta_{\emptyset} - \delta_{\{a\}} - \delta_{\{b,d\}} + \delta_{\{a,b,d\}}) \\
 &= (\delta_{\emptyset} - \delta_{\{c\}} - \delta_{\{d\}} + \delta_{\{b,d\}} + \delta_{\{c,d\}} - \delta_{\{a,b,d\}} - \delta_{\{b,c,d\}} + \delta_{\{a,b,c,d\}}) \\
 &\quad - (\delta_{\emptyset} - \delta_{\{a\}} - \delta_{\{b\}} + \delta_{\{a,b\}})
 \end{aligned}$$

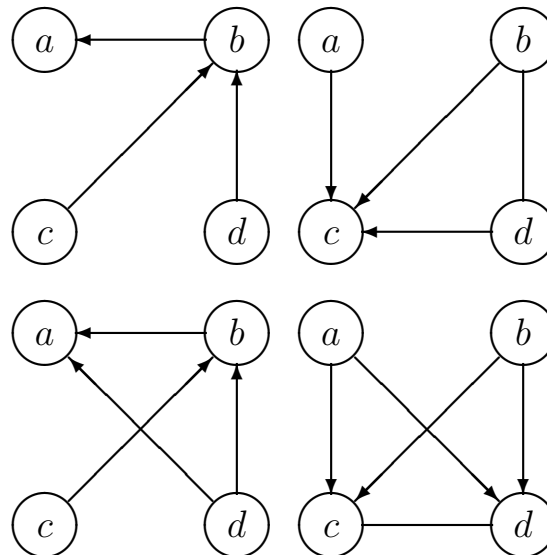

1.10.10.8 Differential imset (150)

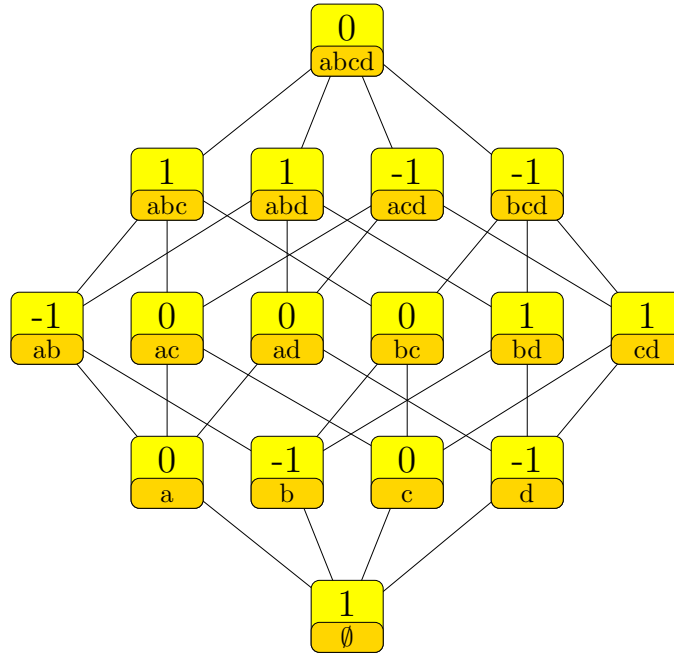

$$\begin{aligned}
 & \delta_\emptyset - \delta_{\{b\}} - \delta_{\{d\}} - \delta_{\{a,b\}} + \delta_{\{b,d\}} + \delta_{\{c,d\}} + \delta_{\{a,b,c\}} + \delta_{\{a,b,d\}} - \delta_{\{a,c,d\}} - \delta_{\{b,c,d\}} \\
 &= u_{\langle b,d|\emptyset \rangle} - u_{\langle c,d|ab \rangle} + u_{\langle a,b|cd \rangle} \\
 &= (\delta_\emptyset - \delta_{\{b\}} - \delta_{\{d\}} + \delta_{\{b,d\}} + \delta_{\{c,d\}} - \delta_{\{a,c,d\}} - \delta_{\{b,c,d\}} + \delta_{\{a,b,c,d\}}) \\
 &\quad - (\delta_{\{a,b\}} - \delta_{\{a,b,c\}} - \delta_{\{a,b,d\}} + \delta_{\{a,b,c,d\}})
 \end{aligned}$$

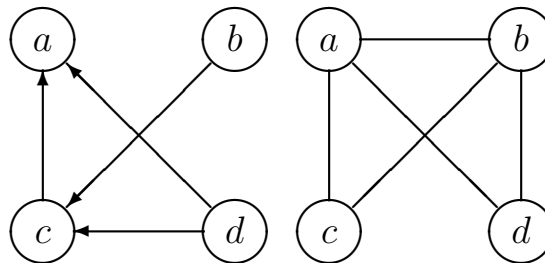

### 1.12 Squared Euclidean length 12

#### 1.12.6 Number of nonzero values 6

##### 1.12.6.1 Differential imset (151)

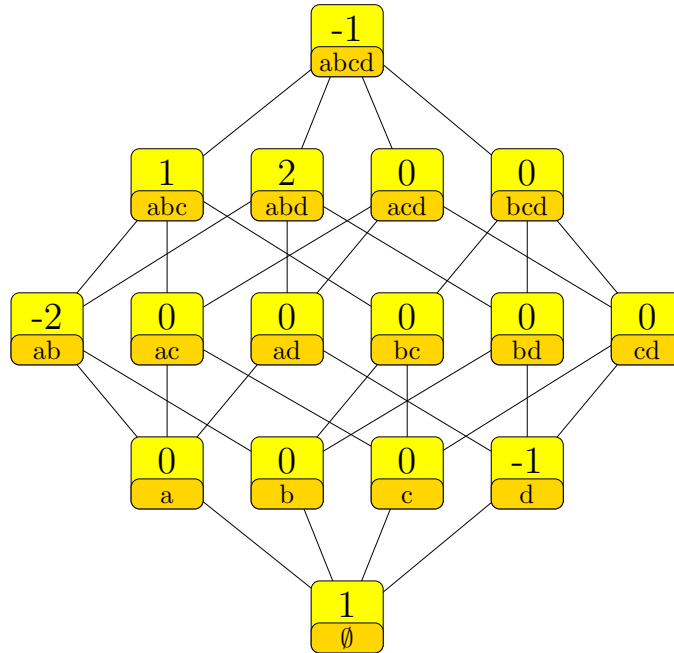

$$\begin{aligned}
 & \delta_\emptyset - \delta_{\{d\}} - 2\delta_{\{a,b\}} + \delta_{\{a,b,c\}} + 2\delta_{\{a,b,d\}} - \delta_{\{a,b,c,d\}} \\
 &= u_{\langle a,d|\emptyset \rangle} - u_{\langle c,d|ab \rangle} + u_{\langle b,d|a \rangle} \\
 &= (\delta_\emptyset - \delta_{\{d\}} - \delta_{\{a,b\}} + \delta_{\{a,b,d\}}) \\
 &\quad - (\delta_{\{a,b\}} - \delta_{\{a,b,c\}} - \delta_{\{a,b,d\}} + \delta_{\{a,b,c,d\}})
 \end{aligned}$$

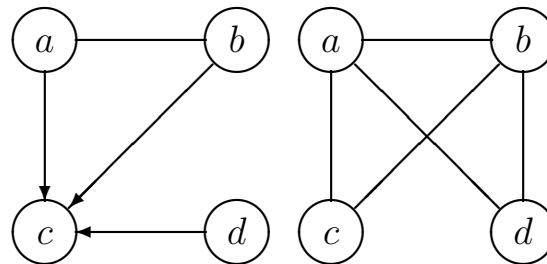



1.12.6.2 Differential imset (152)

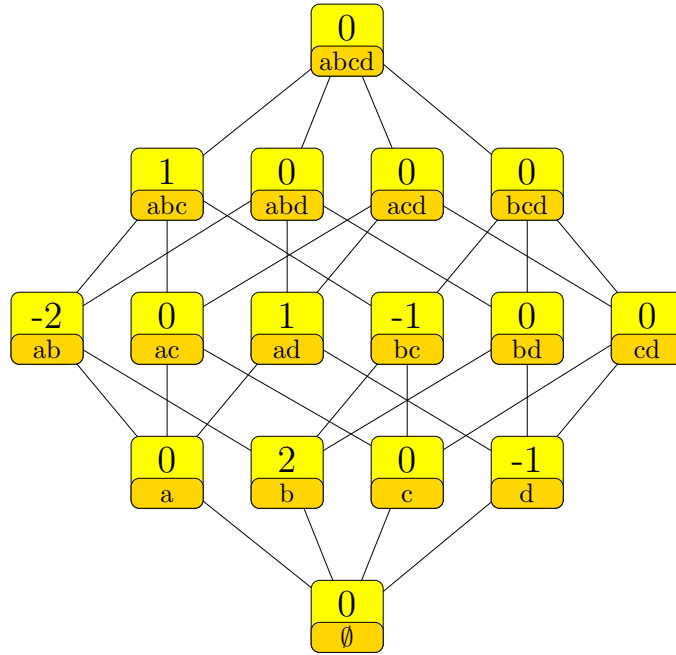

$$\begin{aligned}
 &+2\delta_{\{b\}} - \delta_{\{d\}} - 2\delta_{\{a,b\}} + \delta_{\{a,d\}} - \delta_{\{b,c\}} + \delta_{\{a,b,c\}} \\
 &= -u_{\langle a,b|\emptyset \rangle} + u_{\langle a,d|\emptyset \rangle} + u_{\langle a,c|b \rangle} \\
 &= (\delta_{\emptyset} + \delta_{\{b\}} - \delta_{\{d\}} - \delta_{\{a,b\}} - \delta_{\{b,c\}} + \delta_{\{a,b,c,d\}}) \\
 &\quad - (\delta_{\emptyset} - \delta_{\{b\}} + \delta_{\{a,b\}} - \delta_{\{a,d\}} - \delta_{\{a,b,c\}} + \delta_{\{a,b,c,d\}})
 \end{aligned}$$

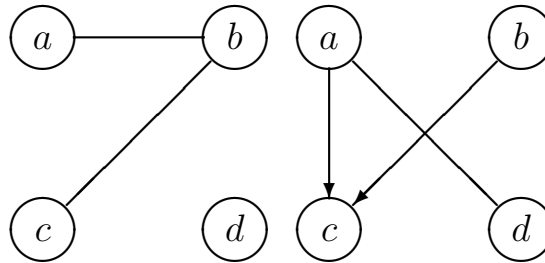

1.12.6.3 Differential imset (153)

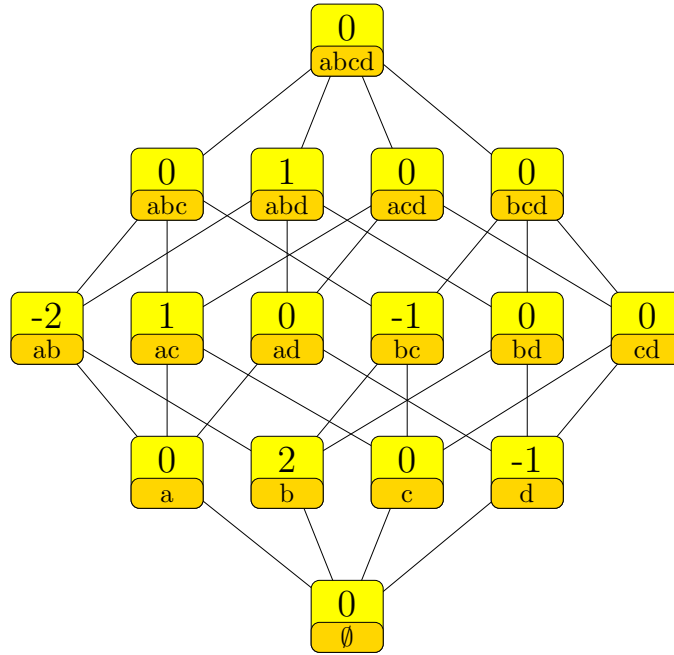

$$\begin{aligned}
 &+2\delta_{\{b\}} - \delta_{\{d\}} - 2\delta_{\{a,b\}} + \delta_{\{a,c\}} - \delta_{\{b,c\}} + \delta_{\{a,b,d\}} \\
 &= -u_{\langle a,b|\emptyset \rangle} + u_{\langle a,d|\emptyset \rangle} - u_{\langle b,c|a \rangle} + u_{\langle b,d|a \rangle} + u_{\langle a,c|b \rangle} \\
 &= (\delta_{\emptyset} + \delta_{\{b\}} - \delta_{\{d\}} - \delta_{\{a,b\}} - \delta_{\{b,c\}} + \delta_{\{a,b,c,d\}}) \\
 &\quad - (\delta_{\emptyset} - \delta_{\{b\}} + \delta_{\{a,b\}} - \delta_{\{a,c\}} - \delta_{\{a,b,d\}} + \delta_{\{a,b,c,d\}})
 \end{aligned}$$

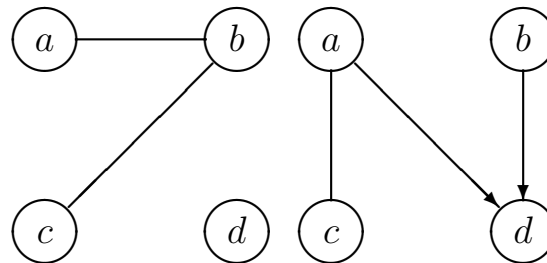

1.12.6.4 Differential imset (154)

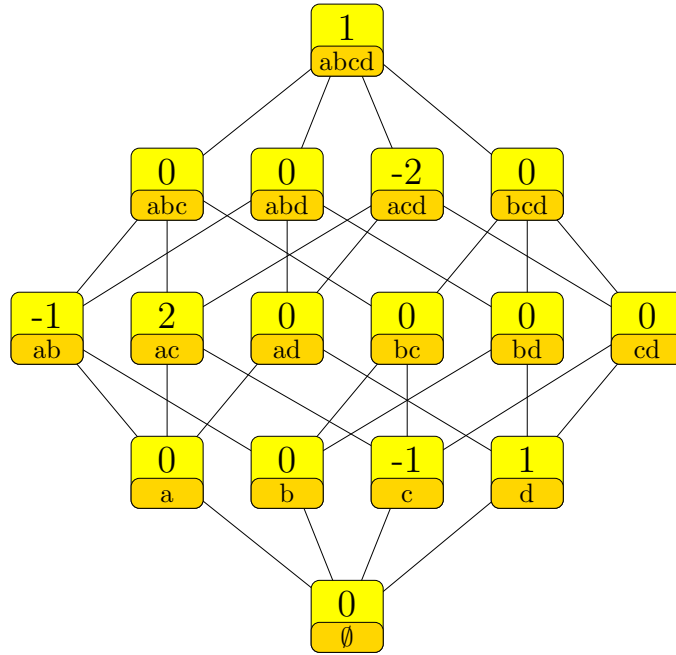

$$\begin{aligned}
 & -\delta_{\{c\}} + \delta_{\{d\}} - \delta_{\{a,b\}} + 2\delta_{\{a,c\}} - 2\delta_{\{a,c,d\}} + \delta_{\{a,b,c,d\}} \\
 &= u_{\langle a,c|\emptyset \rangle} - u_{\langle a,d|\emptyset \rangle} + u_{\langle b,d|ac \rangle} + u_{\langle b,c|a \rangle} - u_{\langle c,d|a \rangle} \\
 &= (\delta_{\emptyset} - \delta_{\{c\}} - \delta_{\{a,b\}} + \delta_{\{a,c\}} - \delta_{\{a,c,d\}} + \delta_{\{a,b,c,d\}}) \\
 &\quad - (\delta_{\emptyset} - \delta_{\{d\}} - \delta_{\{a,c\}} + \delta_{\{a,c,d\}})
 \end{aligned}$$

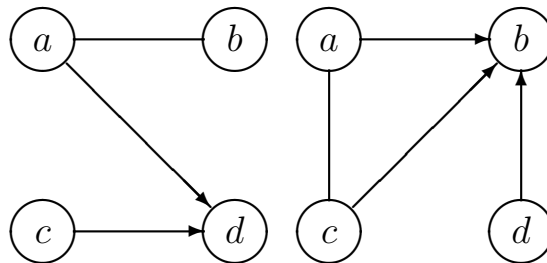

1.12.6.5 Differential imset (155)

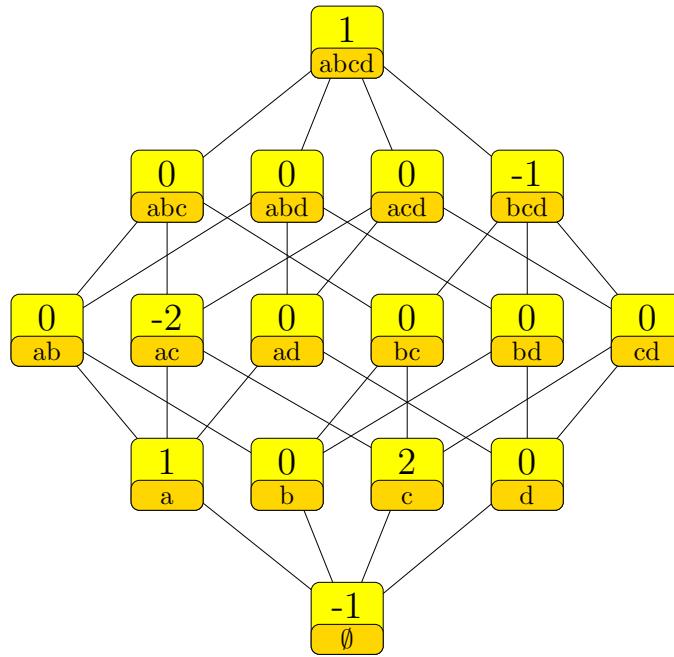

$$\begin{aligned}
 & -\delta_{\emptyset} + \delta_{\{a\}} + 2\delta_{\{c\}} - 2\delta_{\{a,c\}} - \delta_{\{b,c,d\}} + \delta_{\{a,b,c,d\}} \\
 &= -u_{\langle a,c|\emptyset \rangle} + u_{\langle a,d|bc \rangle} + u_{\langle a,b|c \rangle} \\
 &= (\delta_{\{c\}} - \delta_{\{a,c\}} - \delta_{\{b,c,d\}} + \delta_{\{a,b,c,d\}}) \\
 &\quad - (\delta_{\emptyset} - \delta_{\{a\}} - \delta_{\{c\}} + \delta_{\{a,c\}})
 \end{aligned}$$

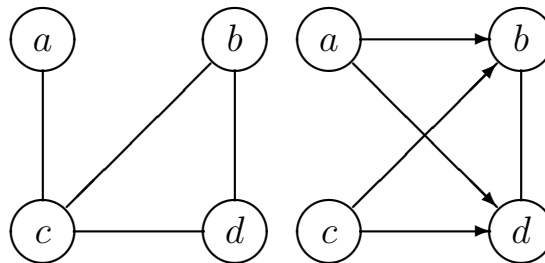

1.12.6.6 Differential imset (156)

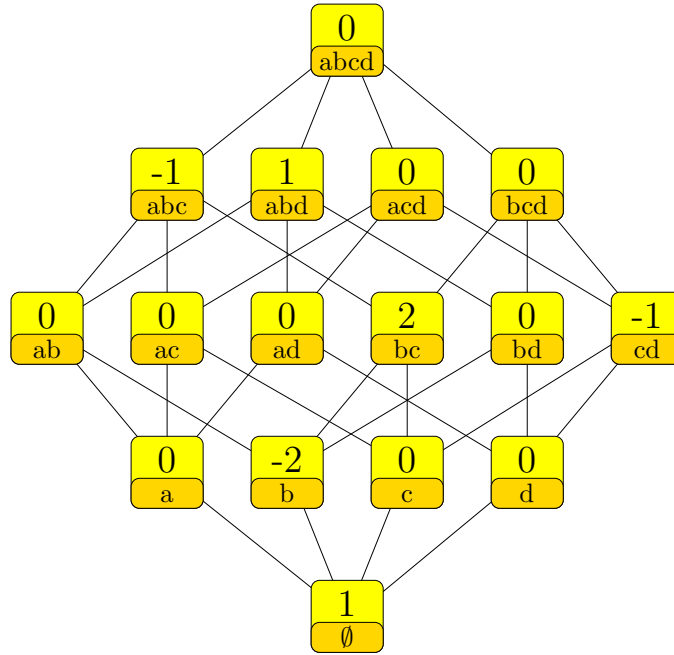

$$\begin{aligned}
 \delta_\emptyset - 2\delta_{\{b\}} + 2\delta_{\{b,c\}} - \delta_{\{c,d\}} - \delta_{\{a,b,c\}} + \delta_{\{a,b,d\}} \\
 &= u_{\langle b,c|\emptyset \rangle} - u_{\langle c,d|ab \rangle} + u_{\langle b,d|ac \rangle} - u_{\langle a,c|b \rangle} + u_{\langle a,d|c \rangle} \\
 &= (\delta_\emptyset - \delta_{\{b\}} + \delta_{\{b,c\}} - \delta_{\{c,d\}} - \delta_{\{a,b,c\}} + \delta_{\{a,b,c,d\}}) \\
 &\quad - (\delta_{\{b\}} - \delta_{\{b,c\}} - \delta_{\{a,b,d\}} + \delta_{\{a,b,c,d\}})
 \end{aligned}$$

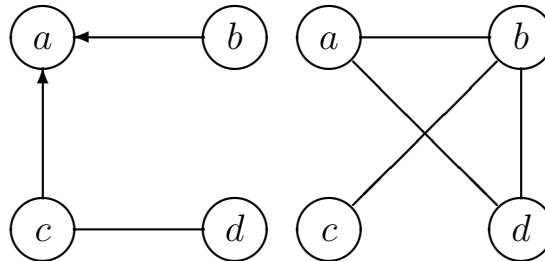

1.12.9 Number of nonzero values 9

1.12.9.1 Differential imset (157)

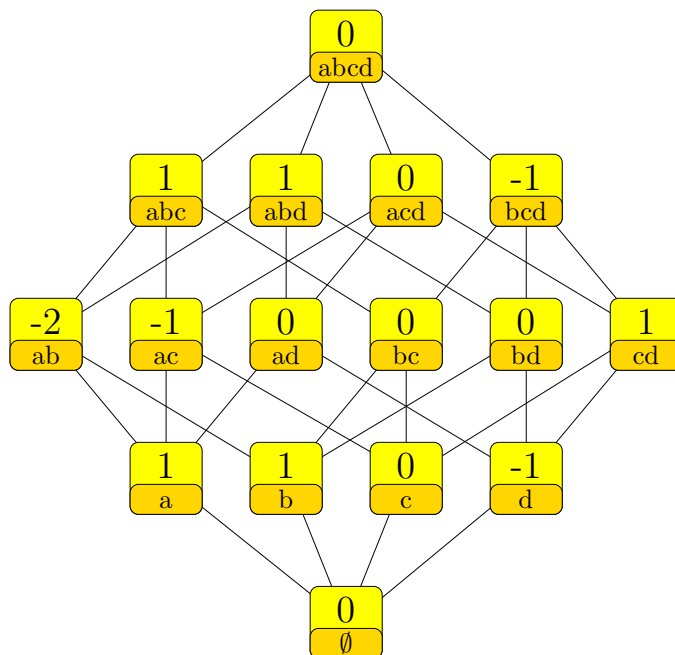

$$\begin{aligned}
 & \delta_{\{a\}} + \delta_{\{b\}} - \delta_{\{d\}} - 2\delta_{\{a,b\}} - \delta_{\{a,c\}} + \delta_{\{c,d\}} + \delta_{\{a,b,c\}} + \delta_{\{a,b,d\}} - \delta_{\{b,c,d\}} \\
 &= u_{\langle b,c|a \rangle} + u_{\langle a,d|b \rangle} - u_{\langle b,c|d \rangle} \\
 &= (\delta_{\emptyset} + \delta_{\{b\}} - \delta_{\{c\}} - \delta_{\{d\}} - \delta_{\{a,b\}} + \delta_{\{c,d\}} - \delta_{\{b,c,d\}} + \delta_{\{a,b,c,d\}}) \\
 &\quad - (\delta_{\emptyset} - \delta_{\{a\}} - \delta_{\{c\}} + \delta_{\{a,b\}} + \delta_{\{a,c\}} - \delta_{\{a,b,c\}} - \delta_{\{a,b,d\}} + \delta_{\{a,b,c,d\}})
 \end{aligned}$$

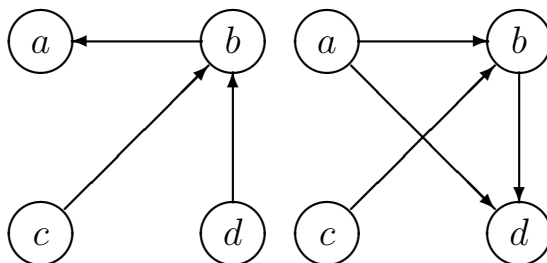

1.12.9.2 Differential imset (158)

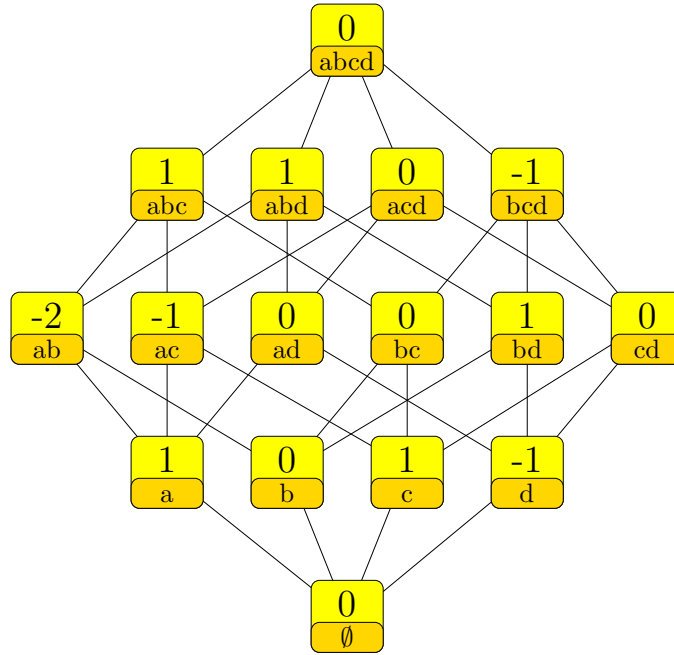

$$\begin{aligned}
 & \delta_{\{a\}} + \delta_{\{c\}} - \delta_{\{d\}} - 2\delta_{\{a,b\}} - \delta_{\{a,c\}} + \delta_{\{b,d\}} + \delta_{\{a,b,c\}} + \delta_{\{a,b,d\}} - \delta_{\{b,c,d\}} \\
 &= -u_{\langle a,c|\emptyset \rangle} + u_{\langle a,d|\emptyset \rangle} - u_{\langle c,d|ab \rangle} + u_{\langle a,c|bd \rangle} + u_{\langle b,d|a \rangle} \\
 &= (\delta_{\emptyset} - \delta_{\{d\}} - \delta_{\{a,b\}} + \delta_{\{b,d\}} - \delta_{\{b,c,d\}} + \delta_{\{a,b,c,d\}}) \\
 &\quad - (\delta_{\emptyset} - \delta_{\{a\}} - \delta_{\{c\}} + \delta_{\{a,b\}} + \delta_{\{a,c\}} - \delta_{\{a,b,c\}} - \delta_{\{a,b,d\}} + \delta_{\{a,b,c,d\}})
 \end{aligned}$$

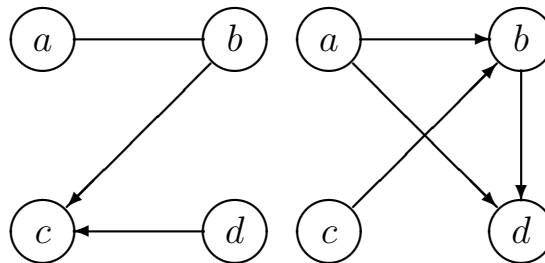

1.12.9.3 Differential imset (159)

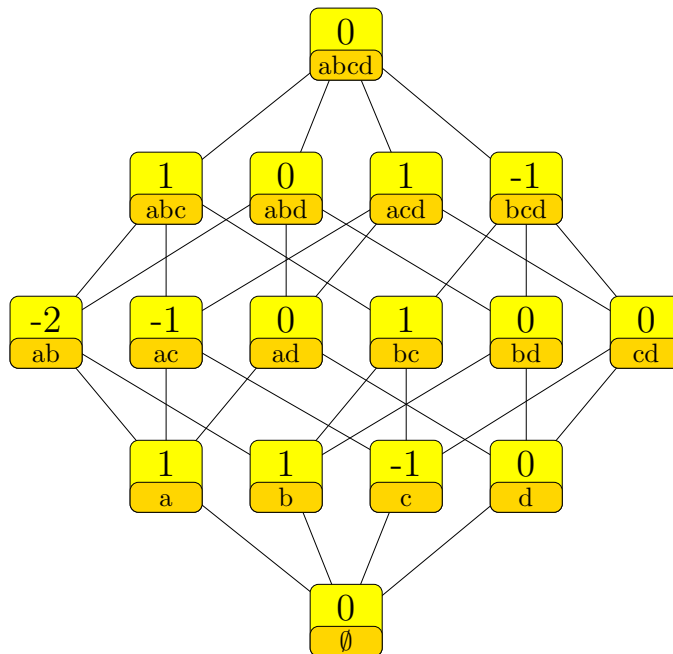

$$\begin{aligned}
 & \delta_{\{a\}} + \delta_{\{b\}} - \delta_{\{c\}} - 2\delta_{\{a,b\}} - \delta_{\{a,c\}} + \delta_{\{b,c\}} + \delta_{\{a,b,c\}} + \delta_{\{a,c,d\}} - \delta_{\{b,c,d\}} \\
 &= -u_{\langle a,b|\emptyset \rangle} + u_{\langle a,c|\emptyset \rangle} - u_{\langle b,d|ac \rangle} + u_{\langle a,d|bc \rangle} + u_{\langle b,c|a \rangle} \\
 &= (\delta_{\emptyset} - \delta_{\{c\}} - \delta_{\{a,b\}} + \delta_{\{b,c\}} - \delta_{\{b,c,d\}} + \delta_{\{a,b,c,d\}}) \\
 &\quad - (\delta_{\emptyset} - \delta_{\{a\}} - \delta_{\{b\}} + \delta_{\{a,b\}} + \delta_{\{a,c\}} - \delta_{\{a,b,c\}} - \delta_{\{a,c,d\}} + \delta_{\{a,b,c,d\}})
 \end{aligned}$$

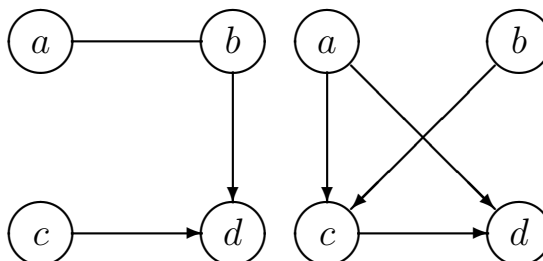



1.12.9.4 Differential imset (160)

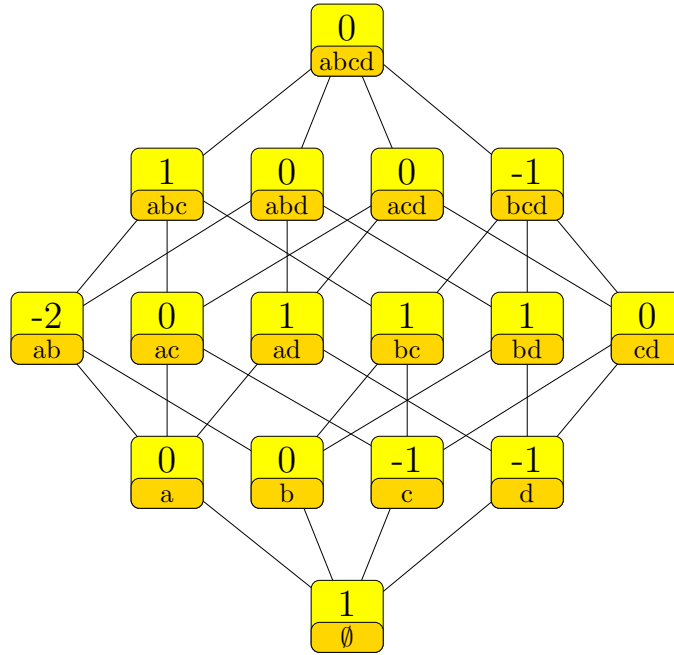

$$\begin{aligned}
 & \delta_{\emptyset} - \delta_{\{c\}} - \delta_{\{d\}} - 2\delta_{\{a,b\}} + \delta_{\{a,d\}} + \delta_{\{b,c\}} + \delta_{\{b,d\}} + \delta_{\{a,b,c\}} - \delta_{\{b,c,d\}} \\
 &= u_{\langle a,c|\emptyset \rangle} - u_{\langle c,d|ab \rangle} + u_{\langle a,d|bc \rangle} + u_{\langle b,c|a \rangle} - u_{\langle a,b|d \rangle} \\
 &= (\delta_{\emptyset} - \delta_{\{c\}} - \delta_{\{a,b\}} + \delta_{\{b,c\}} - \delta_{\{b,c,d\}} + \delta_{\{a,b,c,d\}}) \\
 &\quad - (\delta_{\{d\}} + \delta_{\{a,b\}} - \delta_{\{a,d\}} - \delta_{\{b,d\}} - \delta_{\{a,b,c\}} + \delta_{\{a,b,c,d\}})
 \end{aligned}$$

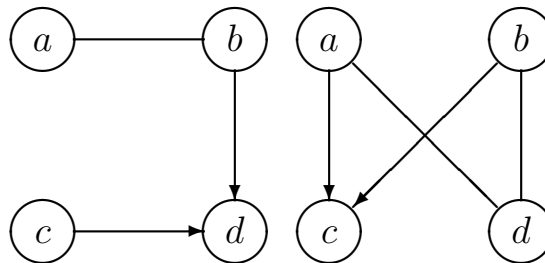

1.12.9.5 Differential imset (161)

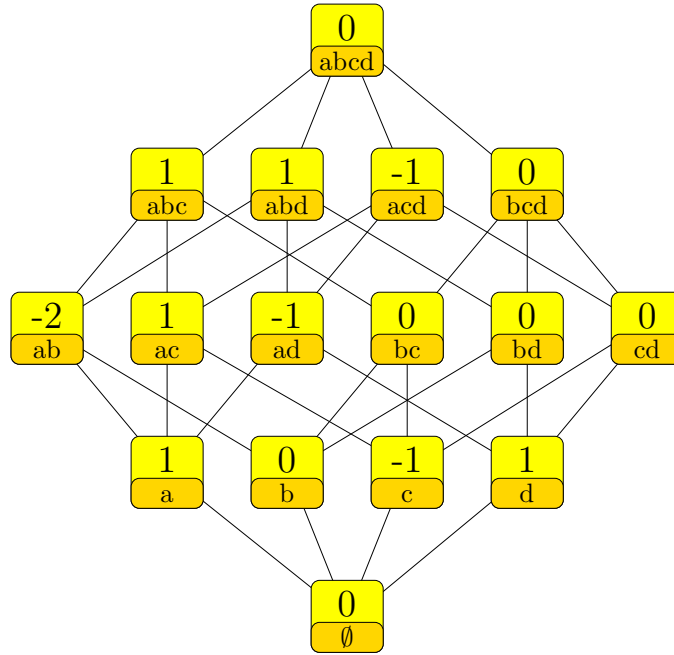

$$\begin{aligned}
 & \delta_{\{a\}} - \delta_{\{c\}} + \delta_{\{d\}} - 2\delta_{\{a,b\}} + \delta_{\{a,c\}} - \delta_{\{a,d\}} + \delta_{\{a,b,c\}} + \delta_{\{a,b,d\}} - \delta_{\{a,c,d\}} \\
 &= u_{\langle a,c|\emptyset} - u_{\langle a,d|\emptyset} - u_{\langle c,d|ab} + u_{\langle b,d|ac} + u_{\langle b,c|a} \\
 &= (\delta_{\emptyset} - \delta_{\{c\}} - \delta_{\{a,b\}} + \delta_{\{a,c\}} - \delta_{\{a,c,d\}} + \delta_{\{a,b,c,d\}}) \\
 &\quad - (\delta_{\emptyset} - \delta_{\{a\}} - \delta_{\{d\}} + \delta_{\{a,b\}} + \delta_{\{a,d\}} - \delta_{\{a,b,c\}} - \delta_{\{a,b,d\}} + \delta_{\{a,b,c,d\}})
 \end{aligned}$$

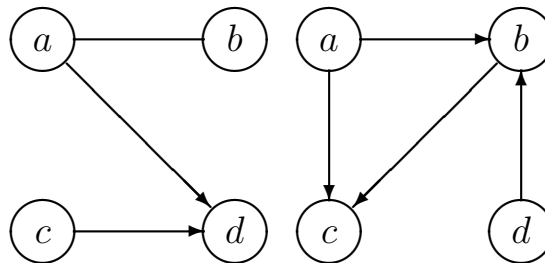

1.12.9.6 Differential imset (162)

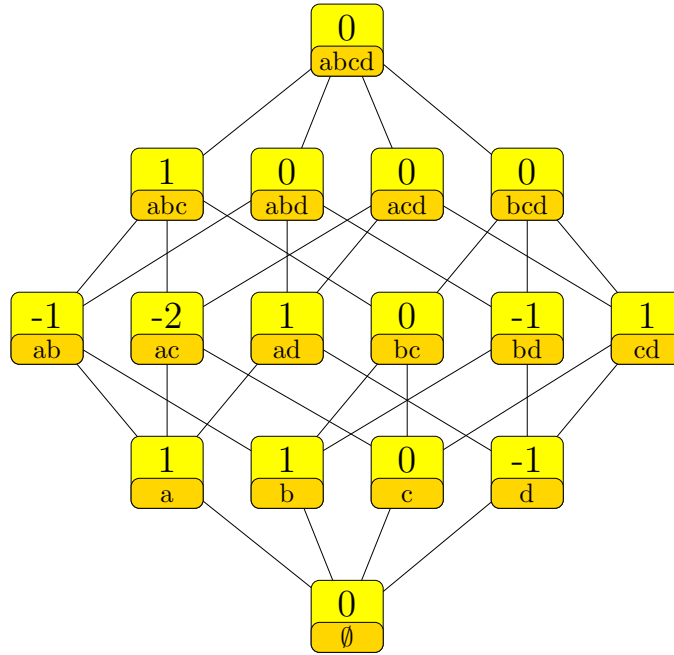

$$\begin{aligned}
 & \delta_{\{a\}} + \delta_{\{b\}} - \delta_{\{d\}} - \delta_{\{a,b\}} - 2\delta_{\{a,c\}} + \delta_{\{a,d\}} - \delta_{\{b,d\}} + \delta_{\{c,d\}} + \delta_{\{a,b,c\}} \\
 &= u_{\langle c,d|ab \rangle} - u_{\langle b,d|ac \rangle} + u_{\langle b,c|a \rangle} + u_{\langle a,d|b \rangle} - u_{\langle a,c|d \rangle} \\
 &= (\delta_{\{a\}} + \delta_{\{b\}} - \delta_{\{a,b\}} - \delta_{\{a,c\}} - \delta_{\{b,d\}} + \delta_{\{a,b,c,d\}}) \\
 &\quad - (\delta_{\{d\}} + \delta_{\{a,c\}} - \delta_{\{a,d\}} - \delta_{\{c,d\}} - \delta_{\{a,b,c\}} + \delta_{\{a,b,c,d\}})
 \end{aligned}$$

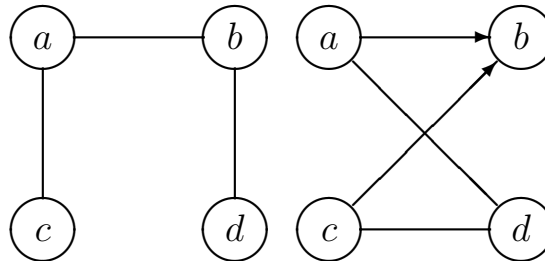

1.12.9.7 Differential imset (163)

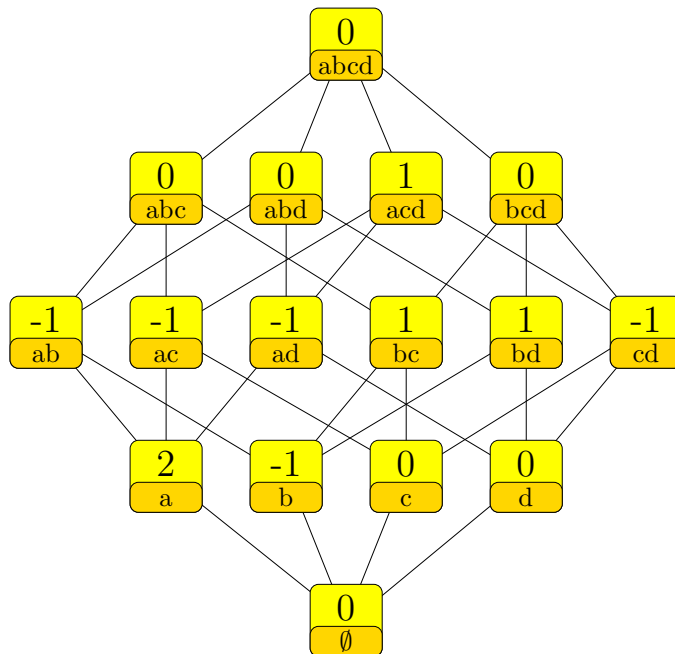

$$\begin{aligned}
 &+2\delta_{\{a\}} - \delta_{\{b\}} - \delta_{\{a,b\}} - \delta_{\{a,c\}} - \delta_{\{a,d\}} + \delta_{\{b,c\}} + \delta_{\{b,d\}} - \delta_{\{c,d\}} + \delta_{\{a,c,d\}} \\
 &= u_{\langle c,d|ab \rangle} - u_{\langle a,b|cd \rangle} + u_{\langle b,c|a \rangle} + u_{\langle b,d|a \rangle} - u_{\langle c,d|b \rangle} \\
 &= (+2\delta_{\{a\}} - \delta_{\{a,b\}} - \delta_{\{a,c\}} - \delta_{\{a,d\}} + \delta_{\{a,b,c,d\}}) \\
 &\quad - (\delta_{\{b\}} - \delta_{\{b,c\}} - \delta_{\{b,d\}} + \delta_{\{c,d\}} - \delta_{\{a,c,d\}} + \delta_{\{a,b,c,d\}})
 \end{aligned}$$

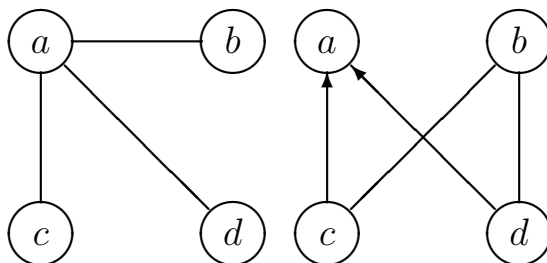

1.12.9.8 Differential imset (164)

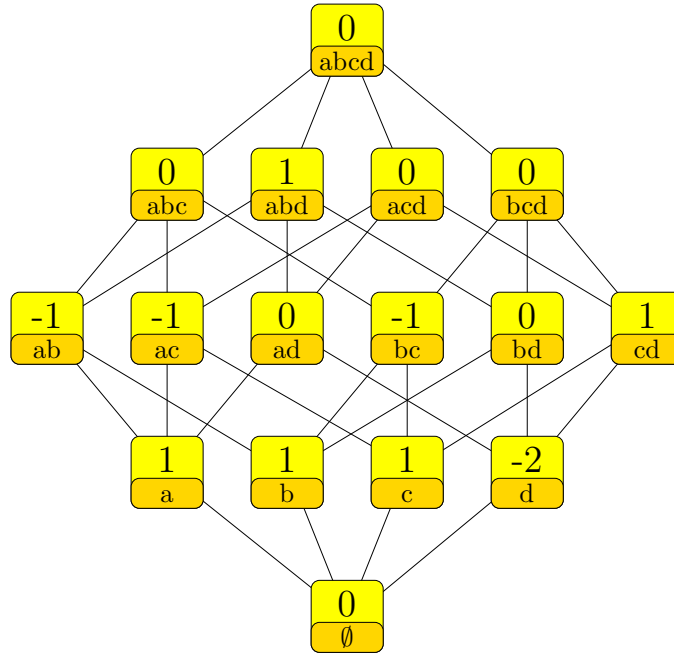

$$\begin{aligned}
 & \delta_{\{a\}} + \delta_{\{b\}} + \delta_{\{c\}} - 2\delta_{\{d\}} - \delta_{\{a,b\}} - \delta_{\{a,c\}} - \delta_{\{b,c\}} + \delta_{\{c,d\}} + \delta_{\{a,b,d\}} \\
 &= -u_{\langle a,c|\emptyset \rangle} + u_{\langle a,d|\emptyset \rangle} - u_{\langle b,c|\emptyset \rangle} + u_{\langle c,d|\emptyset \rangle} + u_{\langle b,d|a \rangle} \\
 &= (\delta_{\emptyset} + \delta_{\{c\}} - \delta_{\{d\}} - \delta_{\{a,c\}} - \delta_{\{b,c\}} + \delta_{\{a,b,c,d\}}) \\
 &\quad - (\delta_{\emptyset} - \delta_{\{a\}} - \delta_{\{b\}} + \delta_{\{d\}} + \delta_{\{a,b\}} - \delta_{\{c,d\}} - \delta_{\{a,b,d\}} + \delta_{\{a,b,c,d\}})
 \end{aligned}$$

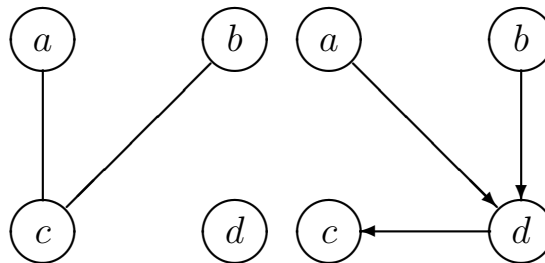

1.12.9.9 Differential imset (165)

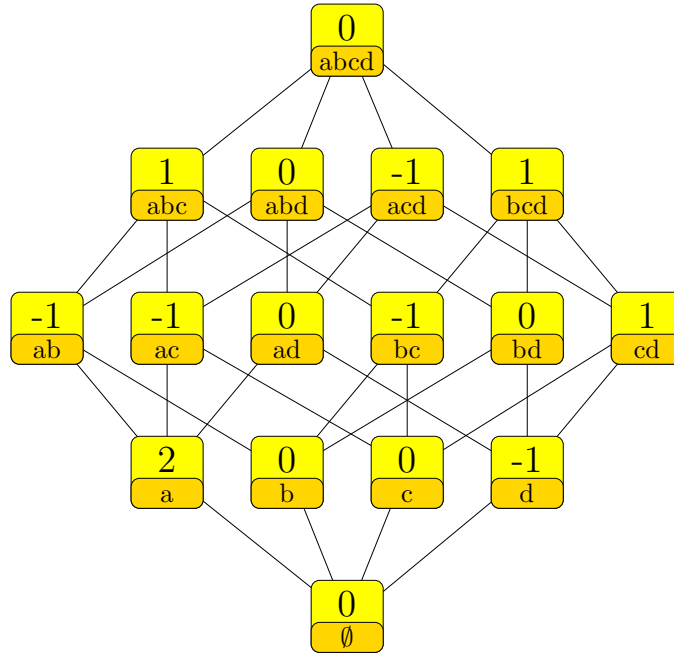

$$\begin{aligned}
 &+2\delta_{\{a\}} - \delta_{\{d\}} - \delta_{\{a,b\}} - \delta_{\{a,c\}} - \delta_{\{b,c\}} + \delta_{\{c,d\}} + \delta_{\{a,b,c\}} - \delta_{\{a,c,d\}} + \delta_{\{b,c,d\}} \\
 &= -u_{\langle a,c|\emptyset\rangle} + u_{\langle c,d|\emptyset\rangle} + u_{\langle b,d|ac\rangle} - u_{\langle a,d|bc\rangle} + u_{\langle b,c|a\rangle} \\
 &= (\delta_{\emptyset} + \delta_{\{a\}} - \delta_{\{c\}} - \delta_{\{d\}} - \delta_{\{a,b\}} + \delta_{\{c,d\}} - \delta_{\{a,c,d\}} + \delta_{\{a,b,c,d\}}) \\
 &\quad - (\delta_{\emptyset} - \delta_{\{a\}} - \delta_{\{c\}} + \delta_{\{a,c\}} + \delta_{\{b,c\}} - \delta_{\{a,b,c\}} - \delta_{\{b,c,d\}} + \delta_{\{a,b,c,d\}})
 \end{aligned}$$

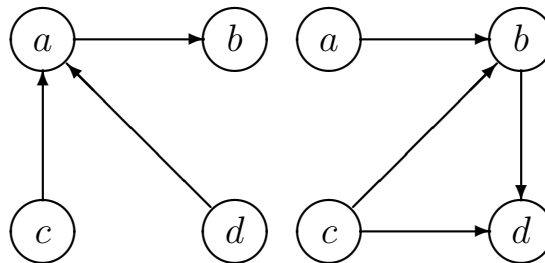

1.12.9.10 Differential imset (166)

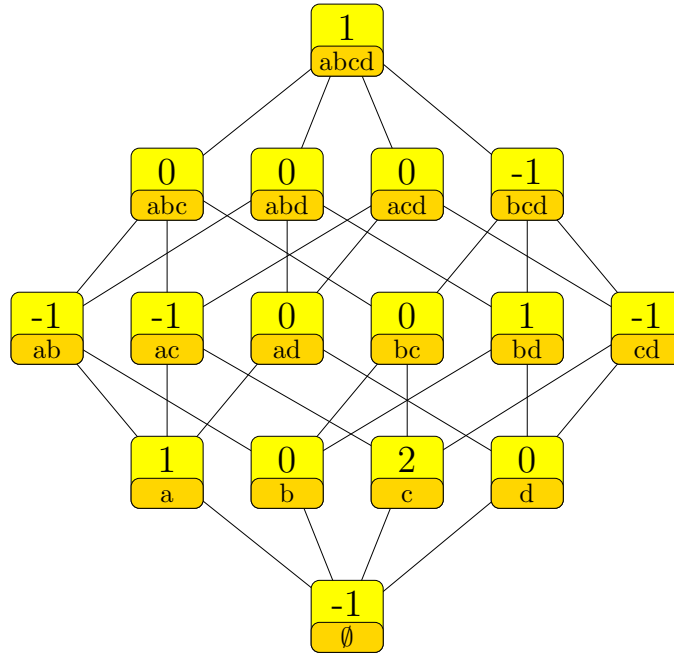

$$\begin{aligned}
 & -\delta_\emptyset + \delta_{\{a\}} + 2\delta_{\{c\}} - \delta_{\{a,b\}} - \delta_{\{a,c\}} + \delta_{\{b,d\}} - \delta_{\{c,d\}} - \delta_{\{b,c,d\}} + \delta_{\{a,b,c,d\}} \\
 &= -u_{\langle b,c|\emptyset \rangle} + u_{\langle b,d|ac \rangle} + u_{\langle b,c|a \rangle} + u_{\langle a,d|c \rangle} - u_{\langle c,d|b \rangle} \\
 &= (\delta_{\{a\}} + \delta_{\{c\}} - \delta_{\{a,b\}} - \delta_{\{a,c\}} - \delta_{\{c,d\}} + \delta_{\{a,b,c,d\}}) \\
 &\quad - (\delta_\emptyset - \delta_{\{c\}} - \delta_{\{b,d\}} + \delta_{\{b,c,d\}})
 \end{aligned}$$

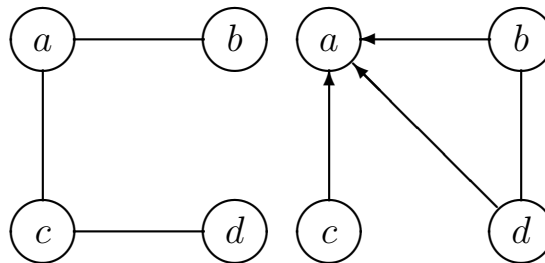

1.12.9.11 Differential imset (167)

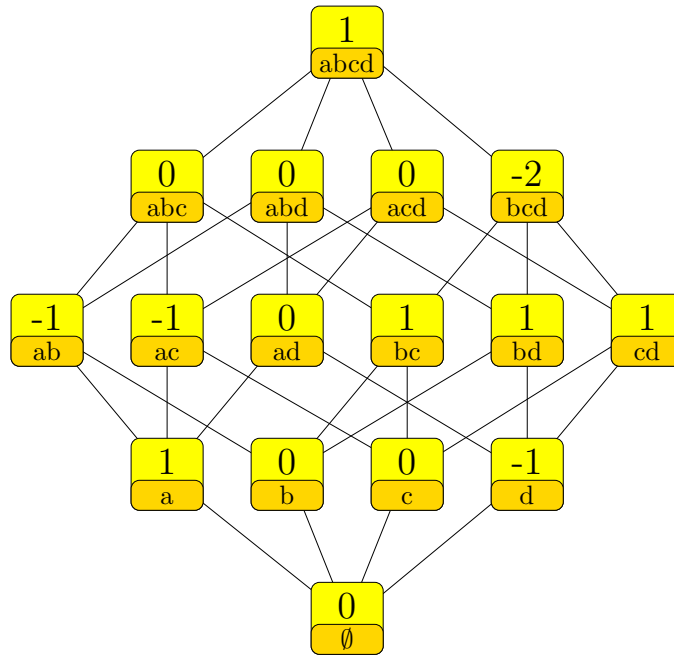

$$\begin{aligned}
 & \delta_{\{a\}} - \delta_{\{d\}} - \delta_{\{a,b\}} - \delta_{\{a,c\}} + \delta_{\{b,c\}} + \delta_{\{b,d\}} + \delta_{\{c,d\}} - 2\delta_{\{b,c,d\}} + \delta_{\{a,b,c,d\}} \\
 &= u_{\langle a,d|bc \rangle} + u_{\langle b,c|a \rangle} - u_{\langle b,c|d \rangle} \\
 &= (\delta_{\{a\}} - \delta_{\{a,b\}} - \delta_{\{a,c\}} + \delta_{\{b,c\}} - \delta_{\{b,c,d\}} + \delta_{\{a,b,c,d\}}) \\
 &\quad - (\delta_{\{d\}} - \delta_{\{b,d\}} - \delta_{\{c,d\}} + \delta_{\{b,c,d\}})
 \end{aligned}$$

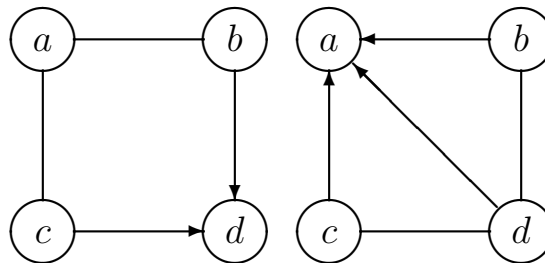



1.12.9.12 Differential imset (168)

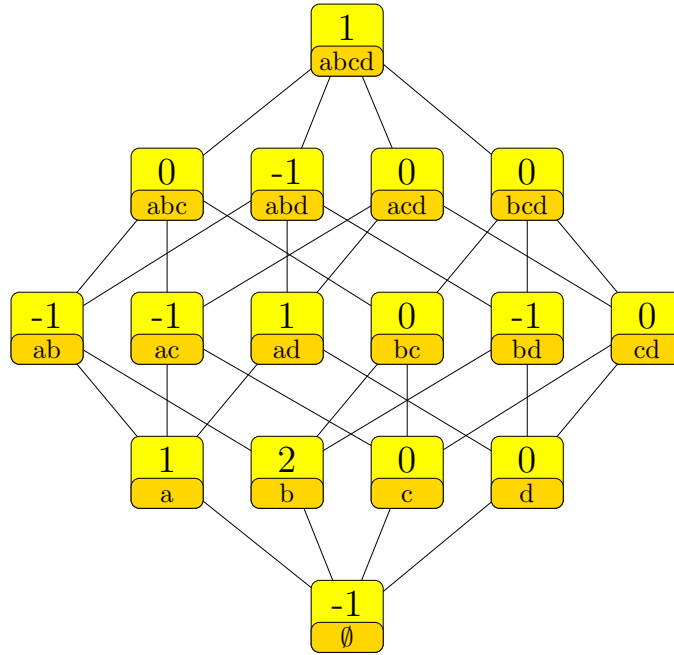

$$\begin{aligned}
 & -\delta_\emptyset + \delta_{\{a\}} + 2\delta_{\{b\}} - \delta_{\{a,b\}} - \delta_{\{a,c\}} + \delta_{\{a,d\}} - \delta_{\{b,d\}} - \delta_{\{a,b,d\}} + \delta_{\{a,b,c,d\}} \\
 &= -u_{\langle a,b|\emptyset \rangle} + u_{\langle c,d|ab \rangle} + u_{\langle b,c|a \rangle} - u_{\langle b,d|a \rangle} + u_{\langle a,d|b \rangle} \\
 &= (\delta_{\{a\}} + \delta_{\{b\}} - \delta_{\{a,b\}} - \delta_{\{a,c\}} - \delta_{\{b,d\}} + \delta_{\{a,b,c,d\}}) \\
 &\quad - (\delta_\emptyset - \delta_{\{b\}} - \delta_{\{a,d\}} + \delta_{\{a,b,d\}})
 \end{aligned}$$

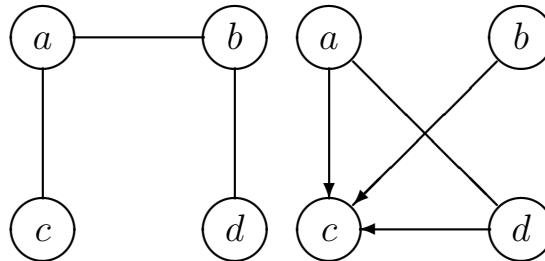

1.12.9.13 Differential imset (169)

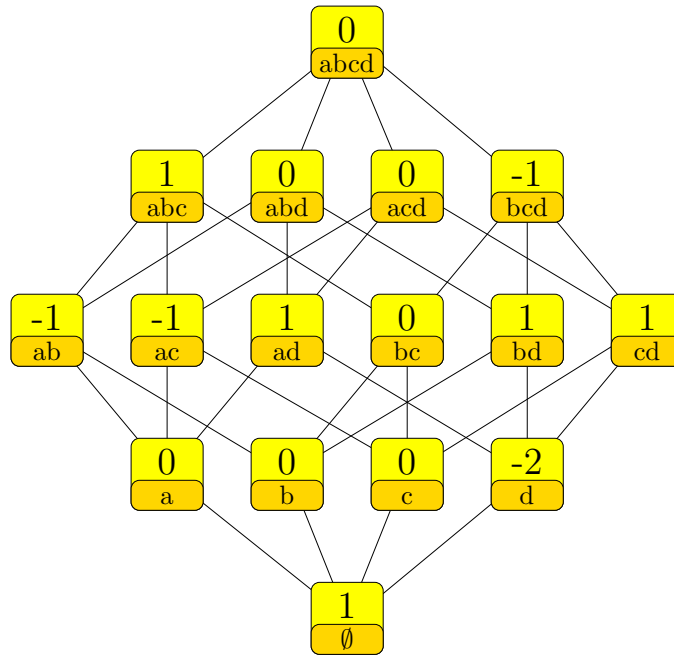

$$\begin{aligned}
 & \delta_{\emptyset} - 2\delta_{\{d\}} - \delta_{\{a,b\}} - \delta_{\{a,c\}} + \delta_{\{a,d\}} + \delta_{\{b,d\}} + \delta_{\{c,d\}} + \delta_{\{a,b,c\}} - \delta_{\{b,c,d\}} \\
 &= u_{\langle a,d|\emptyset \rangle} + u_{\langle b,c|a \rangle} - u_{\langle b,c|d \rangle} \\
 &= (\delta_{\emptyset} - \delta_{\{d\}} - \delta_{\{a,b\}} + \delta_{\{b,d\}} - \delta_{\{b,c,d\}} + \delta_{\{a,b,c,d\}}) \\
 &\quad - (\delta_{\{d\}} + \delta_{\{a,c\}} - \delta_{\{a,d\}} - \delta_{\{c,d\}} - \delta_{\{a,b,c\}} + \delta_{\{a,b,c,d\}})
 \end{aligned}$$

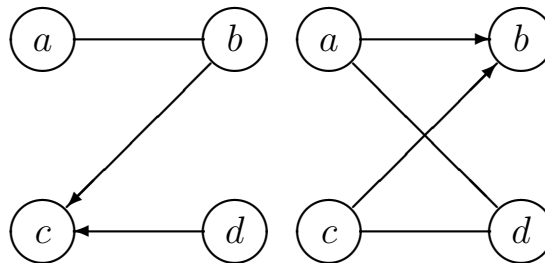

1.12.9.14 Differential imset (170)

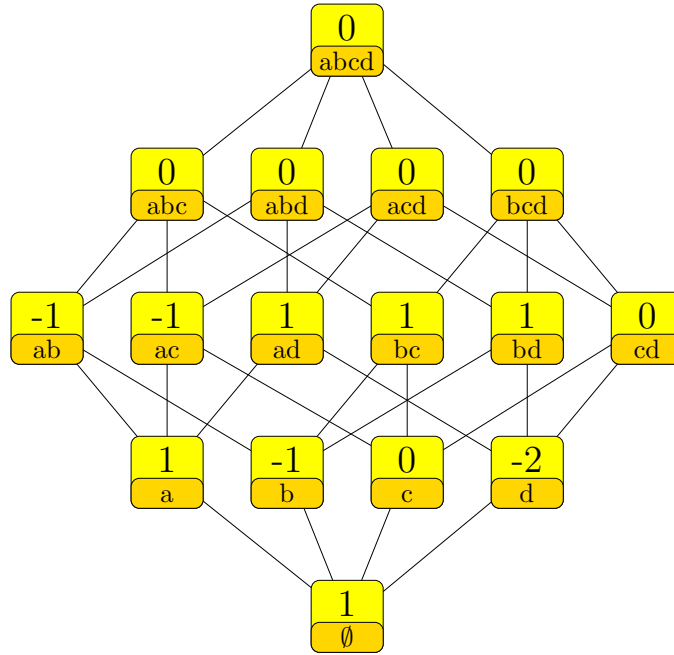

$$\begin{aligned}
 & \delta_{\emptyset} + \delta_{\{a\}} - \delta_{\{b\}} - 2\delta_{\{d\}} - \delta_{\{a,b\}} - \delta_{\{a,c\}} + \delta_{\{a,d\}} + \delta_{\{b,c\}} + \delta_{\{b,d\}} \\
 &= u_{\langle a,d|\emptyset \rangle} + u_{\langle b,c|a \rangle} + u_{\langle b,d|a \rangle} - u_{\langle a,c|b \rangle} - u_{\langle a,b|d \rangle} \\
 &= (\delta_{\emptyset} + \delta_{\{a\}} - \delta_{\{d\}} - \delta_{\{a,b\}} - \delta_{\{a,c\}} + \delta_{\{a,b,c,d\}}) \\
 &\quad - (\delta_{\{b\}} + \delta_{\{d\}} - \delta_{\{a,d\}} - \delta_{\{b,c\}} - \delta_{\{b,d\}} + \delta_{\{a,b,c,d\}})
 \end{aligned}$$

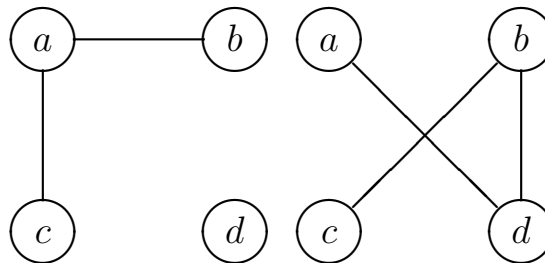

1.12.9.15 Differential imset (171)

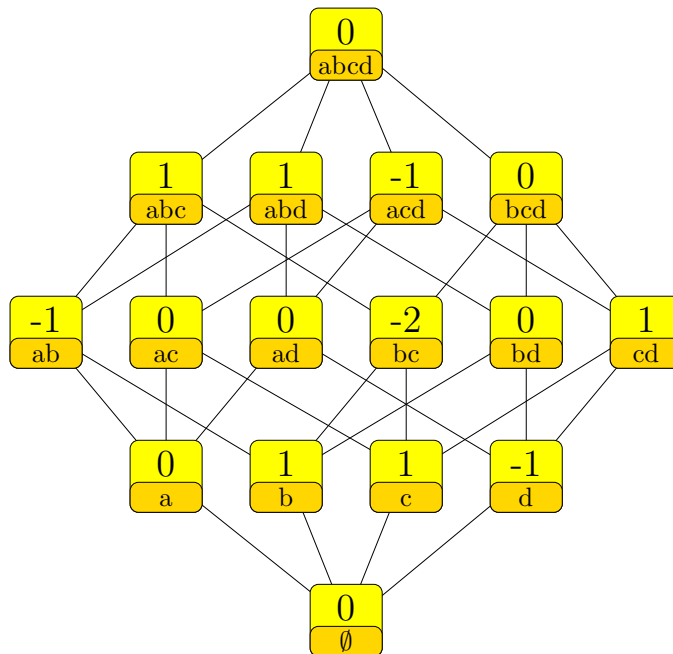

$$\begin{aligned}
 & \delta_{\{b\}} + \delta_{\{c\}} - \delta_{\{d\}} - \delta_{\{a,b\}} - 2\delta_{\{b,c\}} + \delta_{\{c,d\}} + \delta_{\{a,b,c\}} + \delta_{\{a,b,d\}} - \delta_{\{a,c,d\}} \\
 &= -u_{\langle b,c|\emptyset\rangle} + u_{\langle b,d|\emptyset\rangle} - u_{\langle c,d|ab\rangle} + u_{\langle a,b|cd\rangle} + u_{\langle c,d|b\rangle} \\
 &= (\delta_{\emptyset} - \delta_{\{d\}} - \delta_{\{b,c\}} + \delta_{\{c,d\}} - \delta_{\{a,c,d\}} + \delta_{\{a,b,c,d\}}) \\
 &\quad - (\delta_{\emptyset} - \delta_{\{b\}} - \delta_{\{c\}} + \delta_{\{a,b\}} + \delta_{\{b,c\}} - \delta_{\{a,b,c\}} - \delta_{\{a,b,d\}} + \delta_{\{a,b,c,d\}})
 \end{aligned}$$

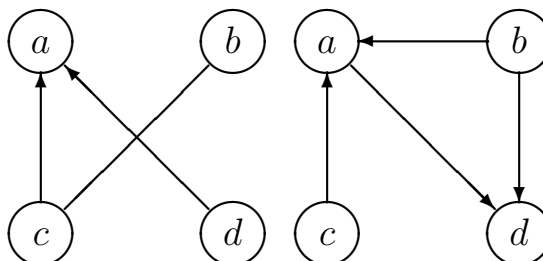

1.12.9.16 Differential imset (172)

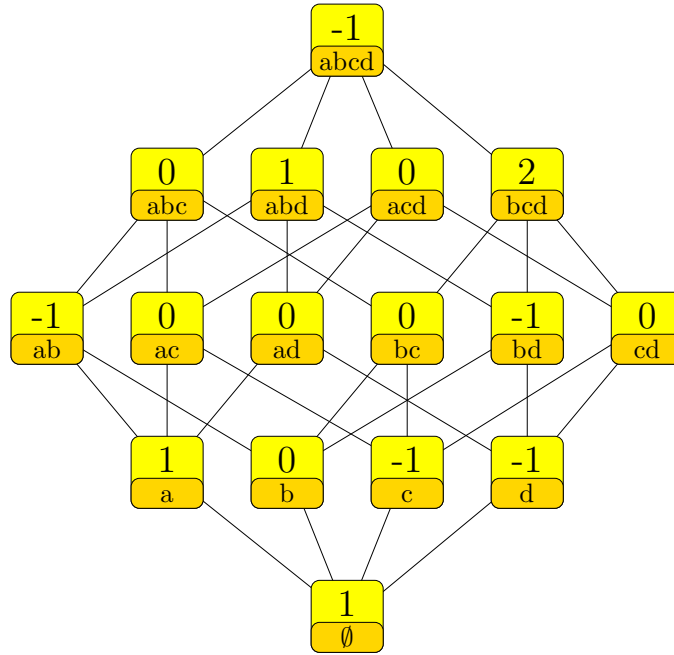

$$\begin{aligned}
 & \delta_\emptyset + \delta_{\{a\}} - \delta_{\{c\}} - \delta_{\{d\}} - \delta_{\{a,b\}} - \delta_{\{b,d\}} + \delta_{\{a,b,d\}} + 2\delta_{\{b,c,d\}} - \delta_{\{a,b,c,d\}} \\
 &= -u_{\langle a,b|\emptyset \rangle} + u_{\langle b,c|\emptyset \rangle} + u_{\langle b,d|\emptyset \rangle} - u_{\langle a,c|bd \rangle} + u_{\langle c,d|b \rangle} \\
 &= (+2\delta_\emptyset - \delta_{\{b\}} - \delta_{\{c\}} - \delta_{\{d\}} + \delta_{\{b,c,d\}}) \\
 &\quad - (\delta_\emptyset - \delta_{\{a\}} - \delta_{\{b\}} + \delta_{\{a,b\}} + \delta_{\{b,d\}} - \delta_{\{a,b,d\}} - \delta_{\{b,c,d\}} + \delta_{\{a,b,c,d\}})
 \end{aligned}$$

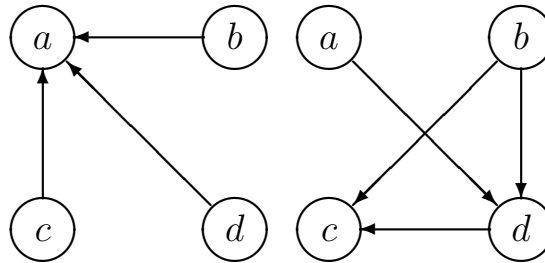

1.12.9.17 Differential imset (173)

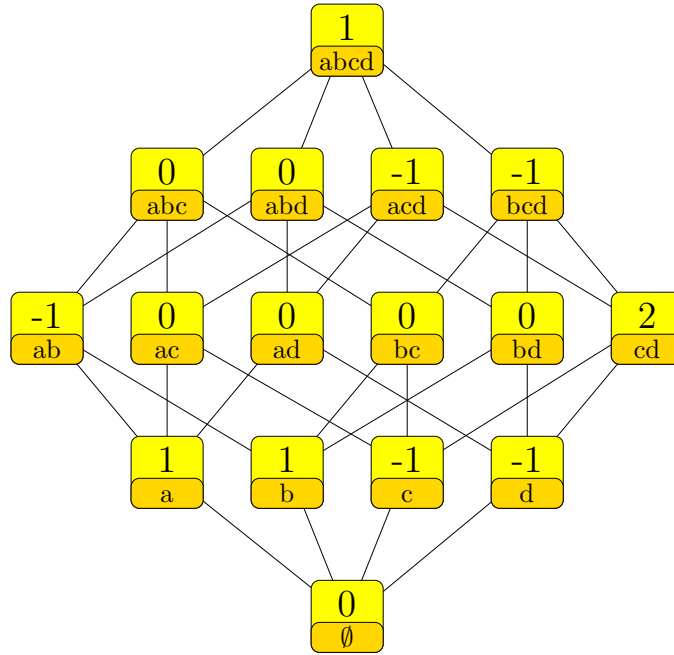

$$\begin{aligned}
 & \delta_{\{a\}} + \delta_{\{b\}} - \delta_{\{c\}} - \delta_{\{d\}} - \delta_{\{a,b\}} + 2\delta_{\{c,d\}} - \delta_{\{a,c,d\}} - \delta_{\{b,c,d\}} + \delta_{\{a,b,c,d\}} \\
 &= -u_{\langle a,b|\emptyset \rangle} + u_{\langle c,d|\emptyset \rangle} + u_{\langle a,b|cd \rangle} \\
 &= (\delta_{\emptyset} + \delta_{\{b\}} - \delta_{\{c\}} - \delta_{\{d\}} - \delta_{\{a,b\}} + \delta_{\{c,d\}} - \delta_{\{b,c,d\}} + \delta_{\{a,b,c,d\}}) \\
 &\quad - (\delta_{\emptyset} - \delta_{\{a\}} - \delta_{\{c,d\}} + \delta_{\{a,c,d\}}) \\
 &= (\delta_{\emptyset} - \delta_{\{c\}} - \delta_{\{d\}} + 2\delta_{\{c,d\}} - \delta_{\{a,c,d\}} - \delta_{\{b,c,d\}} + \delta_{\{a,b,c,d\}}) \\
 &\quad - (\delta_{\emptyset} - \delta_{\{a\}} - \delta_{\{b\}} + \delta_{\{a,b\}})
 \end{aligned}$$

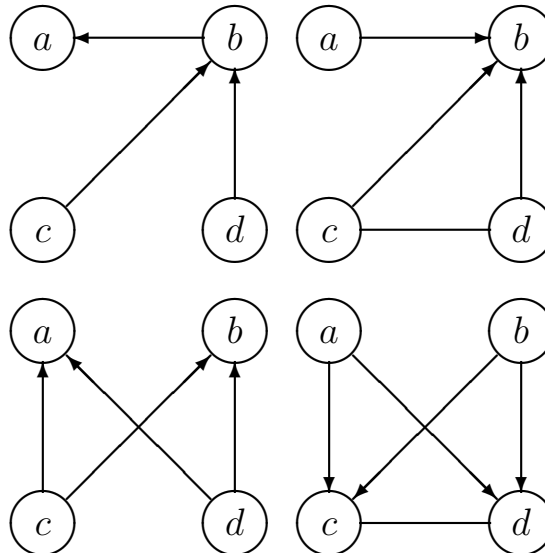

1.12.9.18 Differential imset (174)

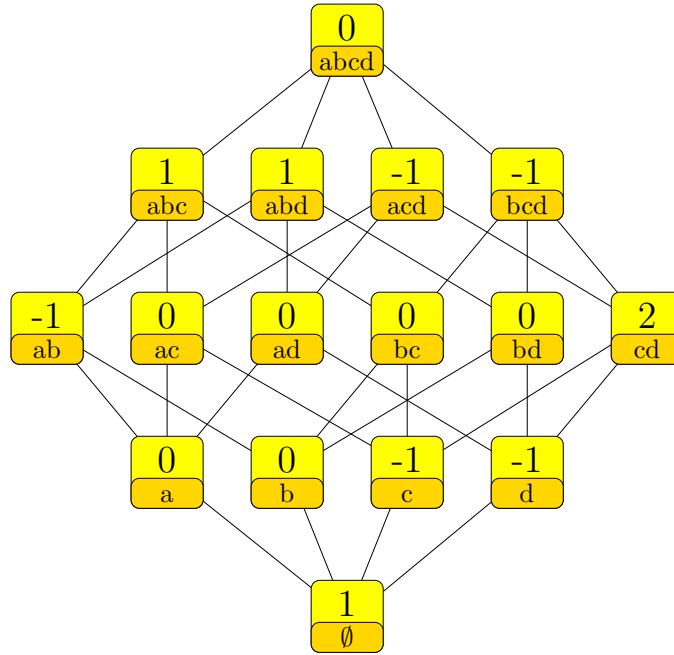

$$\begin{aligned}
 & \delta_{\emptyset} - \delta_{\{c\}} - \delta_{\{d\}} - \delta_{\{a,b\}} + 2\delta_{\{c,d\}} + \delta_{\{a,b,c\}} + \delta_{\{a,b,d\}} - \delta_{\{a,c,d\}} - \delta_{\{b,c,d\}} \\
 &= u_{\langle c,d|\emptyset \rangle} - u_{\langle c,d|ab \rangle} + u_{\langle a,b|cd \rangle} \\
 &= (\delta_{\emptyset} - \delta_{\{c\}} - \delta_{\{d\}} + 2\delta_{\{c,d\}} - \delta_{\{a,c,d\}} - \delta_{\{b,c,d\}} + \delta_{\{a,b,c,d\}}) \\
 &\quad - (\delta_{\{a,b\}} - \delta_{\{a,b,c\}} - \delta_{\{a,b,d\}} + \delta_{\{a,b,c,d\}})
 \end{aligned}$$

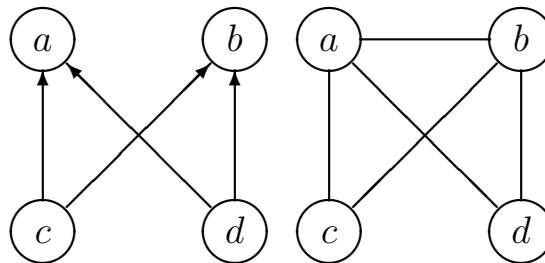

1.12.9.19 Differential imset (175)

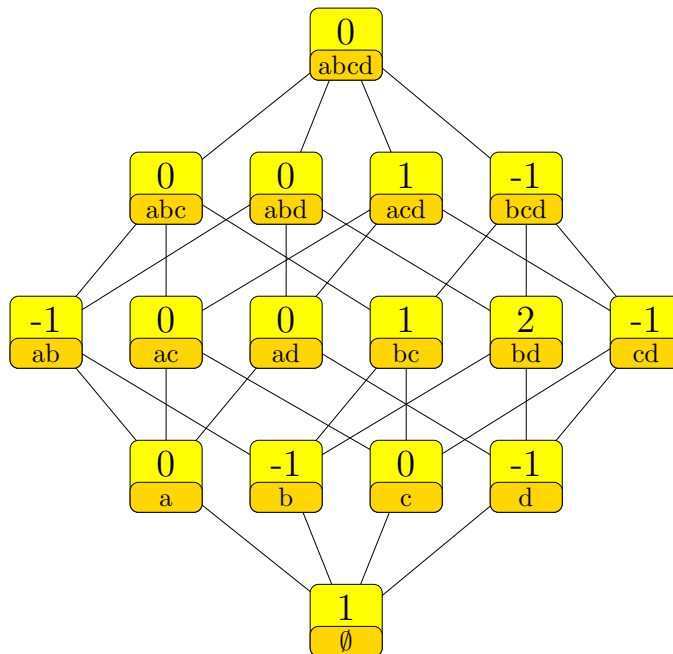

$$\begin{aligned}
 & \delta_\emptyset - \delta_{\{b\}} - \delta_{\{d\}} - \delta_{\{a,b\}} + \delta_{\{b,c\}} + 2\delta_{\{b,d\}} - \delta_{\{c,d\}} + \delta_{\{a,c,d\}} - \delta_{\{b,c,d\}} \\
 &= u_{\langle a,d|\emptyset \rangle} + u_{\langle a,c|bd \rangle} - u_{\langle a,b|cd \rangle} + u_{\langle b,d|a \rangle} - u_{\langle c,d|b \rangle} \\
 &= (\delta_\emptyset - \delta_{\{d\}} - \delta_{\{a,b\}} + \delta_{\{b,d\}} - \delta_{\{b,c,d\}} + \delta_{\{a,b,c,d\}}) \\
 &\quad - (\delta_{\{b\}} - \delta_{\{b,c\}} - \delta_{\{b,d\}} + \delta_{\{c,d\}} - \delta_{\{a,c,d\}} + \delta_{\{a,b,c,d\}})
 \end{aligned}$$

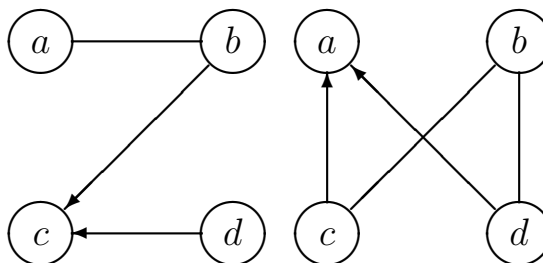



1.12.9.20 Differential imset (176)

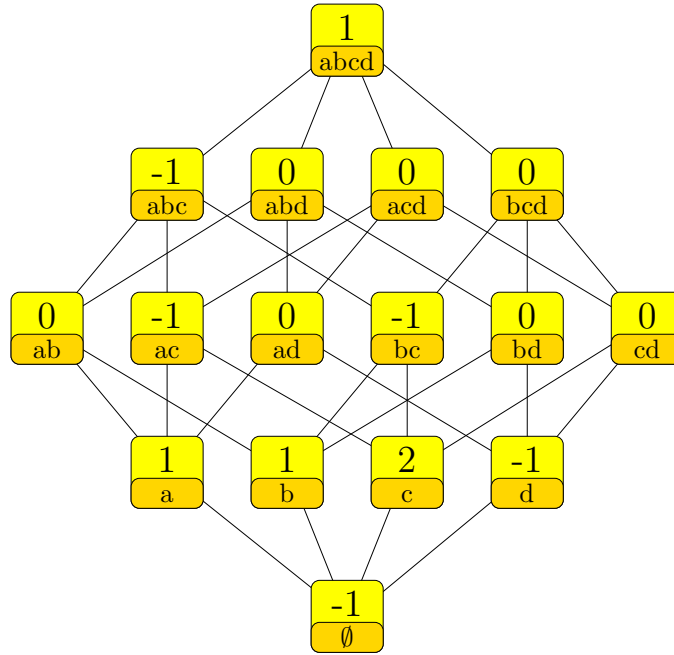

$$\begin{aligned}
 & -\delta_\emptyset + \delta_{\{a\}} + \delta_{\{b\}} + 2\delta_{\{c\}} - \delta_{\{d\}} - \delta_{\{a,c\}} - \delta_{\{b,c\}} - \delta_{\{a,b,c\}} + \delta_{\{a,b,c,d\}} \\
 &= -u_{\langle a,c|\emptyset \rangle} + u_{\langle a,d|\emptyset \rangle} - u_{\langle b,c|\emptyset \rangle} + u_{\langle c,d|ab \rangle} + u_{\langle b,d|a \rangle} \\
 &= (\delta_\emptyset + \delta_{\{c\}} - \delta_{\{d\}} - \delta_{\{a,c\}} - \delta_{\{b,c\}} + \delta_{\{a,b,c,d\}}) \\
 &\quad - (+2\delta_\emptyset - \delta_{\{a\}} - \delta_{\{b\}} - \delta_{\{c\}} + \delta_{\{a,b,c\}})
 \end{aligned}$$

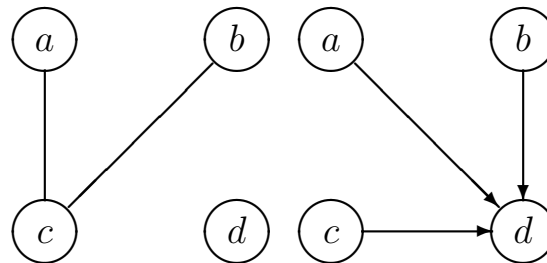

1.12.9.21 Differential imset (177)

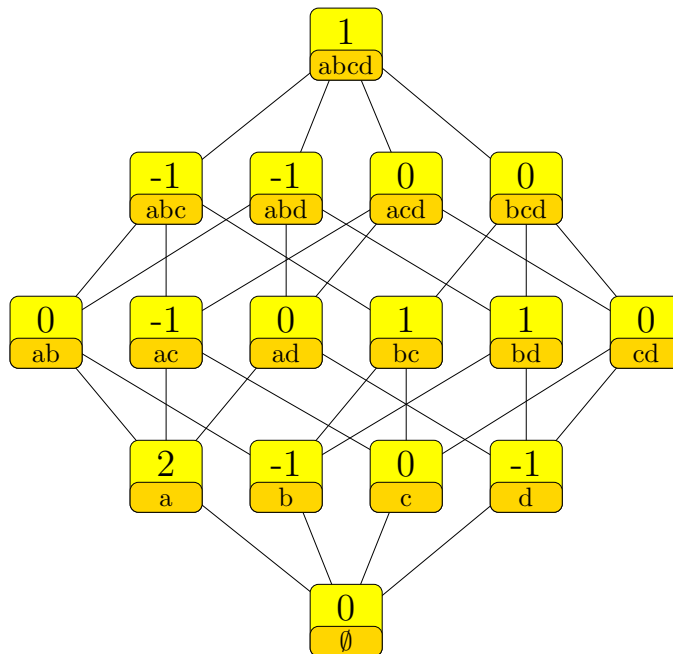

$$\begin{aligned}
 &+2\delta_{\{a\}} - \delta_{\{b\}} - \delta_{\{d\}} - \delta_{\{a,c\}} + \delta_{\{b,c\}} + \delta_{\{b,d\}} - \delta_{\{a,b,c\}} - \delta_{\{a,b,d\}} + \delta_{\{a,b,c,d\}} \\
 &= -u_{\langle a,b|\emptyset \rangle} + u_{\langle b,d|\emptyset \rangle} + u_{\langle c,d|ab \rangle} + u_{\langle b,c|a \rangle} - u_{\langle a,c|b \rangle} \\
 &= (\delta_{\emptyset} + \delta_{\{a\}} - \delta_{\{b\}} - \delta_{\{d\}} - \delta_{\{a,c\}} + \delta_{\{b,d\}} - \delta_{\{a,b,d\}} + \delta_{\{a,b,c,d\}}) \\
 &\quad - (\delta_{\emptyset} - \delta_{\{a\}} - \delta_{\{b,c\}} + \delta_{\{a,b,c\}})
 \end{aligned}$$

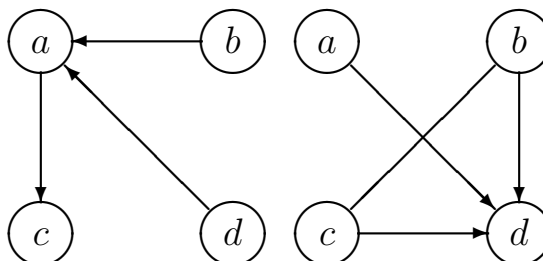

1.12.9.22 Differential imset (178)

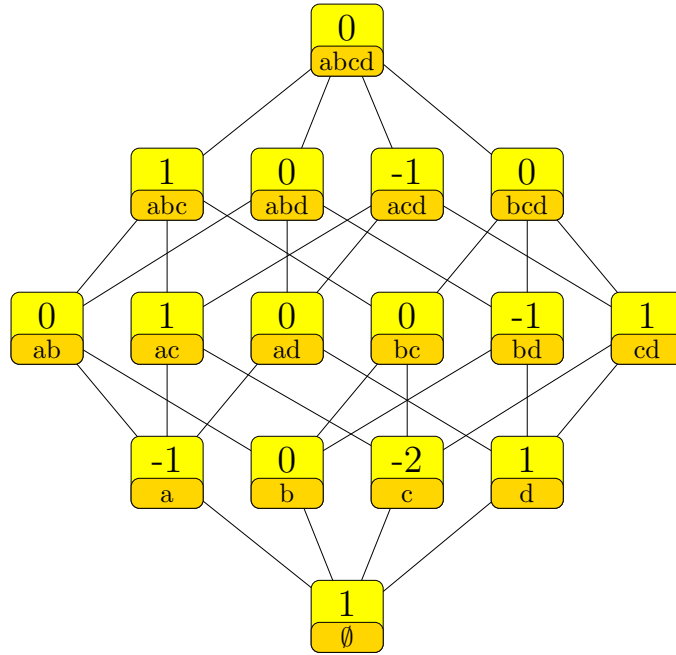

$$\begin{aligned}
 & \delta_\emptyset - \delta_{\{a\}} - 2\delta_{\{c\}} + \delta_{\{d\}} + \delta_{\{a,c\}} - \delta_{\{b,d\}} + \delta_{\{c,d\}} + \delta_{\{a,b,c\}} - \delta_{\{a,c,d\}} \\
 &= u_{\langle a,c|\emptyset \rangle} - u_{\langle b,d|ac \rangle} + u_{\langle b,c|ad \rangle} - u_{\langle a,d|c \rangle} + u_{\langle a,b|d \rangle} \\
 &= (\delta_\emptyset - \delta_{\{a\}} - \delta_{\{c\}} + \delta_{\{d\}} + \delta_{\{a,c\}} - \delta_{\{b,d\}} - \delta_{\{a,c,d\}} + \delta_{\{a,b,c,d\}}) \\
 &\quad - (\delta_{\{c\}} - \delta_{\{c,d\}} - \delta_{\{a,b,c\}} + \delta_{\{a,b,c,d\}})
 \end{aligned}$$

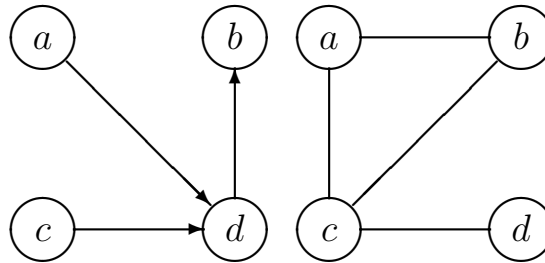

1.12.9.23 Differential imset (179)

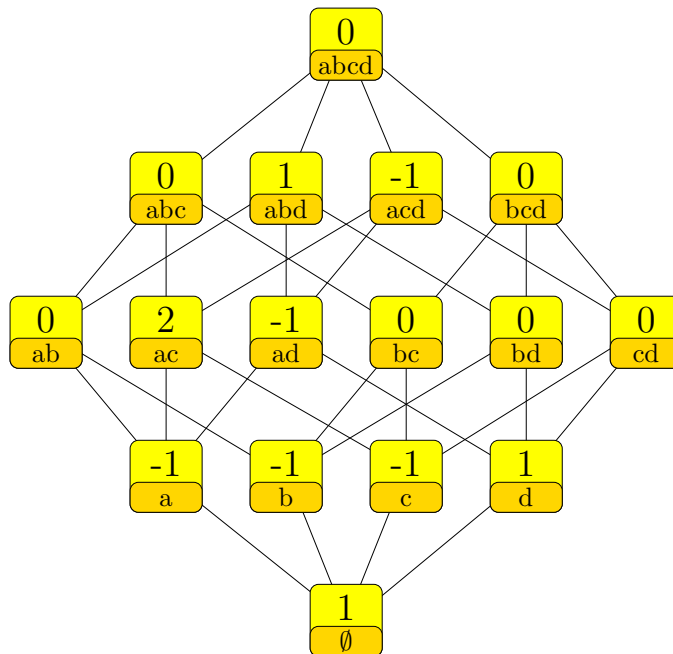

$$\begin{aligned}
 & \delta_\emptyset - \delta_{\{a\}} - \delta_{\{b\}} - \delta_{\{c\}} + \delta_{\{d\}} + 2\delta_{\{a,c\}} - \delta_{\{a,d\}} + \delta_{\{a,b,d\}} - \delta_{\{a,c,d\}} \\
 &= u_{\langle a,b|\emptyset \rangle} + u_{\langle a,c|\emptyset \rangle} - u_{\langle a,d|\emptyset \rangle} - u_{\langle c,d|ab \rangle} + u_{\langle b,d|ac \rangle} \\
 &= (+2\delta_\emptyset - \delta_{\{a\}} - \delta_{\{b\}} - \delta_{\{c\}} + \delta_{\{a,c\}} - \delta_{\{a,c,d\}} + \delta_{\{a,b,c,d\}}) \\
 &\quad - (\delta_\emptyset - \delta_{\{d\}} - \delta_{\{a,c\}} + \delta_{\{a,d\}} - \delta_{\{a,b,d\}} + \delta_{\{a,b,c,d\}})
 \end{aligned}$$

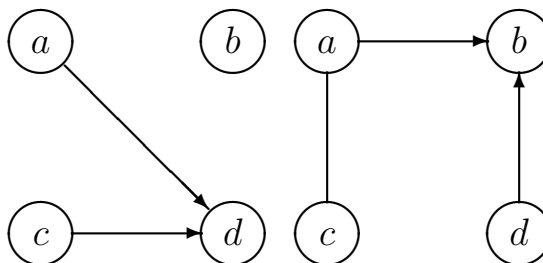

1.12.12 Number of nonzero values 12

1.12.12.1 Differential imset (180)

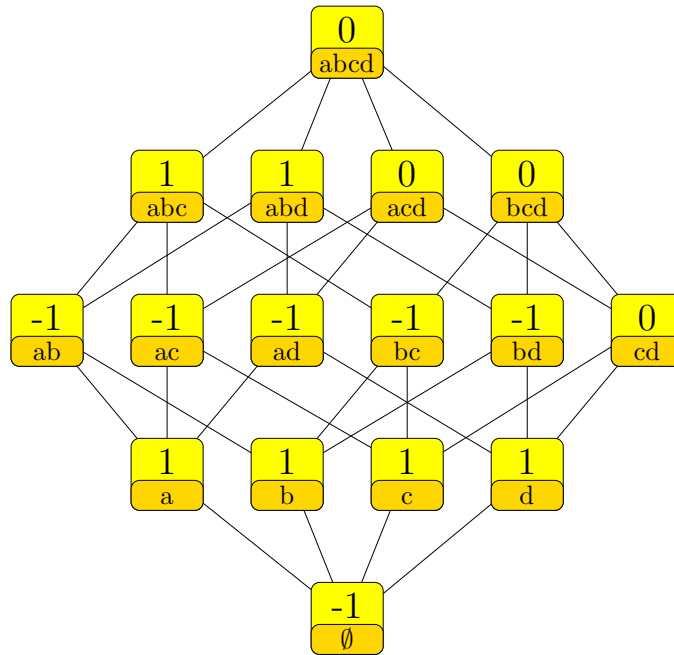

$$\begin{aligned}
 & -\delta_{\emptyset} + \delta_{\{a\}} + \delta_{\{b\}} + \delta_{\{c\}} + \delta_{\{d\}} - \delta_{\{a,b\}} - \delta_{\{a,c\}} - \delta_{\{a,d\}} - \delta_{\{b,c\}} - \delta_{\{b,d\}} + \delta_{\{a,b,c\}} + \delta_{\{a,b,d\}} \\
 &= -u_{\langle b,d|\emptyset \rangle} + u_{\langle b,d|a \rangle} + u_{\langle a,b|c \rangle} \\
 &= (\delta_{\{a\}} + \delta_{\{c\}} - \delta_{\{a,c\}} - \delta_{\{a,d\}} - \delta_{\{b,c\}} + \delta_{\{a,b,c,d\}}) \\
 &\quad - (\delta_{\emptyset} - \delta_{\{b\}} - \delta_{\{d\}} + \delta_{\{a,b\}} + \delta_{\{b,d\}} - \delta_{\{a,b,c\}} - \delta_{\{a,b,d\}} + \delta_{\{a,b,c,d\}}) \\
 &= (\delta_{\{b\}} + \delta_{\{c\}} - \delta_{\{a,c\}} - \delta_{\{b,c\}} - \delta_{\{b,d\}} + \delta_{\{a,b,c,d\}}) \\
 &\quad - (\delta_{\emptyset} - \delta_{\{a\}} - \delta_{\{d\}} + \delta_{\{a,b\}} + \delta_{\{a,d\}} - \delta_{\{a,b,c\}} - \delta_{\{a,b,d\}} + \delta_{\{a,b,c,d\}})
 \end{aligned}$$

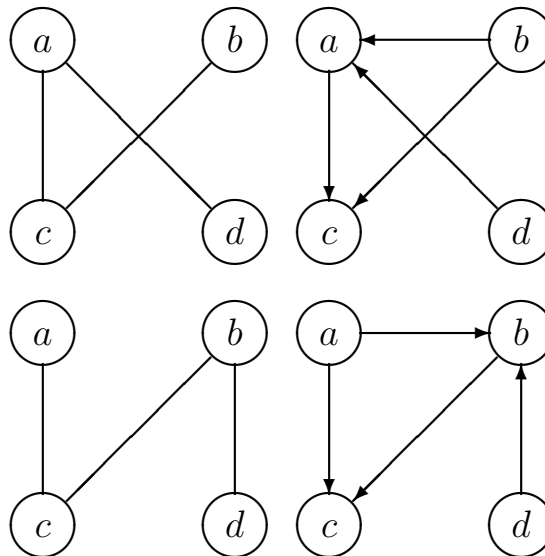

1.12.12.2 Differential imset (181)

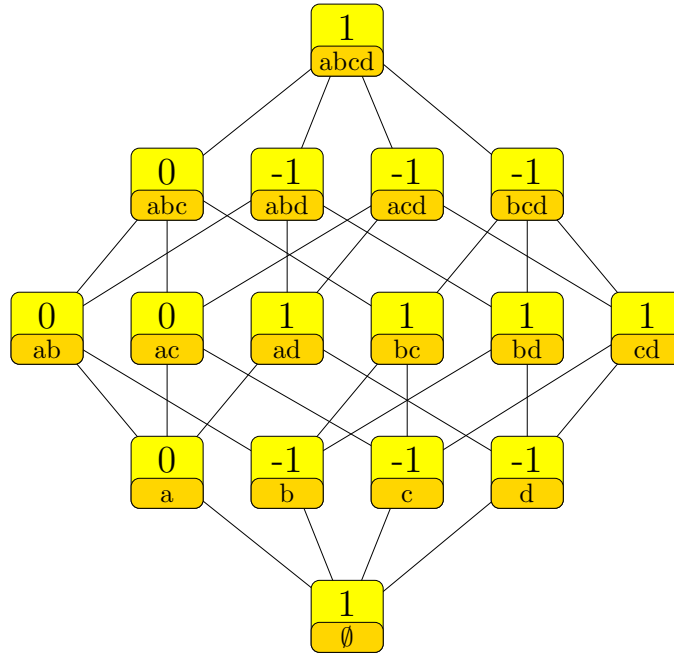

$$\begin{aligned}
 & \delta_\emptyset - \delta_{\{b\}} - \delta_{\{c\}} - \delta_{\{d\}} + \delta_{\{a,d\}} + \delta_{\{b,c\}} + \delta_{\{b,d\}} + \delta_{\{c,d\}} - \delta_{\{a,b,d\}} - \delta_{\{a,c,d\}} - \delta_{\{b,c,d\}} + \delta_{\{a,b,c,d\}} \\
 &= u_{\langle b,c|\emptyset \rangle} + u_{\langle a,c|bd \rangle} - u_{\langle a,c|d \rangle} \\
 &= (\delta_\emptyset - \delta_{\{b\}} - \delta_{\{c\}} + \delta_{\{b,c\}} + \delta_{\{b,d\}} - \delta_{\{a,b,d\}} - \delta_{\{b,c,d\}} + \delta_{\{a,b,c,d\}}) \\
 &\quad - (\delta_{\{d\}} - \delta_{\{a,d\}} - \delta_{\{c,d\}} + \delta_{\{a,c,d\}}) \\
 &= (\delta_\emptyset - \delta_{\{b\}} - \delta_{\{d\}} + \delta_{\{a,d\}} + \delta_{\{b,d\}} - \delta_{\{a,b,d\}} - \delta_{\{a,c,d\}} + \delta_{\{a,b,c,d\}}) \\
 &\quad - (\delta_{\{c\}} - \delta_{\{b,c\}} - \delta_{\{c,d\}} + \delta_{\{b,c,d\}})
 \end{aligned}$$

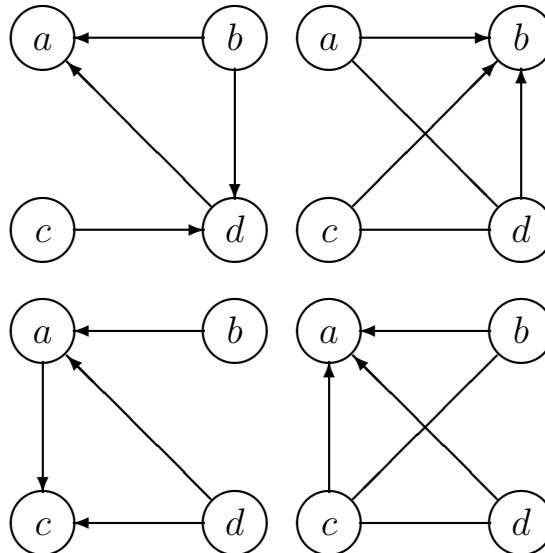

1.12.12.3 Differential imset (182)

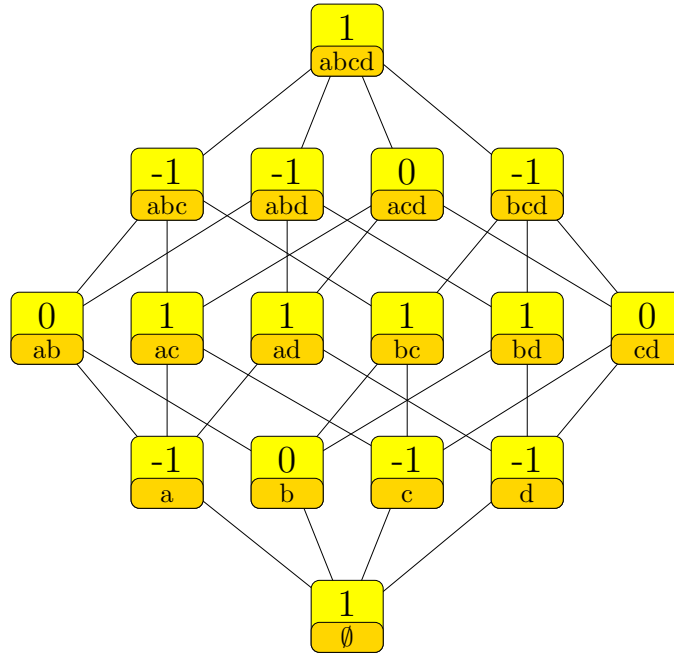

$$\begin{aligned}
 & \delta_\emptyset - \delta_{\{a\}} - \delta_{\{c\}} - \delta_{\{d\}} + \delta_{\{a,c\}} + \delta_{\{a,d\}} + \delta_{\{b,c\}} + \delta_{\{b,d\}} - \delta_{\{a,b,c\}} - \delta_{\{a,b,d\}} - \delta_{\{b,c,d\}} + \delta_{\{a,b,c,d\}} \\
 &= u_{\langle a,d|\emptyset \rangle} + u_{\langle a,c|bd \rangle} - u_{\langle a,b|c \rangle} \\
 &= (\delta_\emptyset - \delta_{\{a\}} - \delta_{\{d\}} + \delta_{\{a,d\}} + \delta_{\{b,d\}} - \delta_{\{a,b,d\}} - \delta_{\{b,c,d\}} + \delta_{\{a,b,c,d\}}) \\
 &\quad - (\delta_{\{c\}} - \delta_{\{a,c\}} - \delta_{\{b,c\}} + \delta_{\{a,b,c\}})
 \end{aligned}$$

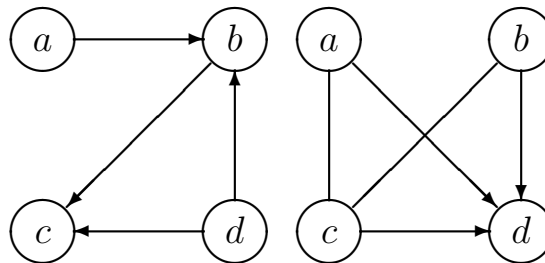

### 1.14 Squared Euclidean length 14

#### 1.14.8 Number of nonzero values 8

##### 1.14.8.1 Differential imset (183)

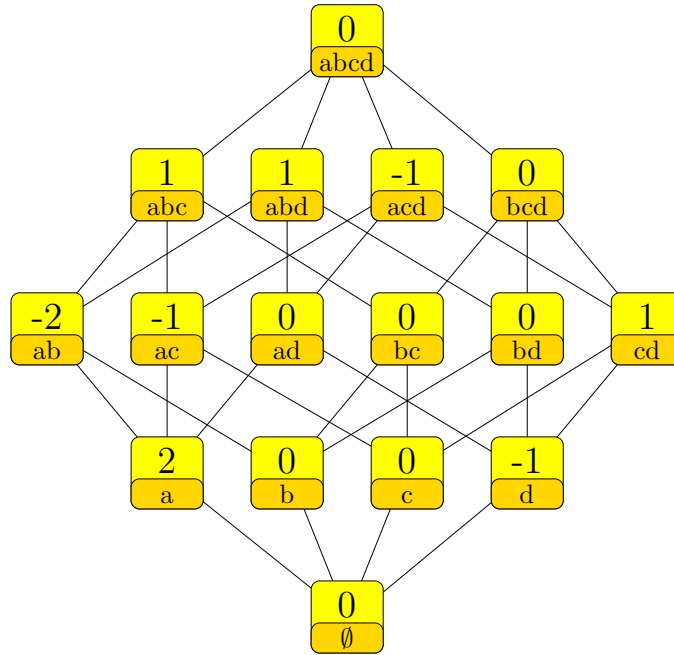

$$\begin{aligned}
 &+2\delta_{\{a\}} - \delta_{\{d\}} - 2\delta_{\{a,b\}} - \delta_{\{a,c\}} + \delta_{\{c,d\}} + \delta_{\{a,b,c\}} + \delta_{\{a,b,d\}} - \delta_{\{a,c,d\}} \\
 &= u_{\langle b,c|a \rangle} + u_{\langle b,d|a \rangle} - u_{\langle a,c|d \rangle} \\
 &= (\delta_{\emptyset} + \delta_{\{a\}} - \delta_{\{c\}} - \delta_{\{d\}} - \delta_{\{a,b\}} + \delta_{\{c,d\}} - \delta_{\{a,c,d\}} + \delta_{\{a,b,c,d\}}) \\
 &\quad - (\delta_{\emptyset} - \delta_{\{a\}} - \delta_{\{c\}} + \delta_{\{a,b\}} + \delta_{\{a,c\}} - \delta_{\{a,b,c\}} - \delta_{\{a,b,d\}} + \delta_{\{a,b,c,d\}})
 \end{aligned}$$

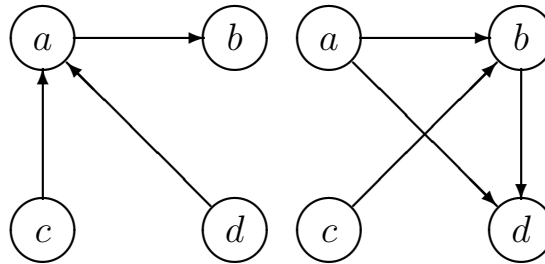



1.14.8.2 Differential imset (184)

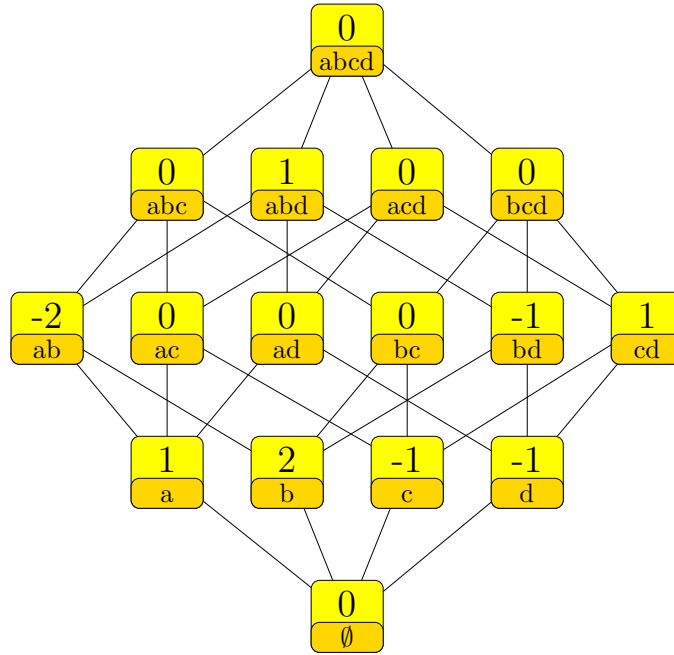

$$\begin{aligned}
 & \delta_{\{a\}} + 2\delta_{\{b\}} - \delta_{\{c\}} - \delta_{\{d\}} - 2\delta_{\{a,b\}} - \delta_{\{b,d\}} + \delta_{\{c,d\}} + \delta_{\{a,b,d\}} \\
 &= -u_{\langle a,b|\emptyset \rangle} + u_{\langle c,d|\emptyset \rangle} + u_{\langle a,d|b \rangle} \\
 &= (\delta_{\emptyset} + \delta_{\{b\}} - \delta_{\{c\}} - \delta_{\{a,b\}} - \delta_{\{b,d\}} + \delta_{\{a,b,c,d\}}) \\
 &\quad - (\delta_{\emptyset} - \delta_{\{a\}} - \delta_{\{b\}} + \delta_{\{d\}} + \delta_{\{a,b\}} - \delta_{\{c,d\}} - \delta_{\{a,b,d\}} + \delta_{\{a,b,c,d\}})
 \end{aligned}$$

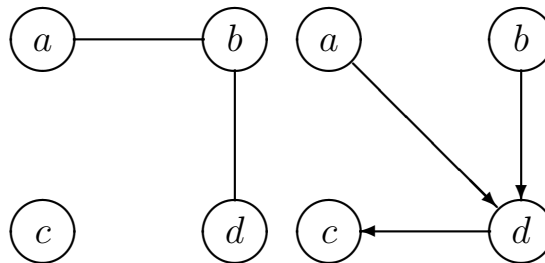

1.14.8.3 Differential imset (185)

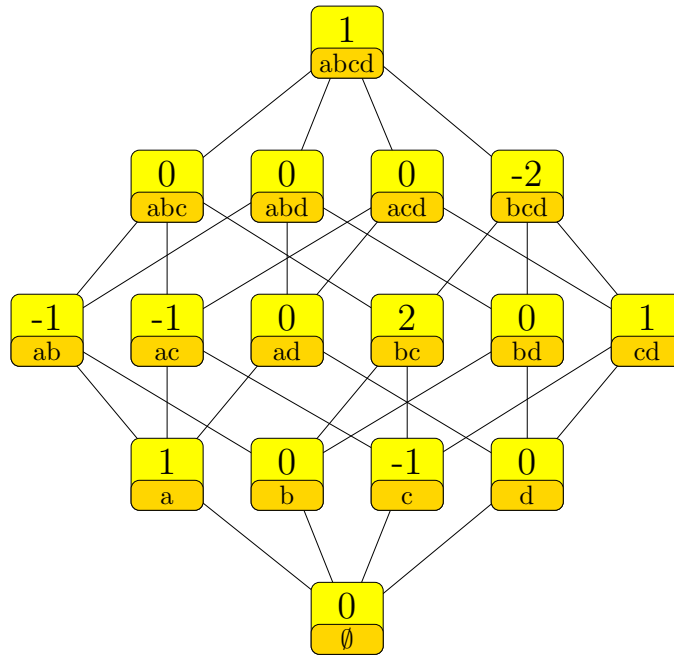

$$\begin{aligned}
 & \delta_{\{a\}} - \delta_{\{c\}} - \delta_{\{a,b\}} - \delta_{\{a,c\}} + 2\delta_{\{b,c\}} + \delta_{\{c,d\}} - 2\delta_{\{b,c,d\}} + \delta_{\{a,b,c,d\}} \\
 &= u_{\langle a,d|bc \rangle} + u_{\langle b,c|a \rangle} - u_{\langle b,d|c \rangle} \\
 &= (\delta_{\{a\}} - \delta_{\{a,b\}} - \delta_{\{a,c\}} + \delta_{\{b,c\}} - \delta_{\{b,c,d\}} + \delta_{\{a,b,c,d\}}) \\
 &\quad - (\delta_{\{c\}} - \delta_{\{b,c\}} - \delta_{\{c,d\}} + \delta_{\{b,c,d\}})
 \end{aligned}$$

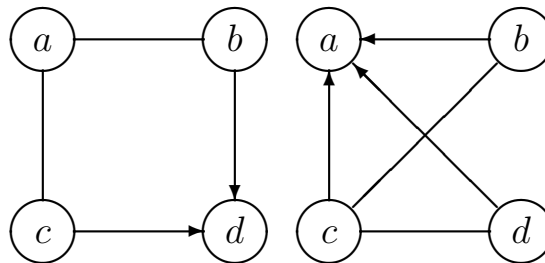

1.14.8.4 Differential imset (186)

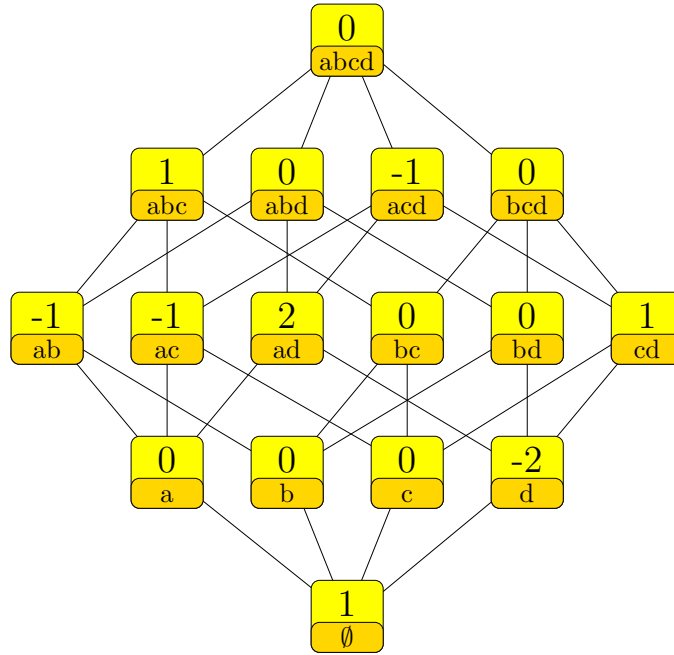

$$\begin{aligned}
 & \delta_\emptyset - 2\delta_{\{d\}} - \delta_{\{a,b\}} - \delta_{\{a,c\}} + 2\delta_{\{a,d\}} + \delta_{\{c,d\}} + \delta_{\{a,b,c\}} - \delta_{\{a,c,d\}} \\
 &= u_{\langle a,d|\emptyset \rangle} + u_{\langle b,c|a \rangle} - u_{\langle a,c|d \rangle} \\
 &= (\delta_\emptyset - \delta_{\{d\}} - \delta_{\{a,b\}} + \delta_{\{a,d\}} - \delta_{\{a,c,d\}} + \delta_{\{a,b,c,d\}}) \\
 &\quad - (\delta_{\{d\}} + \delta_{\{a,c\}} - \delta_{\{a,d\}} - \delta_{\{c,d\}} - \delta_{\{a,b,c\}} + \delta_{\{a,b,c,d\}})
 \end{aligned}$$

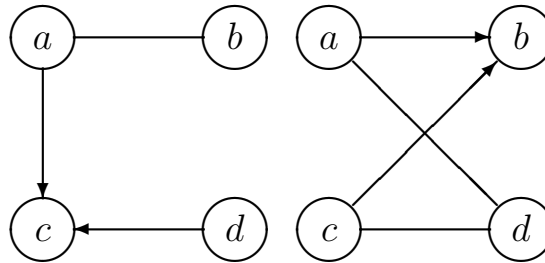

1.14.8.5 Differential imset (187)

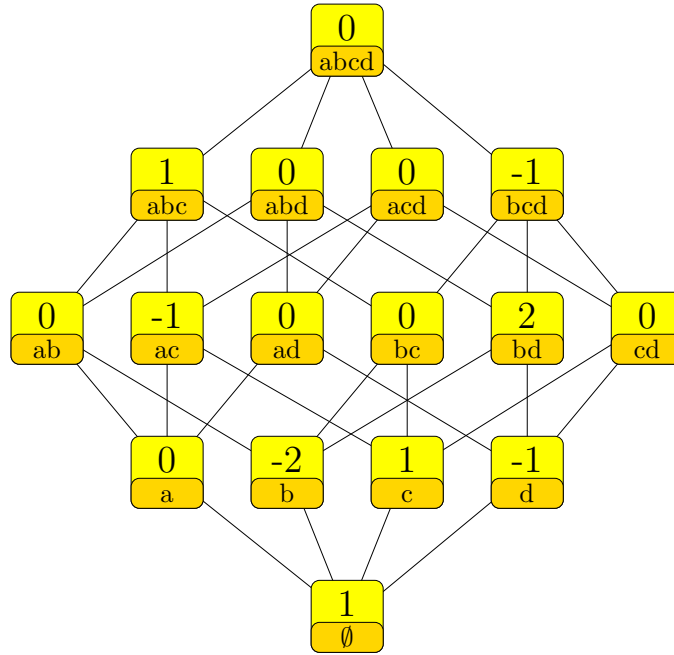

$$\begin{aligned}
 & \delta_\emptyset - 2\delta_{\{b\}} + \delta_{\{c\}} - \delta_{\{d\}} - \delta_{\{a,c\}} + 2\delta_{\{b,d\}} + \delta_{\{a,b,c\}} - \delta_{\{b,c,d\}} \\
 &= u_{\langle b,d|\emptyset \rangle} + u_{\langle a,b|c \rangle} - u_{\langle c,d|b \rangle} \\
 &= (\delta_\emptyset - \delta_{\{b\}} + \delta_{\{c\}} - \delta_{\{d\}} - \delta_{\{a,c\}} + \delta_{\{b,d\}} - \delta_{\{b,c,d\}} + \delta_{\{a,b,c,d\}}) \\
 &\quad - (\delta_{\{b\}} - \delta_{\{b,d\}} - \delta_{\{a,b,c\}} + \delta_{\{a,b,c,d\}})
 \end{aligned}$$

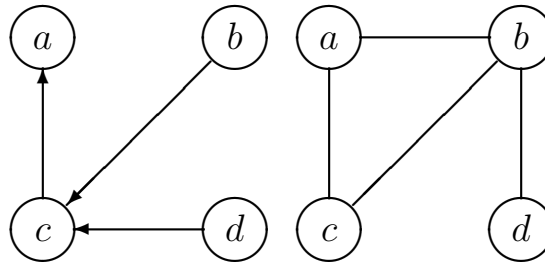

1.14.11 Number of nonzero values 11

1.14.11.1 Differential imset (188)

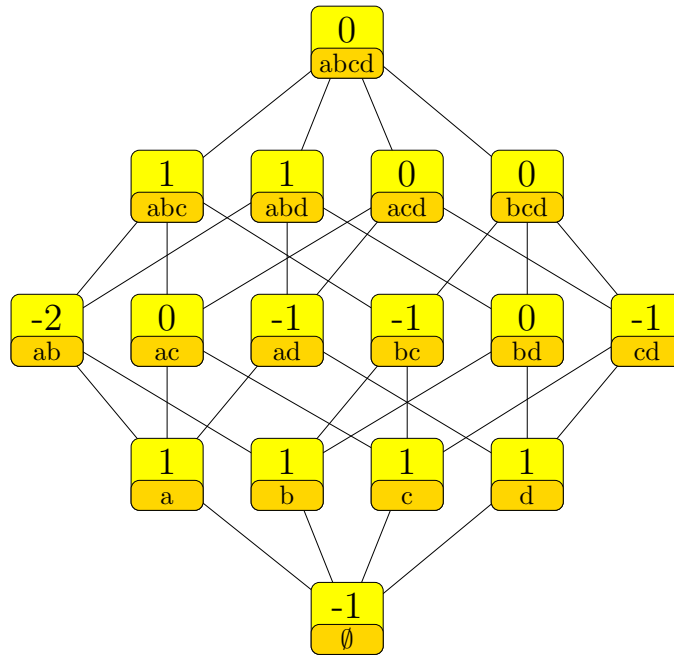

$$\begin{aligned}
 & -\delta_{\emptyset} + \delta_{\{a\}} + \delta_{\{b\}} + \delta_{\{c\}} + \delta_{\{d\}} - 2\delta_{\{a,b\}} - \delta_{\{a,d\}} - \delta_{\{b,c\}} - \delta_{\{c,d\}} + \delta_{\{a,b,c\}} + \delta_{\{a,b,d\}} \\
 &= -u_{\langle c,d|\emptyset \rangle} + u_{\langle b,d|a \rangle} + u_{\langle a,c|b \rangle} \\
 &= (\delta_{\{c\}} + \delta_{\{d\}} - \delta_{\{a,d\}} - \delta_{\{b,c\}} - \delta_{\{c,d\}} + \delta_{\{a,b,c,d\}}) \\
 &\quad - (\delta_{\emptyset} - \delta_{\{a\}} - \delta_{\{b\}} + 2\delta_{\{a,b\}} - \delta_{\{a,b,c\}} - \delta_{\{a,b,d\}} + \delta_{\{a,b,c,d\}})
 \end{aligned}$$

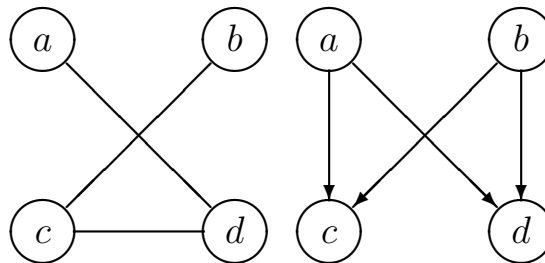

1.14.11.2 Differential imset (189)

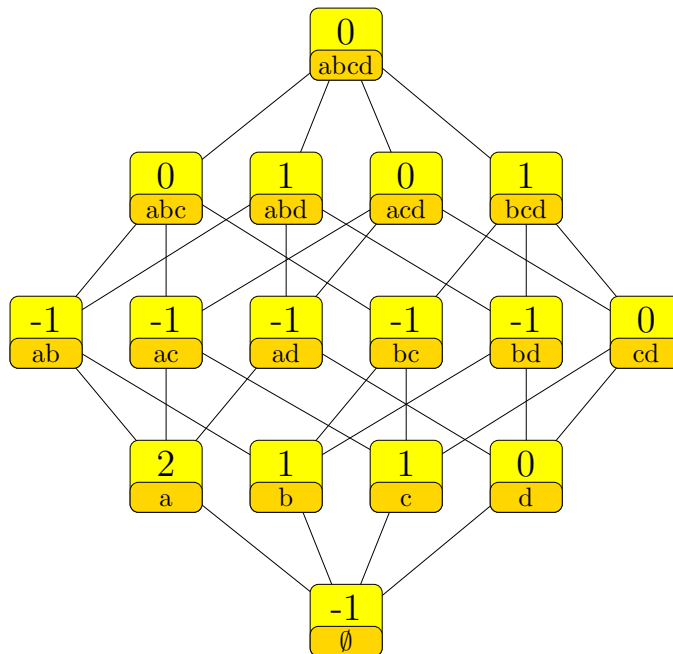

$$\begin{aligned}
 & -\delta_{\emptyset} + 2\delta_{\{a\}} + \delta_{\{b\}} + \delta_{\{c\}} - \delta_{\{a,b\}} - \delta_{\{a,c\}} - \delta_{\{a,d\}} - \delta_{\{b,c\}} - \delta_{\{b,d\}} + \delta_{\{a,b,d\}} + \delta_{\{b,c,d\}} \\
 & = -u_{\langle a,c|\emptyset \rangle} + u_{\langle b,d|a \rangle} + u_{\langle c,d|b \rangle} \\
 & = (\delta_{\{a\}} + \delta_{\{c\}} - \delta_{\{a,c\}} - \delta_{\{a,d\}} - \delta_{\{b,c\}} + \delta_{\{a,b,c,d\}}) \\
 & \quad - (\delta_{\emptyset} - \delta_{\{a\}} - \delta_{\{b\}} + \delta_{\{a,b\}} + \delta_{\{b,d\}} - \delta_{\{a,b,d\}} - \delta_{\{b,c,d\}} + \delta_{\{a,b,c,d\}})
 \end{aligned}$$

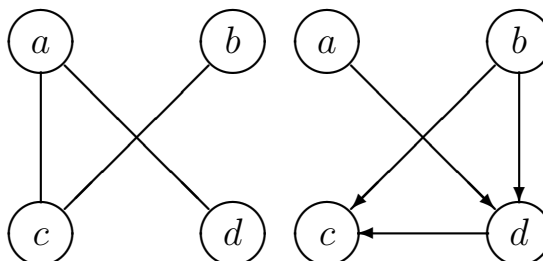

1.14.11.3 Differential imset (190)

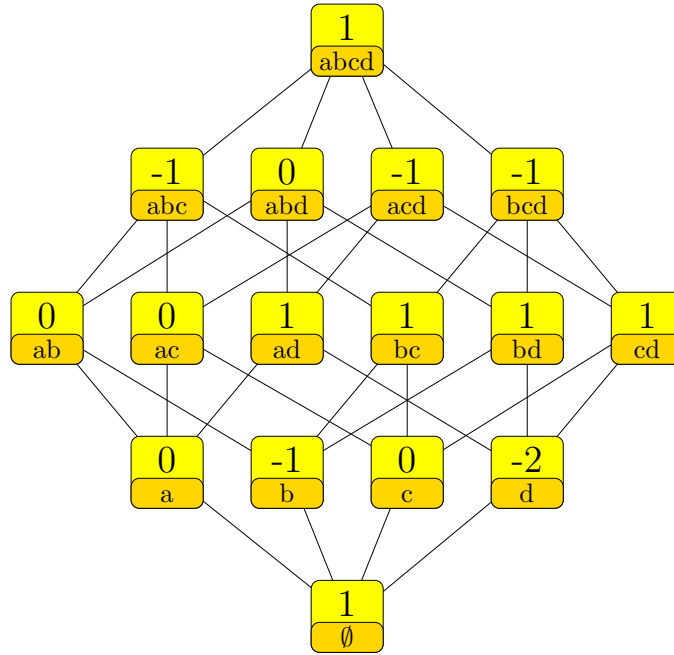

$$\begin{aligned}
 & \delta_{\emptyset} - \delta_{\{b\}} - 2\delta_{\{d\}} + \delta_{\{a,d\}} + \delta_{\{b,c\}} + \delta_{\{b,d\}} + \delta_{\{c,d\}} - \delta_{\{a,b,c\}} - \delta_{\{a,c,d\}} - \delta_{\{b,c,d\}} + \delta_{\{a,b,c,d\}} \\
 &= u_{\langle b,d|\emptyset \rangle} + u_{\langle a,d|bc \rangle} - u_{\langle a,c|d \rangle} \\
 &= (\delta_{\emptyset} - \delta_{\{b\}} - \delta_{\{d\}} + \delta_{\{b,c\}} + \delta_{\{b,d\}} - \delta_{\{a,b,c\}} - \delta_{\{b,c,d\}} + \delta_{\{a,b,c,d\}}) \\
 &\quad - (\delta_{\{d\}} - \delta_{\{a,d\}} - \delta_{\{c,d\}} + \delta_{\{a,c,d\}})
 \end{aligned}$$

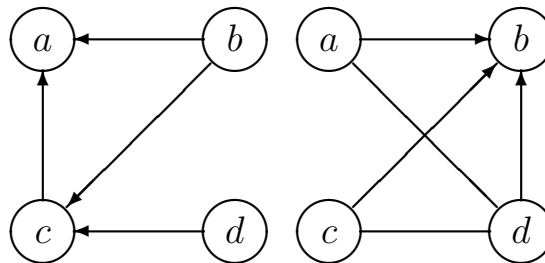

1.14.11.4 Differential imset (191)

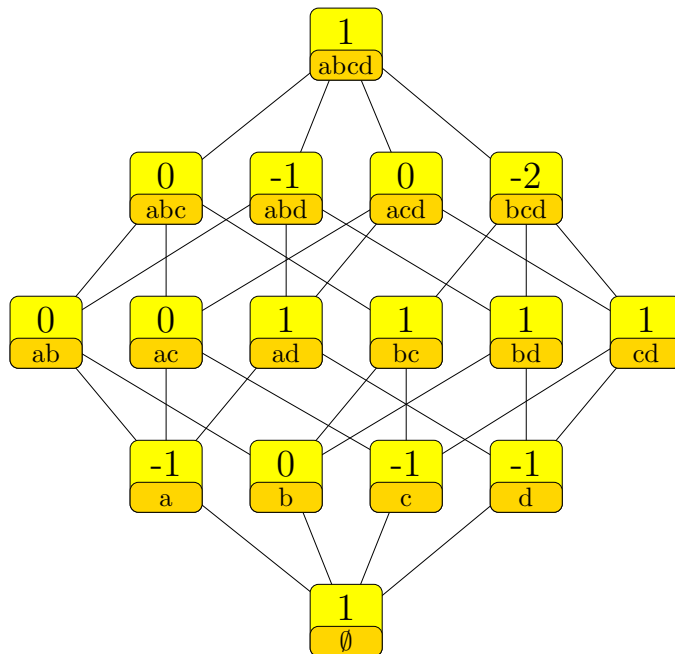

$$\begin{aligned}
 & \delta_\emptyset - \delta_{\{a\}} - \delta_{\{c\}} - \delta_{\{d\}} + \delta_{\{a,d\}} + \delta_{\{b,c\}} + \delta_{\{b,d\}} + \delta_{\{c,d\}} - \delta_{\{a,b,d\}} - 2\delta_{\{b,c,d\}} + \delta_{\{a,b,c,d\}} \\
 &= u_{\langle a,d|\emptyset \rangle} + u_{\langle a,c|bd \rangle} - u_{\langle b,d|c \rangle} \\
 &= (\delta_\emptyset - \delta_{\{a\}} - \delta_{\{d\}} + \delta_{\{a,d\}} + \delta_{\{b,d\}} - \delta_{\{a,b,d\}} - \delta_{\{b,c,d\}} + \delta_{\{a,b,c,d\}}) \\
 &\quad - (\delta_{\{c\}} - \delta_{\{b,c\}} - \delta_{\{c,d\}} + \delta_{\{b,c,d\}})
 \end{aligned}$$

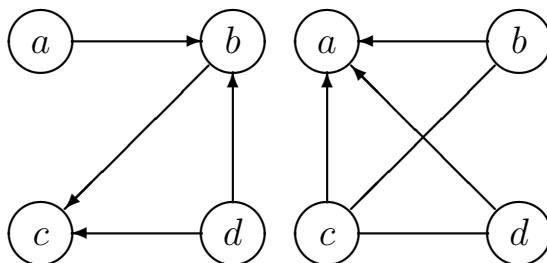



1.14.11.5 Differential imset (192)

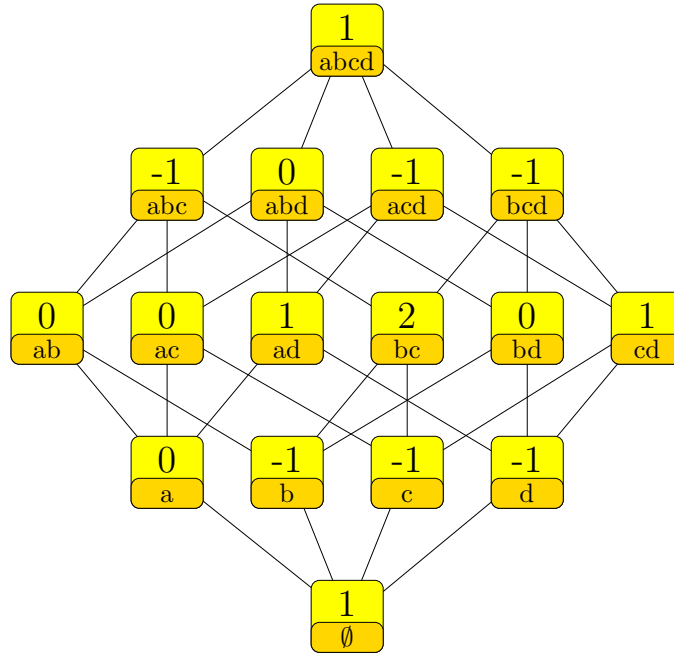

$$\begin{aligned}
 & \delta_\emptyset - \delta_{\{b\}} - \delta_{\{c\}} - \delta_{\{d\}} + \delta_{\{a,d\}} + 2\delta_{\{b,c\}} + \delta_{\{c,d\}} - \delta_{\{a,b,c\}} - \delta_{\{a,c,d\}} - \delta_{\{b,c,d\}} + \delta_{\{a,b,c,d\}} \\
 &= u_{\langle b,c|\emptyset \rangle} + u_{\langle a,d|bc \rangle} - u_{\langle a,c|d \rangle} \\
 &= (\delta_\emptyset - \delta_{\{b\}} - \delta_{\{c\}} + 2\delta_{\{b,c\}} - \delta_{\{a,b,c\}} - \delta_{\{b,c,d\}} + \delta_{\{a,b,c,d\}}) \\
 &\quad - (\delta_{\{d\}} - \delta_{\{a,d\}} - \delta_{\{c,d\}} + \delta_{\{a,c,d\}})
 \end{aligned}$$

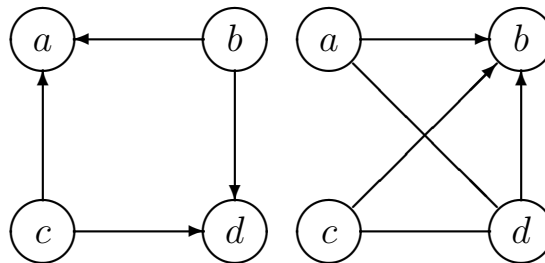

### 1.16 Squared Euclidean length 16

#### 1.16.7 Number of nonzero values 7

##### 1.16.7.1 Differential imset (193)

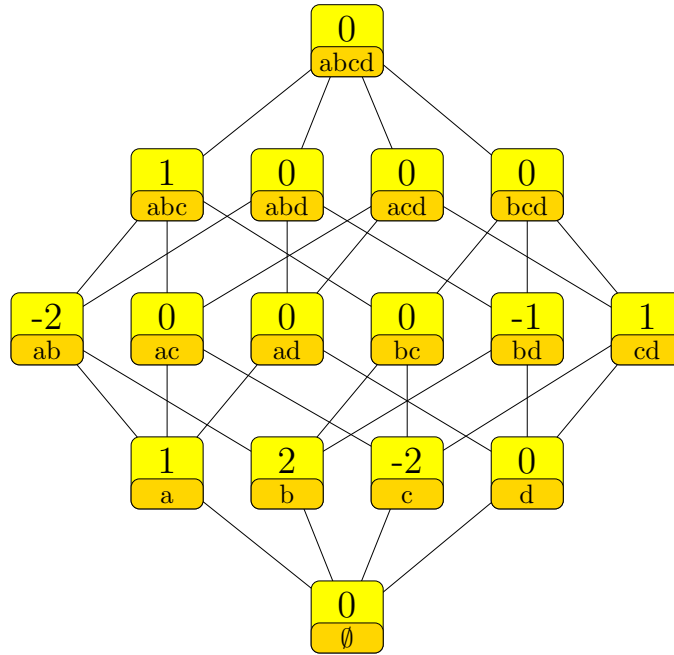

$$\begin{aligned}
 & \delta_{\{a\}} + 2\delta_{\{b\}} - 2\delta_{\{c\}} - 2\delta_{\{a,b\}} - \delta_{\{b,d\}} + \delta_{\{c,d\}} + \delta_{\{a,b,c\}} \\
 &= -u_{\langle a,b|\emptyset \rangle} + u_{\langle a,c|\emptyset \rangle} - u_{\langle b,d|\emptyset \rangle} + u_{\langle c,d|\emptyset \rangle} + u_{\langle b,c|a \rangle} \\
 &= (\delta_{\emptyset} + \delta_{\{b\}} - \delta_{\{c\}} - \delta_{\{a,b\}} - \delta_{\{b,d\}} + \delta_{\{a,b,c,d\}}) \\
 &\quad - (\delta_{\emptyset} - \delta_{\{a\}} - \delta_{\{b\}} + \delta_{\{c\}} + \delta_{\{a,b\}} - \delta_{\{c,d\}} - \delta_{\{a,b,c\}} + \delta_{\{a,b,c,d\}})
 \end{aligned}$$

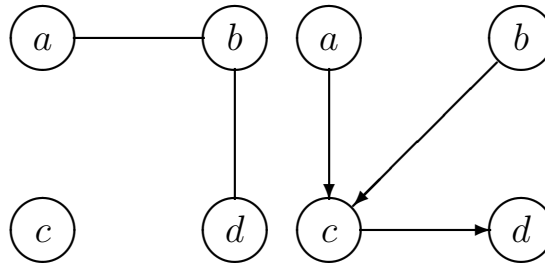

1.16.7.2 Differential imset (194)

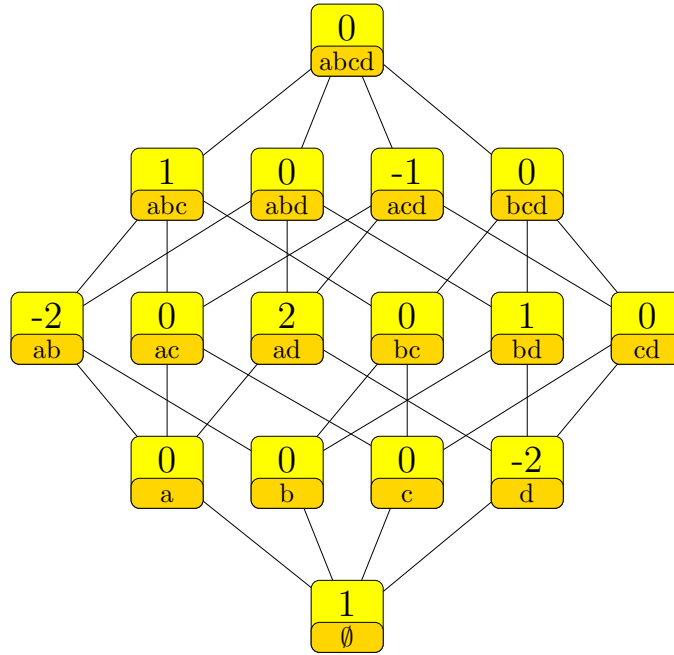

$$\begin{aligned}
 & \delta_\emptyset - 2\delta_{\{d\}} - 2\delta_{\{a,b\}} + 2\delta_{\{a,d\}} + \delta_{\{b,d\}} + \delta_{\{a,b,c\}} - \delta_{\{a,c,d\}} \\
 &= u_{\langle a,d|\emptyset \rangle} - u_{\langle c,d|ab \rangle} + u_{\langle b,d|ac \rangle} + u_{\langle b,c|a \rangle} - u_{\langle a,b|d \rangle} \\
 &= (\delta_\emptyset - \delta_{\{d\}} - \delta_{\{a,b\}} + \delta_{\{a,d\}} - \delta_{\{a,c,d\}} + \delta_{\{a,b,c,d\}}) \\
 &\quad - (\delta_{\{d\}} + \delta_{\{a,b\}} - \delta_{\{a,d\}} - \delta_{\{b,d\}} - \delta_{\{a,b,c\}} + \delta_{\{a,b,c,d\}})
 \end{aligned}$$

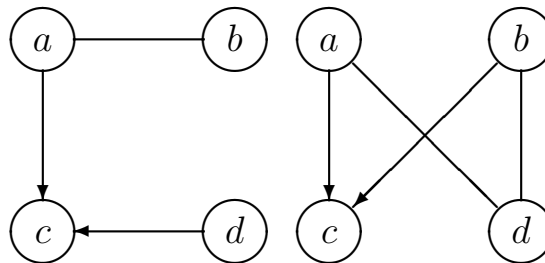

1.16.7.3 Differential imset (195)

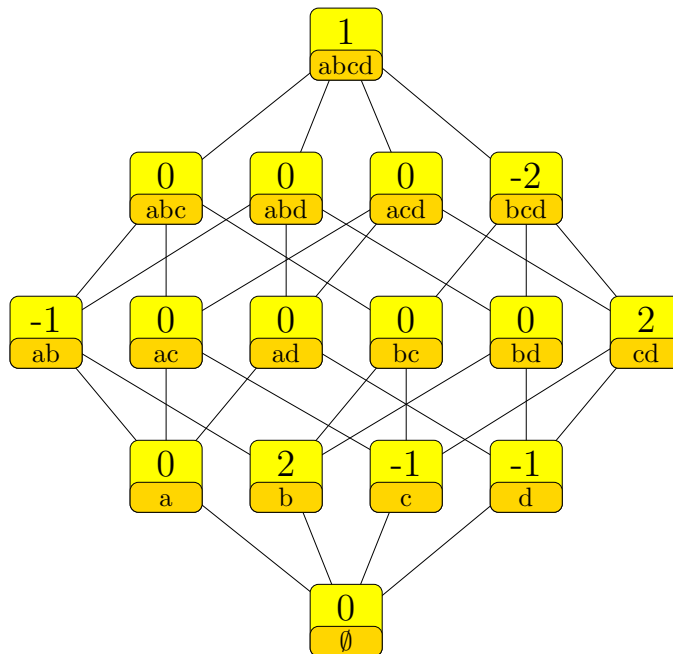

$$\begin{aligned}
 &+2\delta_{\{b\}} - \delta_{\{c\}} - \delta_{\{d\}} - \delta_{\{a,b\}} + 2\delta_{\{c,d\}} - 2\delta_{\{b,c,d\}} + \delta_{\{a,b,c,d\}} \\
 &= -u_{\langle b,c|\emptyset \rangle} + u_{\langle c,d|\emptyset \rangle} + u_{\langle a,d|bc \rangle} + u_{\langle a,c|b \rangle} - u_{\langle b,d|c \rangle} \\
 &= (\delta_{\emptyset} + \delta_{\{b\}} - \delta_{\{c\}} - \delta_{\{d\}} - \delta_{\{a,b\}} + \delta_{\{c,d\}} - \delta_{\{b,c,d\}} + \delta_{\{a,b,c,d\}}) \\
 &\quad - (\delta_{\emptyset} - \delta_{\{b\}} - \delta_{\{c,d\}} + \delta_{\{b,c,d\}})
 \end{aligned}$$

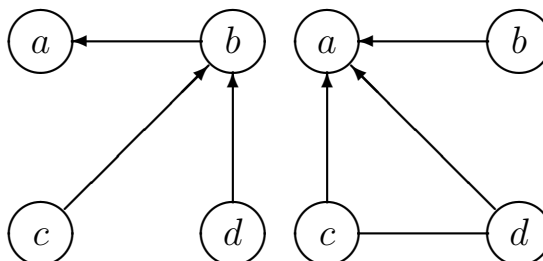

1.16.8 Number of nonzero values 8

1.16.8.1 Differential imset (196)

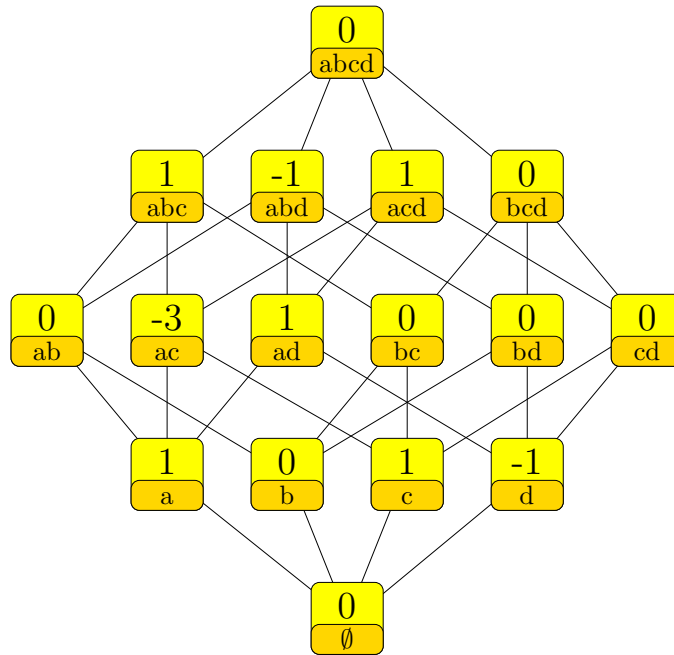

$$\begin{aligned}
 & \delta_{\{a\}} + \delta_{\{c\}} - \delta_{\{d\}} - 3\delta_{\{a,c\}} + \delta_{\{a,d\}} + \delta_{\{a,b,c\}} - \delta_{\{a,b,d\}} + \delta_{\{a,c,d\}} \\
 &= -u_{\langle a,c|\emptyset \rangle} + u_{\langle a,d|\emptyset \rangle} + u_{\langle c,d|ab \rangle} - u_{\langle b,d|ac \rangle} + u_{\langle b,c|a \rangle} \\
 &= (\delta_{\emptyset} - \delta_{\{d\}} - \delta_{\{a,c\}} + \delta_{\{a,d\}} - \delta_{\{a,b,d\}} + \delta_{\{a,b,c,d\}}) \\
 &\quad - (\delta_{\emptyset} - \delta_{\{a\}} - \delta_{\{c\}} + 2\delta_{\{a,c\}} - \delta_{\{a,b,c\}} - \delta_{\{a,c,d\}} + \delta_{\{a,b,c,d\}})
 \end{aligned}$$

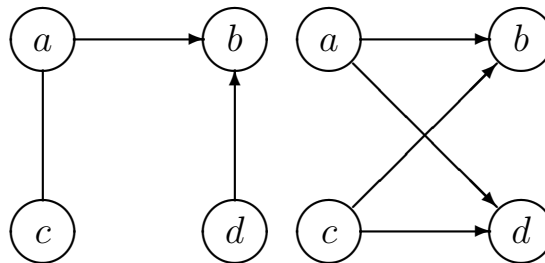

1.16.8.2 Differential imset (197)

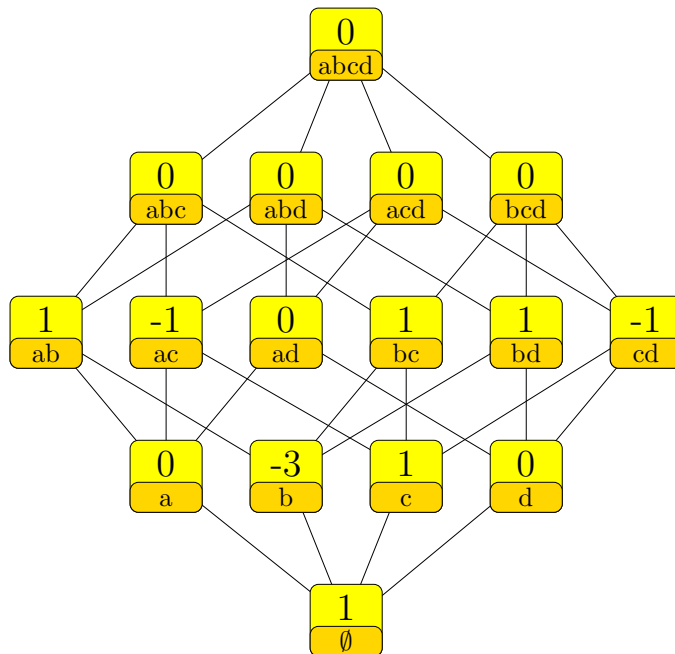

$$\begin{aligned}
 & \delta_\emptyset - 3\delta_{\{b\}} + \delta_{\{c\}} + \delta_{\{a,b\}} - \delta_{\{a,c\}} + \delta_{\{b,c\}} + \delta_{\{b,d\}} - \delta_{\{c,d\}} \\
 &= u_{\langle a,b|\emptyset \rangle} - u_{\langle a,c|\emptyset \rangle} + u_{\langle b,c|\emptyset \rangle} + u_{\langle b,d|\emptyset \rangle} - u_{\langle c,d|\emptyset \rangle} \\
 &= (\delta_\emptyset - \delta_{\{b\}} + \delta_{\{c\}} - \delta_{\{a,c\}} - \delta_{\{c,d\}} + \delta_{\{a,b,c,d\}}) \\
 &\quad - (+2\delta_{\{b\}} - \delta_{\{a,b\}} - \delta_{\{b,c\}} - \delta_{\{b,d\}} + \delta_{\{a,b,c,d\}})
 \end{aligned}$$

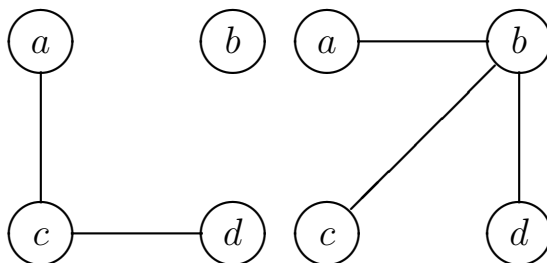

1.16.10 Number of nonzero values 10

1.16.10.1 Differential imset (198)

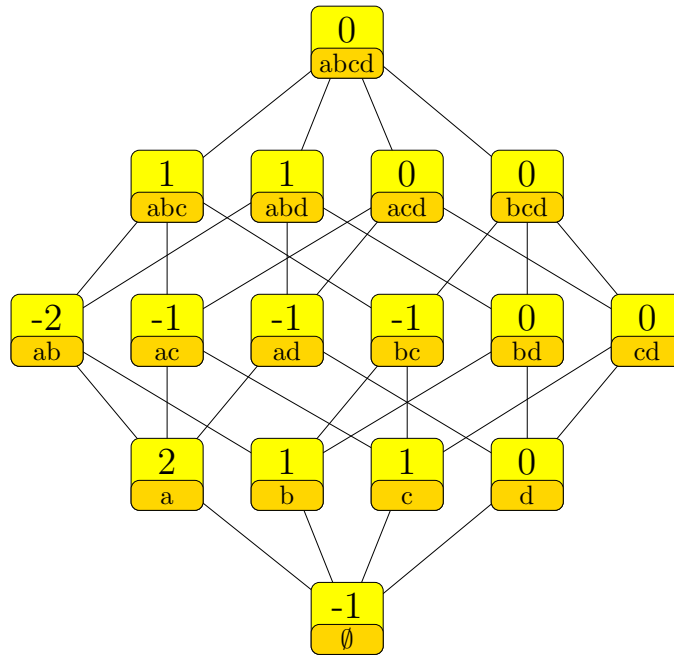

$$\begin{aligned}
 & -\delta_{\emptyset} + 2\delta_{\{a\}} + \delta_{\{b\}} + \delta_{\{c\}} - 2\delta_{\{a,b\}} - \delta_{\{a,c\}} - \delta_{\{a,d\}} - \delta_{\{b,c\}} + \delta_{\{a,b,c\}} + \delta_{\{a,b,d\}} \\
 & = -u_{\langle a,c|\emptyset \rangle} + u_{\langle b,d|a \rangle} + u_{\langle a,c|b \rangle} \\
 & = (\delta_{\{a\}} + \delta_{\{b\}} - \delta_{\{a,b\}} - \delta_{\{a,d\}} - \delta_{\{b,c\}} + \delta_{\{a,b,c,d\}}) \\
 & \quad - (\delta_{\emptyset} - \delta_{\{a\}} - \delta_{\{c\}} + \delta_{\{a,b\}} + \delta_{\{a,c\}} - \delta_{\{a,b,c\}} - \delta_{\{a,b,d\}} + \delta_{\{a,b,c,d\}})
 \end{aligned}$$

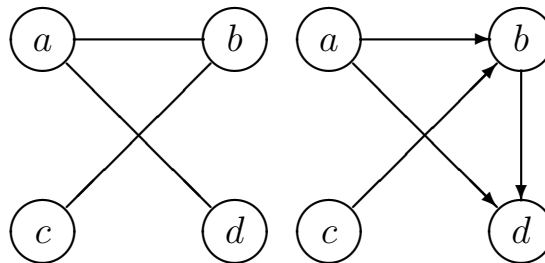

1.16.10.2 Differential imset (199)

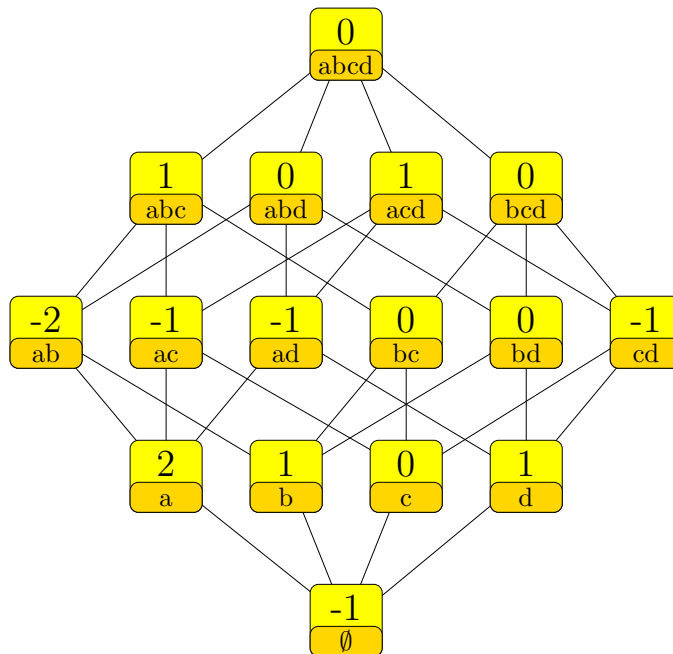

$$\begin{aligned}
 & -\delta_{\emptyset} + 2\delta_{\{a\}} + \delta_{\{b\}} + \delta_{\{d\}} - 2\delta_{\{a,b\}} - \delta_{\{a,c\}} - \delta_{\{a,d\}} - \delta_{\{c,d\}} + \delta_{\{a,b,c\}} + \delta_{\{a,c,d\}} \\
 & = -u_{\langle a,b|\emptyset \rangle} + u_{\langle b,c|a \rangle} + u_{\langle a,c|d \rangle} \\
 & = (\delta_{\{a\}} + \delta_{\{d\}} - \delta_{\{a,b\}} - \delta_{\{a,d\}} - \delta_{\{c,d\}} + \delta_{\{a,b,c,d\}}) \\
 & \quad - (\delta_{\emptyset} - \delta_{\{a\}} - \delta_{\{b\}} + \delta_{\{a,b\}} + \delta_{\{a,c\}} - \delta_{\{a,b,c\}} - \delta_{\{a,c,d\}} + \delta_{\{a,b,c,d\}})
 \end{aligned}$$

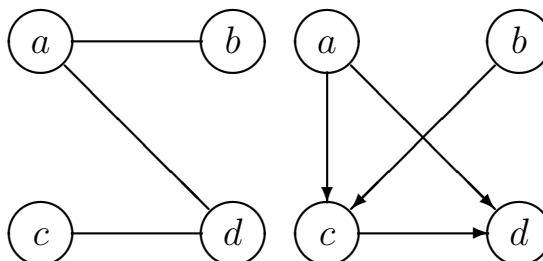



1.16.10.3 Differential imset (200)

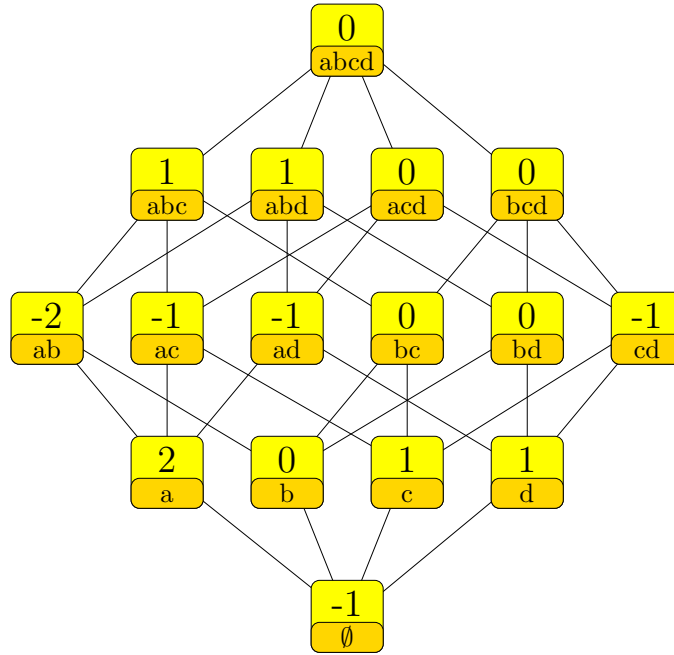

$$\begin{aligned}
 & -\delta_{\emptyset} + 2\delta_{\{a\}} + \delta_{\{c\}} + \delta_{\{d\}} - 2\delta_{\{a,b\}} - \delta_{\{a,c\}} - \delta_{\{a,d\}} - \delta_{\{c,d\}} + \delta_{\{a,b,c\}} + \delta_{\{a,b,d\}} \\
 & = -u_{\langle c,d|\emptyset \rangle} + u_{\langle b,c|a \rangle} + u_{\langle b,d|a \rangle} \\
 & = (\delta_{\{a\}} + \delta_{\{c\}} - \delta_{\{a,b\}} - \delta_{\{a,c\}} - \delta_{\{c,d\}} + \delta_{\{a,b,c,d\}}) \\
 & \quad - (\delta_{\emptyset} - \delta_{\{a\}} - \delta_{\{d\}} + \delta_{\{a,b\}} + \delta_{\{a,d\}} - \delta_{\{a,b,c\}} - \delta_{\{a,b,d\}} + \delta_{\{a,b,c,d\}})
 \end{aligned}$$

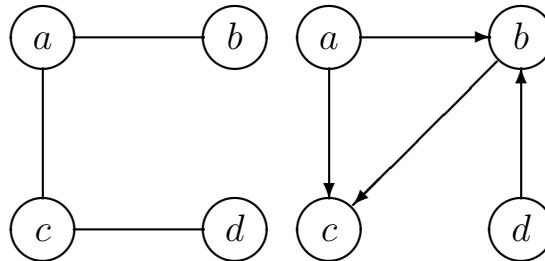

1.16.10.4 Differential imset (201)

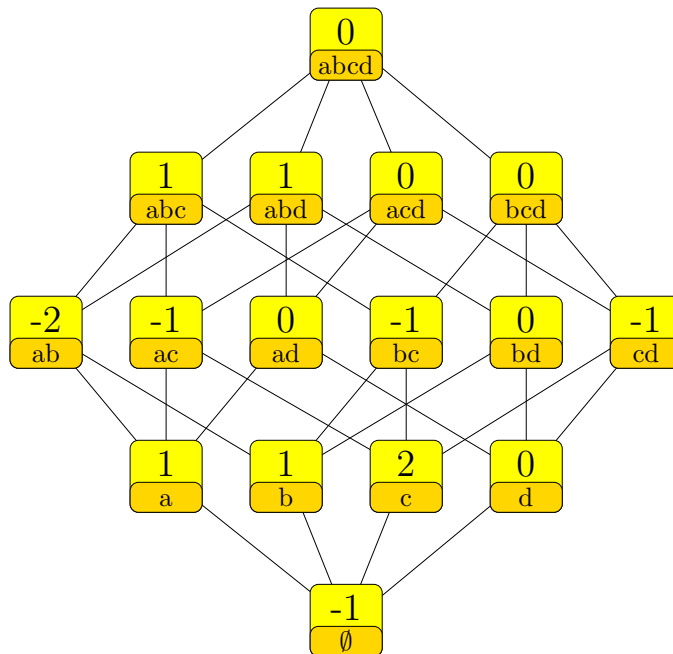

$$\begin{aligned}
 & -\delta_{\emptyset} + \delta_{\{a\}} + \delta_{\{b\}} + 2\delta_{\{c\}} - 2\delta_{\{a,b\}} - \delta_{\{a,c\}} - \delta_{\{b,c\}} - \delta_{\{c,d\}} + \delta_{\{a,b,c\}} + \delta_{\{a,b,d\}} \\
 &= -u_{\langle b,c|\emptyset \rangle} - u_{\langle c,d|ab \rangle} + u_{\langle b,d|ac \rangle} + u_{\langle b,c|a \rangle} + u_{\langle a,d|c \rangle} \\
 &= (\delta_{\{a\}} + \delta_{\{c\}} - \delta_{\{a,b\}} - \delta_{\{a,c\}} - \delta_{\{c,d\}} + \delta_{\{a,b,c,d\}}) \\
 &\quad - (\delta_{\emptyset} - \delta_{\{b\}} - \delta_{\{c\}} + \delta_{\{a,b\}} + \delta_{\{b,c\}} - \delta_{\{a,b,c\}} - \delta_{\{a,b,d\}} + \delta_{\{a,b,c,d\}})
 \end{aligned}$$

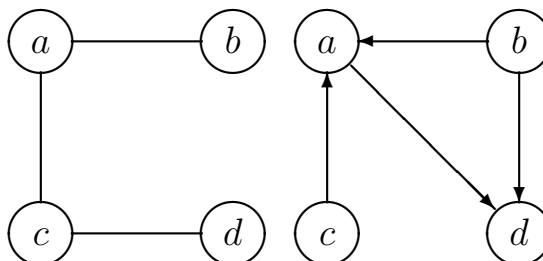

1.16.10.5 Differential imset (202)

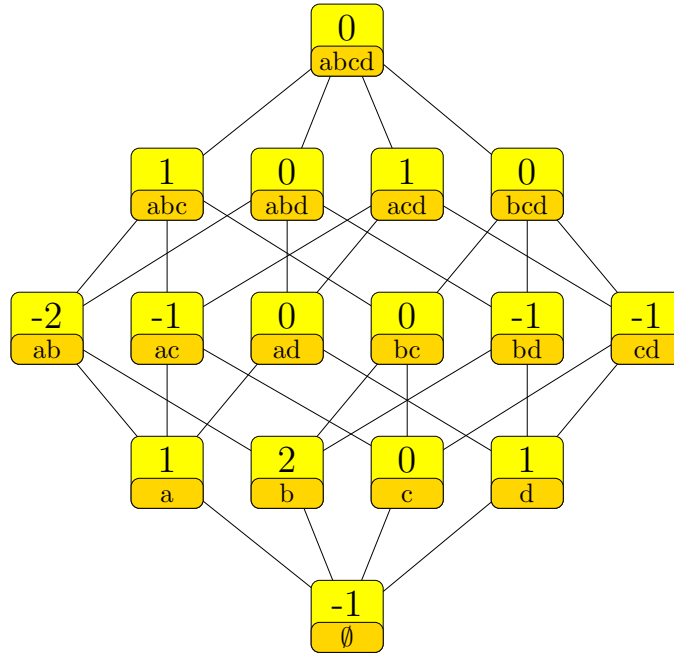

$$\begin{aligned}
 & -\delta_{\emptyset} + \delta_{\{a\}} + 2\delta_{\{b\}} + \delta_{\{d\}} - 2\delta_{\{a,b\}} - \delta_{\{a,c\}} - \delta_{\{b,d\}} - \delta_{\{c,d\}} + \delta_{\{a,b,c\}} + \delta_{\{a,c,d\}} \\
 & = -u_{\langle a,b|\emptyset \rangle} - u_{\langle b,d|ac \rangle} + u_{\langle a,d|bc \rangle} + u_{\langle a,c|b \rangle} + u_{\langle b,c|d \rangle} \\
 & = (\delta_{\{b\}} + \delta_{\{d\}} - \delta_{\{a,b\}} - \delta_{\{b,d\}} - \delta_{\{c,d\}} + \delta_{\{a,b,c,d\}}) \\
 & \quad - (\delta_{\emptyset} - \delta_{\{a\}} - \delta_{\{b\}} + \delta_{\{a,b\}} + \delta_{\{a,c\}} - \delta_{\{a,b,c\}} - \delta_{\{a,c,d\}} + \delta_{\{a,b,c,d\}})
 \end{aligned}$$

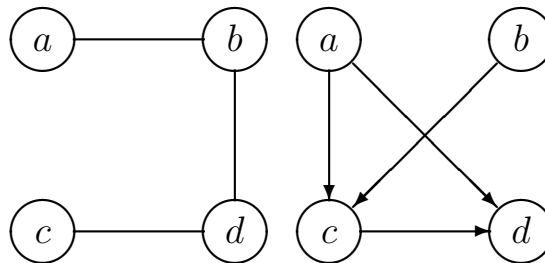

1.16.10.6 Differential imset (203)

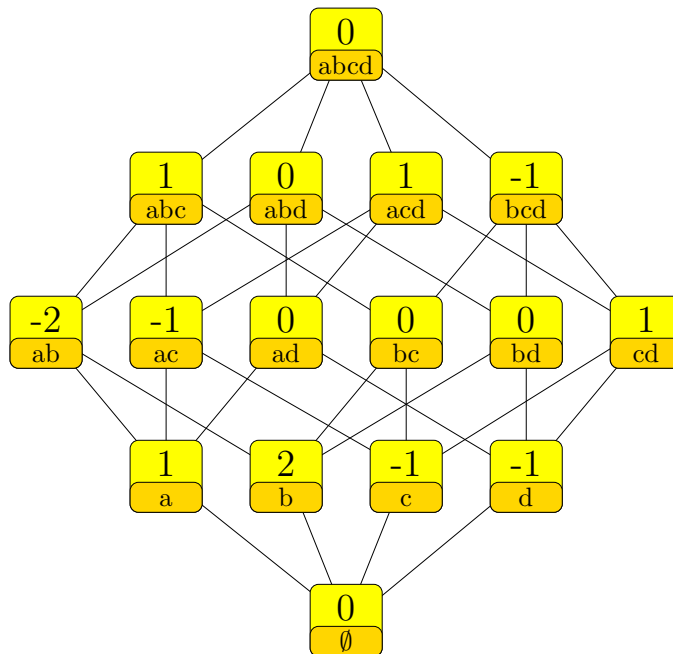

$$\begin{aligned}
 & \delta_{\{a\}} + 2\delta_{\{b\}} - \delta_{\{c\}} - \delta_{\{d\}} - 2\delta_{\{a,b\}} - \delta_{\{a,c\}} + \delta_{\{c,d\}} + \delta_{\{a,b,c\}} + \delta_{\{a,c,d\}} - \delta_{\{b,c,d\}} \\
 &= -u_{\langle a,b|\emptyset \rangle} + u_{\langle c,d|\emptyset \rangle} - u_{\langle b,d|ac \rangle} + u_{\langle a,d|bc \rangle} + u_{\langle a,c|b \rangle} \\
 &= (\delta_{\emptyset} + \delta_{\{b\}} - \delta_{\{c\}} - \delta_{\{d\}} - \delta_{\{a,b\}} + \delta_{\{c,d\}} - \delta_{\{b,c,d\}} + \delta_{\{a,b,c,d\}}) \\
 &\quad - (\delta_{\emptyset} - \delta_{\{a\}} - \delta_{\{b\}} + \delta_{\{a,b\}} + \delta_{\{a,c\}} - \delta_{\{a,b,c\}} - \delta_{\{a,c,d\}} + \delta_{\{a,b,c,d\}})
 \end{aligned}$$

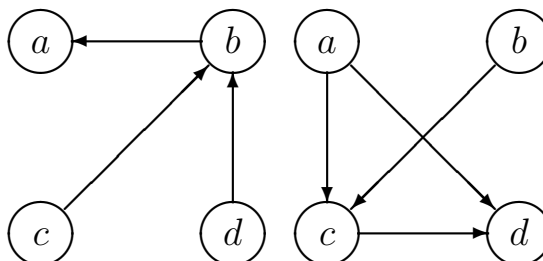

1.16.10.7 Differential imset (204)

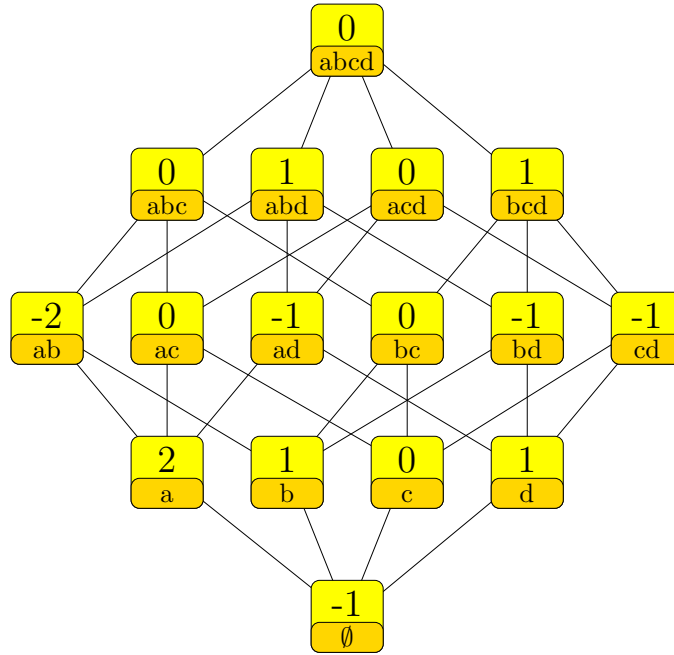

$$\begin{aligned}
 & -\delta_{\emptyset} + 2\delta_{\{a\}} + \delta_{\{b\}} + \delta_{\{d\}} - 2\delta_{\{a,b\}} - \delta_{\{a,d\}} - \delta_{\{b,d\}} - \delta_{\{c,d\}} + \delta_{\{a,b,d\}} + \delta_{\{b,c,d\}} \\
 & = -u_{\langle a,b|\emptyset \rangle} + u_{\langle b,d|a \rangle} + u_{\langle b,c|d \rangle} \\
 & = (\delta_{\{a\}} + \delta_{\{d\}} - \delta_{\{a,b\}} - \delta_{\{a,d\}} - \delta_{\{c,d\}} + \delta_{\{a,b,c,d\}}) \\
 & \quad - (\delta_{\emptyset} - \delta_{\{a\}} - \delta_{\{b\}} + \delta_{\{a,b\}} + \delta_{\{b,d\}} - \delta_{\{a,b,d\}} - \delta_{\{b,c,d\}} + \delta_{\{a,b,c,d\}})
 \end{aligned}$$

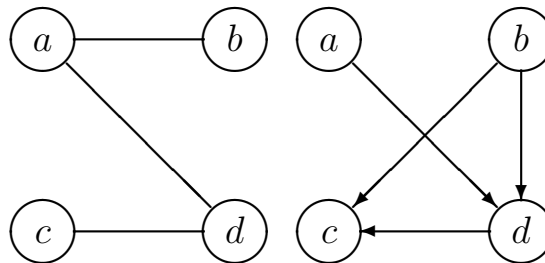

1.16.10.8 Differential imset (205)

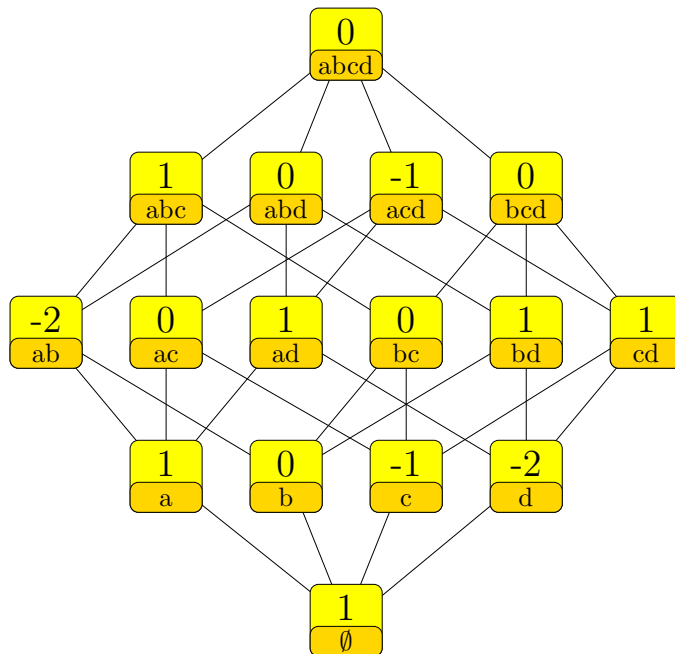

$$\begin{aligned}
 & \delta_{\emptyset} + \delta_{\{a\}} - \delta_{\{c\}} - 2\delta_{\{d\}} - 2\delta_{\{a,b\}} + \delta_{\{a,d\}} + \delta_{\{b,d\}} + \delta_{\{c,d\}} + \delta_{\{a,b,c\}} - \delta_{\{a,c,d\}} \\
 &= u_{\langle c,d|\emptyset \rangle} - u_{\langle c,d|ab \rangle} + u_{\langle b,d|ac \rangle} + u_{\langle b,c|a \rangle} - u_{\langle a,b|d \rangle} \\
 &= (\delta_{\emptyset} + \delta_{\{a\}} - \delta_{\{c\}} - \delta_{\{d\}} - \delta_{\{a,b\}} + \delta_{\{c,d\}} - \delta_{\{a,c,d\}} + \delta_{\{a,b,c,d\}}) \\
 &\quad - (\delta_{\{d\}} + \delta_{\{a,b\}} - \delta_{\{a,d\}} - \delta_{\{b,d\}} - \delta_{\{a,b,c\}} + \delta_{\{a,b,c,d\}})
 \end{aligned}$$

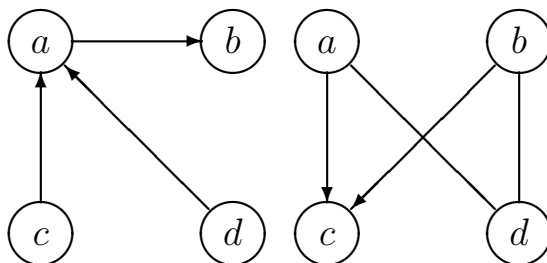

1.16.10.9 Differential imset (206)

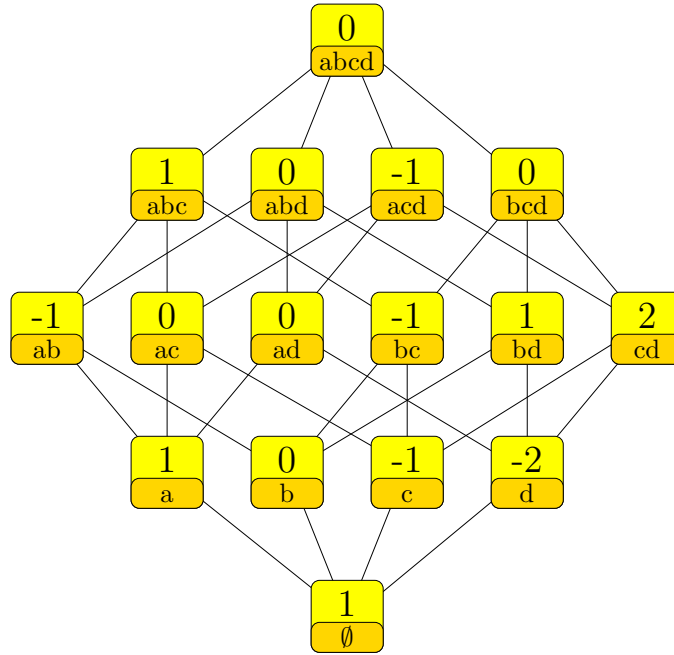

$$\begin{aligned}
 & \delta_{\emptyset} + \delta_{\{a\}} - \delta_{\{c\}} - 2\delta_{\{d\}} - \delta_{\{a,b\}} - \delta_{\{b,c\}} + \delta_{\{b,d\}} + 2\delta_{\{c,d\}} + \delta_{\{a,b,c\}} - \delta_{\{a,c,d\}} \\
 &= u_{\langle c,d|\emptyset \rangle} + u_{\langle b,d|ac \rangle} - u_{\langle a,d|bc \rangle} + u_{\langle b,c|a \rangle} - u_{\langle b,c|d \rangle} \\
 &= (\delta_{\emptyset} + \delta_{\{a\}} - \delta_{\{c\}} - \delta_{\{d\}} - \delta_{\{a,b\}} + \delta_{\{c,d\}} - \delta_{\{a,c,d\}} + \delta_{\{a,b,c,d\}}) \\
 &\quad - (\delta_{\{d\}} + \delta_{\{b,c\}} - \delta_{\{b,d\}} - \delta_{\{c,d\}} - \delta_{\{a,b,c\}} + \delta_{\{a,b,c,d\}})
 \end{aligned}$$

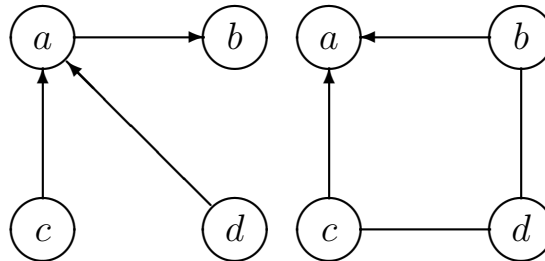

1.16.10.10 Differential imset (207)

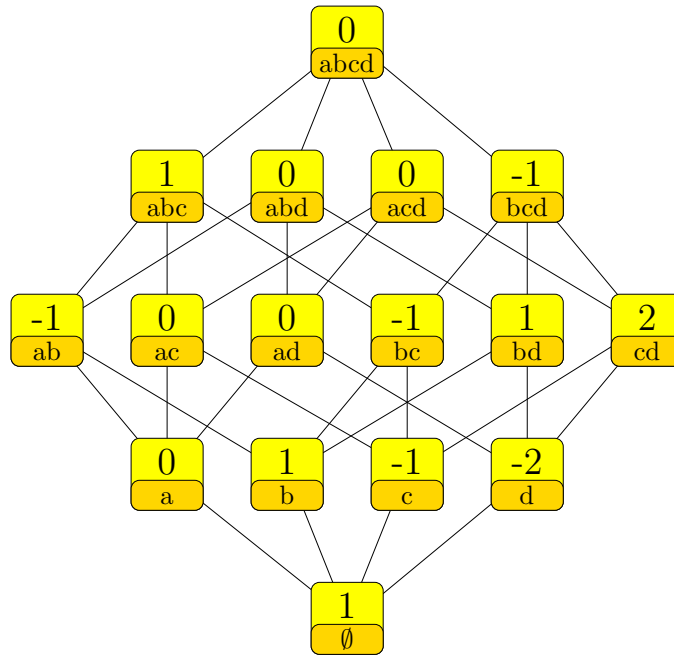

$$\begin{aligned}
 & \delta_{\emptyset} + \delta_{\{b\}} - \delta_{\{c\}} - 2\delta_{\{d\}} - \delta_{\{a,b\}} - \delta_{\{b,c\}} + \delta_{\{b,d\}} + 2\delta_{\{c,d\}} + \delta_{\{a,b,c\}} - \delta_{\{b,c,d\}} \\
 &= u_{\langle c,d|\emptyset \rangle} + u_{\langle a,c|b \rangle} - u_{\langle b,c|d \rangle} \\
 &= (\delta_{\emptyset} + \delta_{\{b\}} - \delta_{\{c\}} - \delta_{\{d\}} - \delta_{\{a,b\}} + \delta_{\{c,d\}} - \delta_{\{b,c,d\}} + \delta_{\{a,b,c,d\}}) \\
 &\quad - (\delta_{\{d\}} + \delta_{\{b,c\}} - \delta_{\{b,d\}} - \delta_{\{c,d\}} - \delta_{\{a,b,c\}} + \delta_{\{a,b,c,d\}})
 \end{aligned}$$

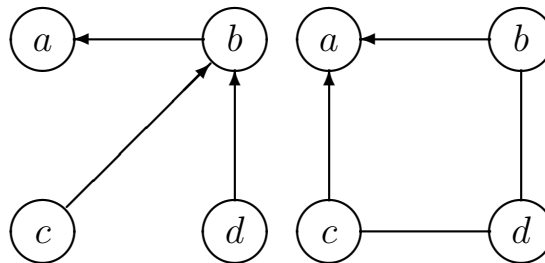



1.16.10.11 Differential imset (208)

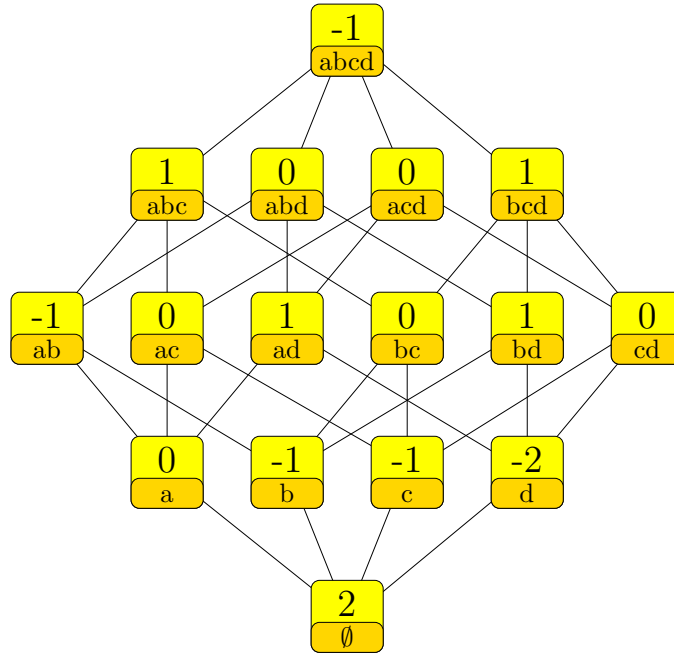

$$\begin{aligned}
 &+2\delta_\emptyset - \delta_{\{b\}} - \delta_{\{c\}} - 2\delta_{\{d\}} - \delta_{\{a,b\}} + \delta_{\{a,d\}} + \delta_{\{b,d\}} + \delta_{\{a,b,c\}} + \delta_{\{b,c,d\}} - \delta_{\{a,b,c,d\}} \\
 &= u_{\langle b,c|\emptyset \rangle} + u_{\langle b,d|\emptyset \rangle} - u_{\langle c,d|ab \rangle} - u_{\langle a,b|d \rangle} + u_{\langle c,d|b \rangle} \\
 &= (+2\delta_\emptyset - \delta_{\{b\}} - \delta_{\{c\}} - \delta_{\{d\}} + \delta_{\{b,c,d\}}) \\
 &\quad - (\delta_{\{d\}} + \delta_{\{a,b\}} - \delta_{\{a,d\}} - \delta_{\{b,d\}} - \delta_{\{a,b,c\}} + \delta_{\{a,b,c,d\}})
 \end{aligned}$$

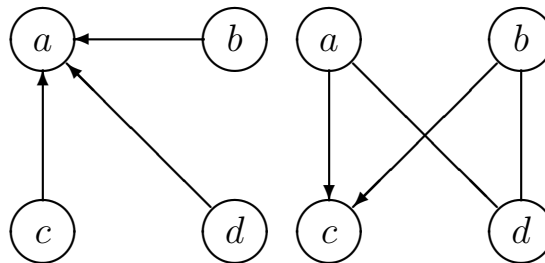

1.16.10.12 Differential imset (209)

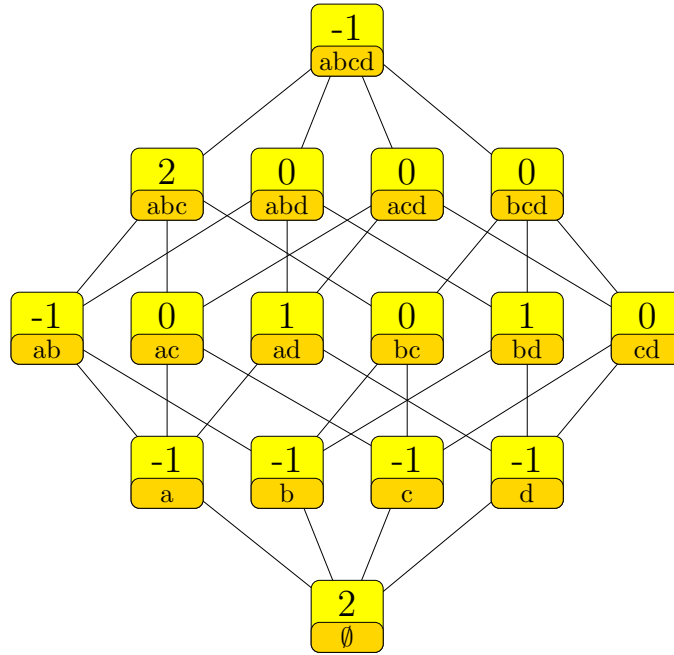

$$\begin{aligned}
 &+2\delta_\emptyset - \delta_{\{a\}} - \delta_{\{b\}} - \delta_{\{c\}} - \delta_{\{d\}} - \delta_{\{a,b\}} + \delta_{\{a,d\}} + \delta_{\{b,d\}} + 2\delta_{\{a,b,c\}} - \delta_{\{a,b,c,d\}} \\
 &= u_{\langle a,b|\emptyset \rangle} + u_{\langle a,c|\emptyset \rangle} - u_{\langle c,d|ab \rangle} + u_{\langle b,c|a \rangle} - u_{\langle a,b|d \rangle} \\
 &= (+2\delta_\emptyset - \delta_{\{a\}} - \delta_{\{b\}} - \delta_{\{c\}} + \delta_{\{a,b,c\}}) \\
 &\quad - (\delta_{\{d\}} + \delta_{\{a,b\}} - \delta_{\{a,d\}} - \delta_{\{b,d\}} - \delta_{\{a,b,c\}} + \delta_{\{a,b,c,d\}})
 \end{aligned}$$

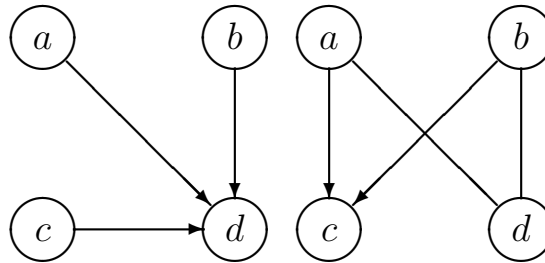

1.16.10.13 Differential imset (210)

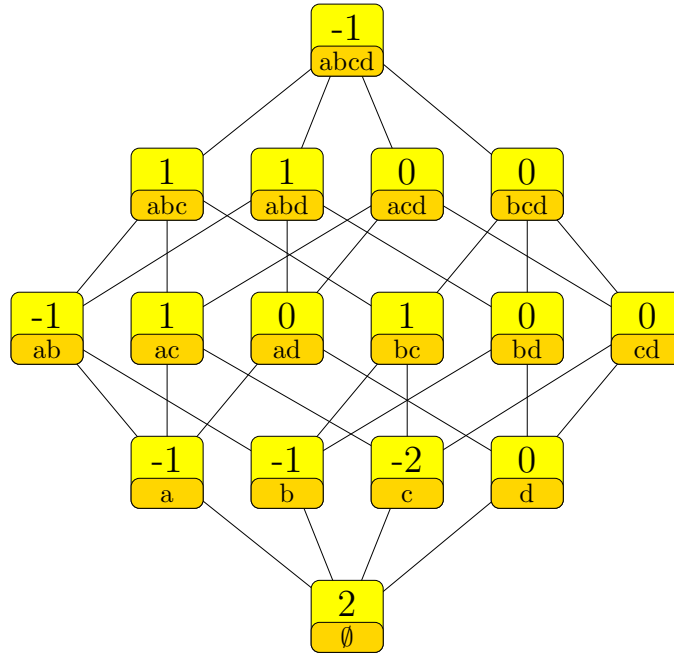

$$\begin{aligned}
 &+2\delta_\emptyset - \delta_{\{a\}} - \delta_{\{b\}} - 2\delta_{\{c\}} - \delta_{\{a,b\}} + \delta_{\{a,c\}} + \delta_{\{b,c\}} + \delta_{\{a,b,c\}} + \delta_{\{a,b,d\}} - \delta_{\{a,b,c,d\}} \\
 &= u_{\langle a,c|\emptyset\rangle} + u_{\langle b,c|\emptyset\rangle} - u_{\langle c,d|ab\rangle} \\
 &= (+2\delta_\emptyset - \delta_{\{a\}} - \delta_{\{b\}} - \delta_{\{c\}} + \delta_{\{a,b,c\}}) \\
 &\quad - (\delta_{\{c\}} + \delta_{\{a,b\}} - \delta_{\{a,c\}} - \delta_{\{b,c\}} - \delta_{\{a,b,d\}} + \delta_{\{a,b,c,d\}})
 \end{aligned}$$

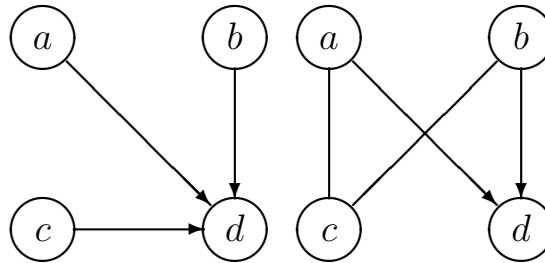

1.16.10.14 Differential imset (211)

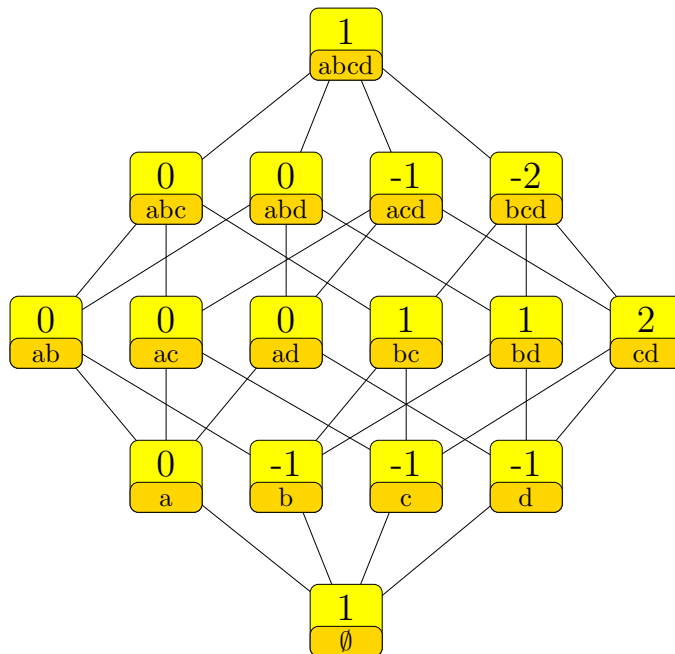

$$\begin{aligned}
 & \delta_\emptyset - \delta_{\{b\}} - \delta_{\{c\}} - \delta_{\{d\}} + \delta_{\{b,c\}} + \delta_{\{b,d\}} + 2\delta_{\{c,d\}} - \delta_{\{a,c,d\}} - 2\delta_{\{b,c,d\}} + \delta_{\{a,b,c,d\}} \\
 &= u_{\langle c,d|\emptyset\rangle} + u_{\langle a,b|cd\rangle} - u_{\langle c,d|b\rangle} \\
 &= (\delta_\emptyset - \delta_{\{c\}} - \delta_{\{d\}} + 2\delta_{\{c,d\}} - \delta_{\{a,c,d\}} - \delta_{\{b,c,d\}} + \delta_{\{a,b,c,d\}}) \\
 &\quad - (\delta_{\{b\}} - \delta_{\{b,c\}} - \delta_{\{b,d\}} + \delta_{\{b,c,d\}})
 \end{aligned}$$

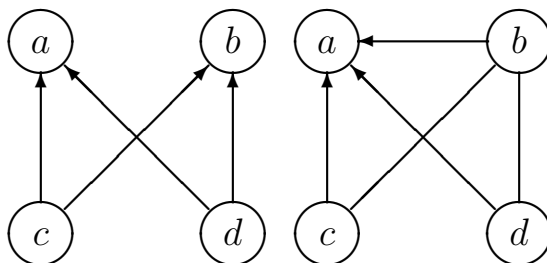

1.16.10.15 Differential imset (212)

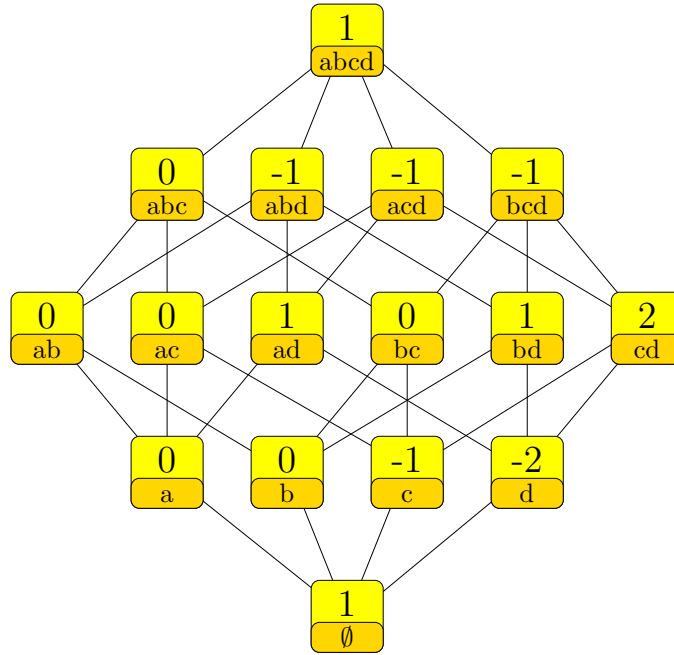

$$\begin{aligned}
 & \delta_\emptyset - \delta_{\{c\}} - 2\delta_{\{d\}} + \delta_{\{a,d\}} + \delta_{\{b,d\}} + 2\delta_{\{c,d\}} - \delta_{\{a,b,d\}} - \delta_{\{a,c,d\}} - \delta_{\{b,c,d\}} + \delta_{\{a,b,c,d\}} \\
 &= u_{\langle c,d|\emptyset \rangle} + u_{\langle a,b|cd \rangle} - u_{\langle a,b|d \rangle} \\
 &= (\delta_\emptyset - \delta_{\{c\}} - \delta_{\{d\}} + \delta_{\{b,d\}} + \delta_{\{c,d\}} - \delta_{\{a,b,d\}} - \delta_{\{b,c,d\}} + \delta_{\{a,b,c,d\}}) \\
 &\quad - (\delta_{\{d\}} - \delta_{\{a,d\}} - \delta_{\{c,d\}} + \delta_{\{a,c,d\}}) \\
 &= (\delta_\emptyset - \delta_{\{c\}} - \delta_{\{d\}} + 2\delta_{\{c,d\}} - \delta_{\{a,c,d\}} - \delta_{\{b,c,d\}} + \delta_{\{a,b,c,d\}}) \\
 &\quad - (\delta_{\{d\}} - \delta_{\{a,d\}} - \delta_{\{b,d\}} + \delta_{\{a,b,d\}})
 \end{aligned}$$

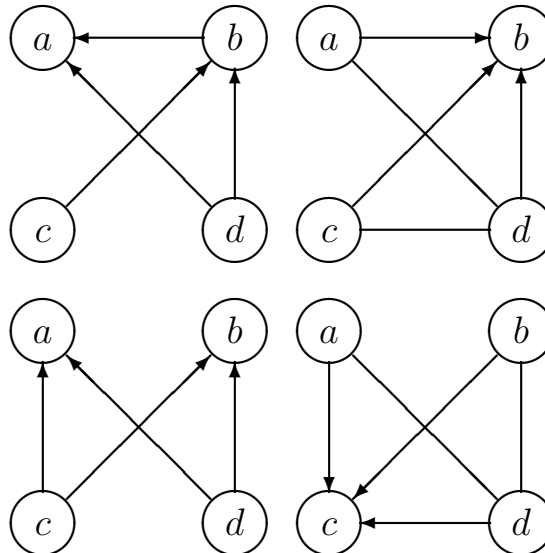

1.16.10.16 Differential imset (213)

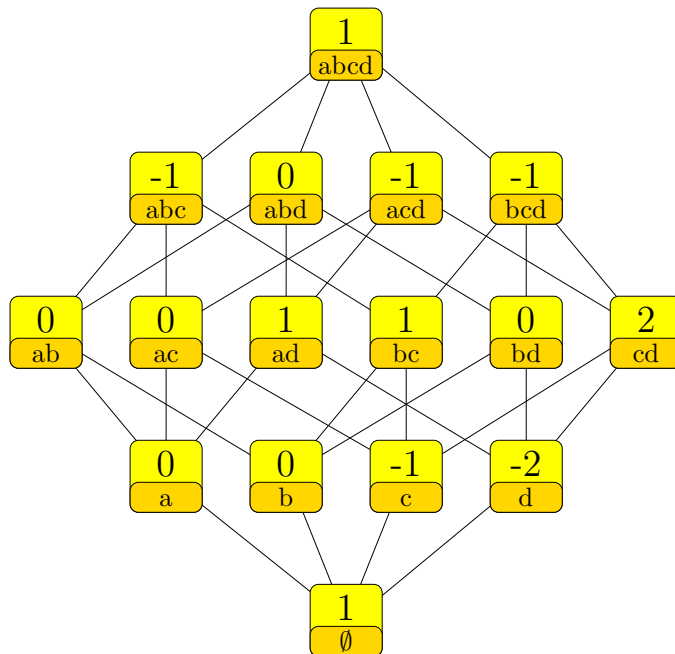

$$\begin{aligned}
 & \delta_{\emptyset} - \delta_{\{c\}} - 2\delta_{\{d\}} + \delta_{\{a,d\}} + \delta_{\{b,c\}} + 2\delta_{\{c,d\}} - \delta_{\{a,b,c\}} - \delta_{\{a,c,d\}} - \delta_{\{b,c,d\}} + \delta_{\{a,b,c,d\}} \\
 &= u_{\langle c,d|\emptyset \rangle} + u_{\langle a,d|bc \rangle} - u_{\langle a,c|d \rangle} \\
 &= (\delta_{\emptyset} - \delta_{\{c\}} - \delta_{\{d\}} + \delta_{\{b,c\}} + \delta_{\{c,d\}} - \delta_{\{a,b,c\}} - \delta_{\{b,c,d\}} + \delta_{\{a,b,c,d\}}) \\
 &\quad - (\delta_{\{d\}} - \delta_{\{a,d\}} - \delta_{\{c,d\}} + \delta_{\{a,c,d\}})
 \end{aligned}$$

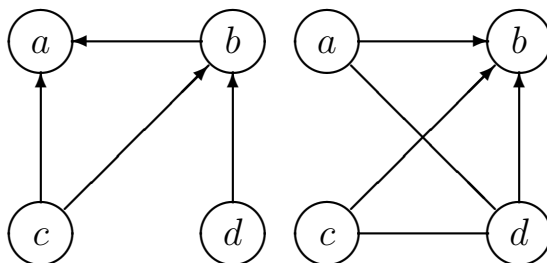

1.16.10.17 Differential imset (214)

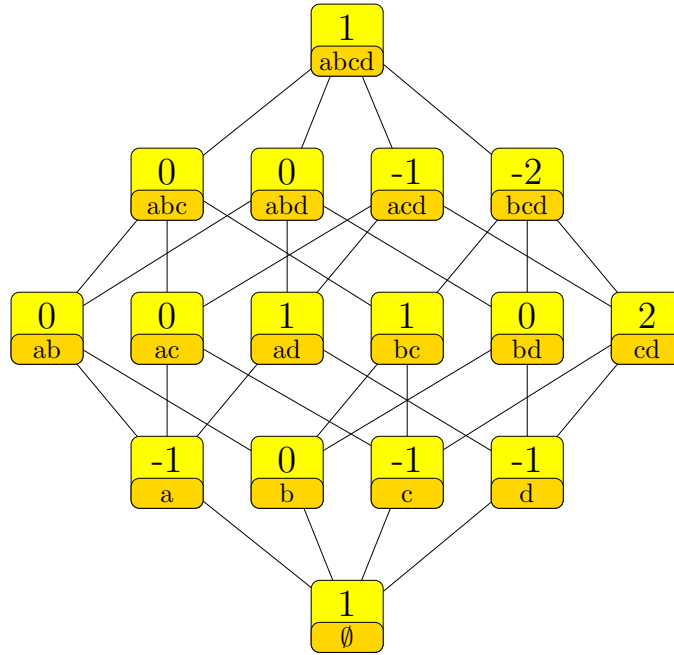

$$\begin{aligned}
 & \delta_\emptyset - \delta_{\{a\}} - \delta_{\{c\}} - \delta_{\{d\}} + \delta_{\{a,d\}} + \delta_{\{b,c\}} + 2\delta_{\{c,d\}} - \delta_{\{a,c,d\}} - 2\delta_{\{b,c,d\}} + \delta_{\{a,b,c,d\}} \\
 &= u_{\langle a,d|\emptyset \rangle} + u_{\langle a,b|cd \rangle} - u_{\langle b,d|c \rangle} \\
 &= (\delta_\emptyset - \delta_{\{a\}} - \delta_{\{d\}} + \delta_{\{a,d\}} + \delta_{\{c,d\}} - \delta_{\{a,c,d\}} - \delta_{\{b,c,d\}} + \delta_{\{a,b,c,d\}}) \\
 &\quad - (\delta_{\{c\}} - \delta_{\{b,c\}} - \delta_{\{c,d\}} + \delta_{\{b,c,d\}})
 \end{aligned}$$

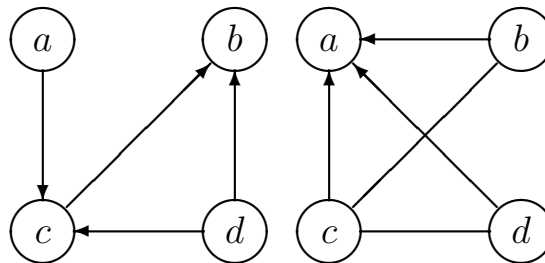

1.16.10.18 Differential imset (215)

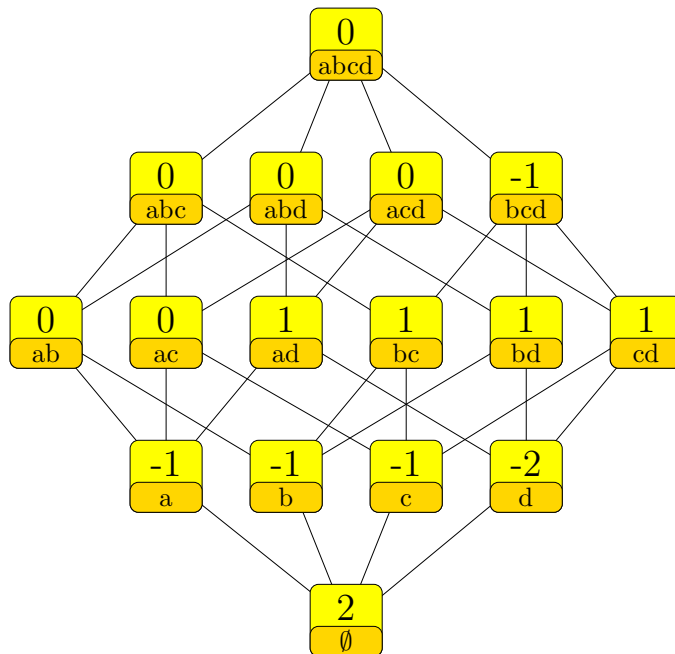

$$\begin{aligned}
 &+2\delta_\emptyset - \delta_{\{a\}} - \delta_{\{b\}} - \delta_{\{c\}} - 2\delta_{\{d\}} + \delta_{\{a,d\}} + \delta_{\{b,c\}} + \delta_{\{b,d\}} + \delta_{\{c,d\}} - \delta_{\{b,c,d\}} \\
 &= u_{\langle a,d|\emptyset \rangle} + u_{\langle b,d|\emptyset \rangle} - u_{\langle b,d|c \rangle} \\
 &= (+2\delta_\emptyset - \delta_{\{a\}} - \delta_{\{b\}} - \delta_{\{c\}} + \delta_{\{b,c\}} - \delta_{\{b,c,d\}} + \delta_{\{a,b,c,d\}}) \\
 &\quad - (+2\delta_{\{d\}} - \delta_{\{a,d\}} - \delta_{\{b,d\}} - \delta_{\{c,d\}} + \delta_{\{a,b,c,d\}})
 \end{aligned}$$

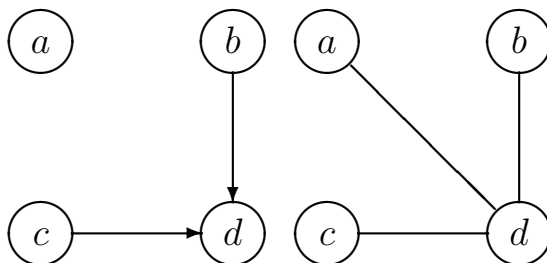



1.16.10.19 Differential imset (216)

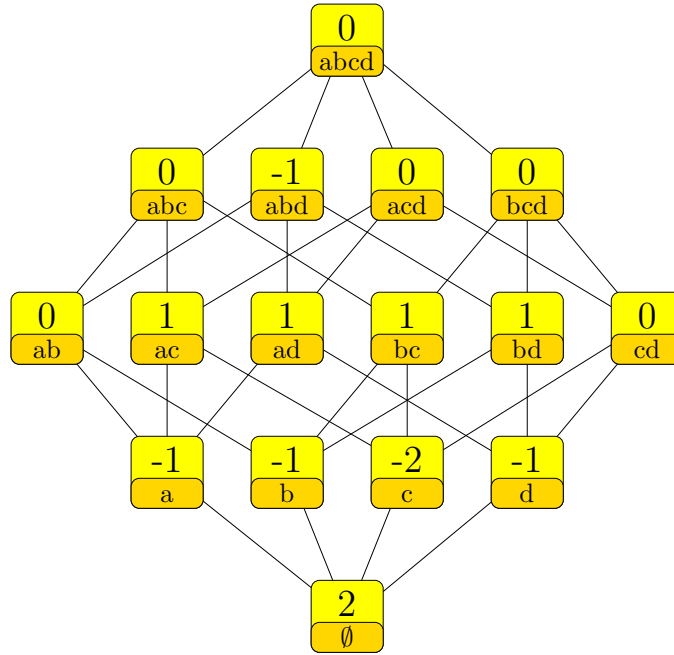

$$\begin{aligned}
 &+2\delta_\emptyset - \delta_{\{a\}} - \delta_{\{b\}} - 2\delta_{\{c\}} - \delta_{\{d\}} + \delta_{\{a,c\}} + \delta_{\{a,d\}} + \delta_{\{b,c\}} + \delta_{\{b,d\}} - \delta_{\{a,b,d\}} \\
 &= u_{\langle a,c|\emptyset \rangle} + u_{\langle b,c|\emptyset \rangle} - u_{\langle a,b|d \rangle} \\
 &= (+2\delta_\emptyset - \delta_{\{a\}} - \delta_{\{c\}} - \delta_{\{d\}} + \delta_{\{a,d\}} - \delta_{\{a,b,d\}} + \delta_{\{a,b,c,d\}}) \\
 &\quad - (\delta_{\{b\}} + \delta_{\{c\}} - \delta_{\{a,c\}} - \delta_{\{b,c\}} - \delta_{\{b,d\}} + \delta_{\{a,b,c,d\}})
 \end{aligned}$$

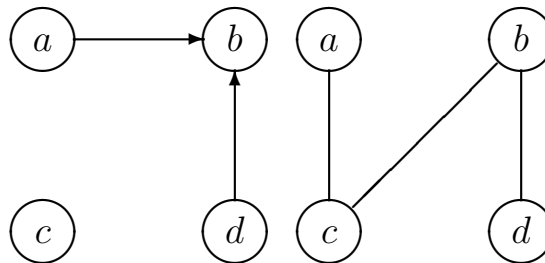

### 1.18 Squared Euclidean length 18

#### 1.18.9 Number of nonzero values 9

##### 1.18.9.1 Differential imset (217)

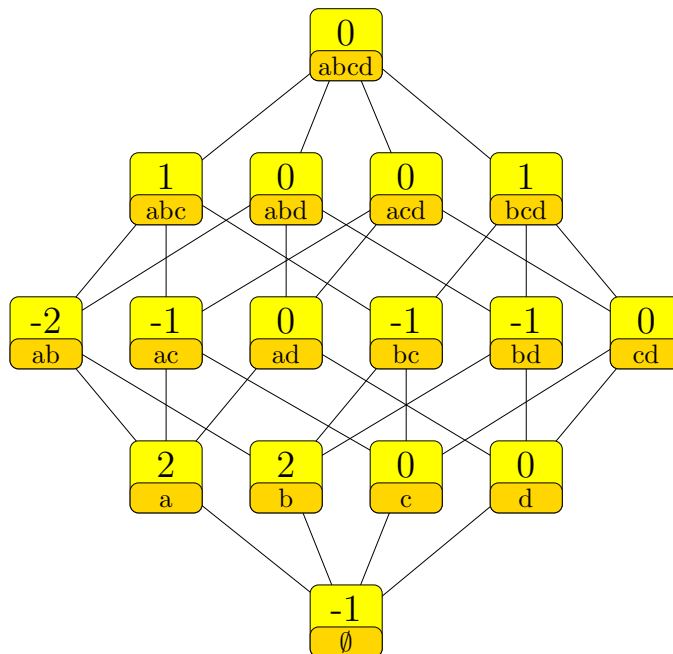

$$\begin{aligned}
 & -\delta_\emptyset + 2\delta_{\{a\}} + 2\delta_{\{b\}} - 2\delta_{\{a,b\}} - \delta_{\{a,c\}} - \delta_{\{b,c\}} - \delta_{\{b,d\}} + \delta_{\{a,b,c\}} + \delta_{\{b,c,d\}} \\
 &= -u_{\langle a,b|\emptyset \rangle} + u_{\langle b,c|a \rangle} + u_{\langle c,d|b \rangle} \\
 &= (\delta_{\{a\}} + \delta_{\{b\}} - \delta_{\{a,b\}} - \delta_{\{a,c\}} - \delta_{\{b,d\}} + \delta_{\{a,b,c,d\}}) \\
 &\quad - (\delta_\emptyset - \delta_{\{a\}} - \delta_{\{b\}} + \delta_{\{a,b\}} + \delta_{\{b,c\}} - \delta_{\{a,b,c\}} - \delta_{\{b,c,d\}} + \delta_{\{a,b,c,d\}})
 \end{aligned}$$

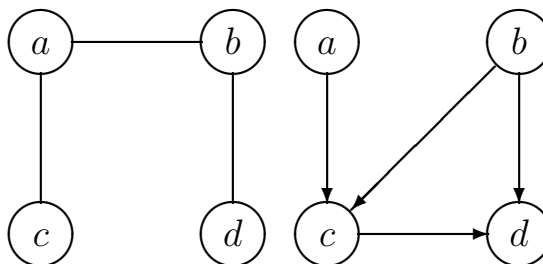

1.18.9.2 Differential imset (218)

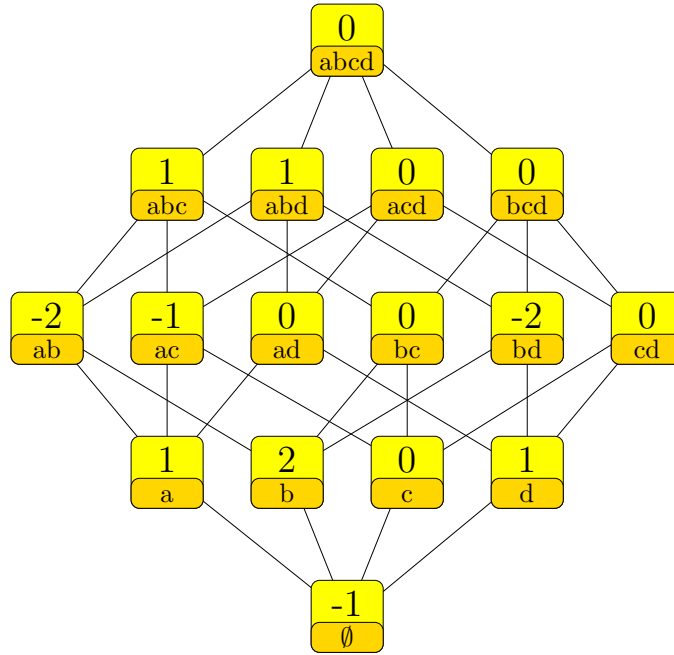

$$\begin{aligned}
 & -\delta_{\emptyset} + \delta_{\{a\}} + 2\delta_{\{b\}} + \delta_{\{d\}} - 2\delta_{\{a,b\}} - \delta_{\{a,c\}} - 2\delta_{\{b,d\}} + \delta_{\{a,b,c\}} + \delta_{\{a,b,d\}} \\
 & = -u_{\langle b,d|\emptyset \rangle} + u_{\langle b,c|a \rangle} + u_{\langle a,d|b \rangle} \\
 & = (\delta_{\{a\}} + \delta_{\{b\}} - \delta_{\{a,b\}} - \delta_{\{a,c\}} - \delta_{\{b,d\}} + \delta_{\{a,b,c,d\}}) \\
 & \quad - (\delta_{\emptyset} - \delta_{\{b\}} - \delta_{\{d\}} + \delta_{\{a,b\}} + \delta_{\{b,d\}} - \delta_{\{a,b,c\}} - \delta_{\{a,b,d\}} + \delta_{\{a,b,c,d\}})
 \end{aligned}$$

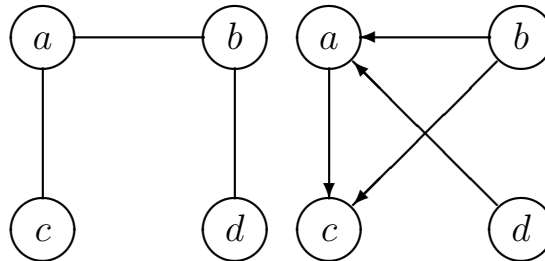

1.18.9.3 Differential imset (219)

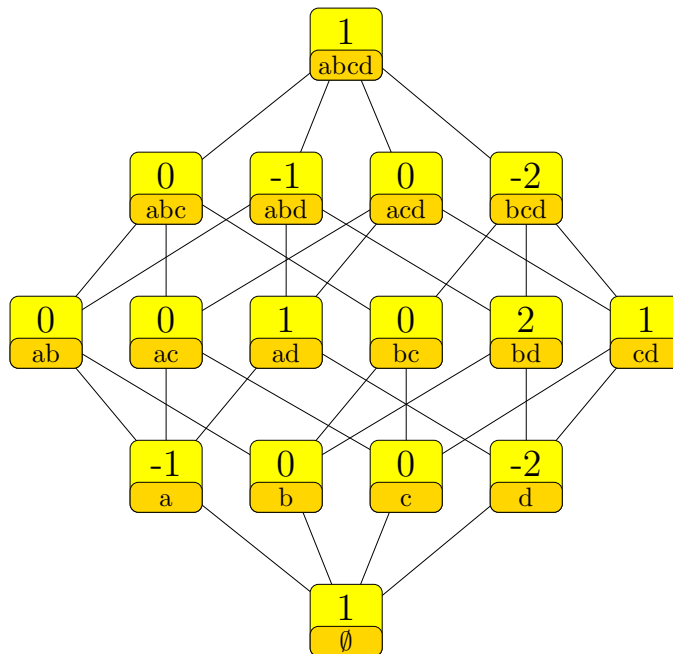

$$\begin{aligned}
 & \delta_\emptyset - \delta_{\{a\}} - 2\delta_{\{d\}} + \delta_{\{a,d\}} + 2\delta_{\{b,d\}} + \delta_{\{c,d\}} - \delta_{\{a,b,d\}} - 2\delta_{\{b,c,d\}} + \delta_{\{a,b,c,d\}} \\
 &= u_{\langle a,d|\emptyset \rangle} + u_{\langle a,c|bd \rangle} - u_{\langle b,c|d \rangle} \\
 &= (\delta_\emptyset - \delta_{\{a\}} - \delta_{\{d\}} + \delta_{\{a,d\}} + \delta_{\{b,d\}} - \delta_{\{a,b,d\}} - \delta_{\{b,c,d\}} + \delta_{\{a,b,c,d\}}) \\
 &\quad - (\delta_{\{d\}} - \delta_{\{b,d\}} - \delta_{\{c,d\}} + \delta_{\{b,c,d\}})
 \end{aligned}$$

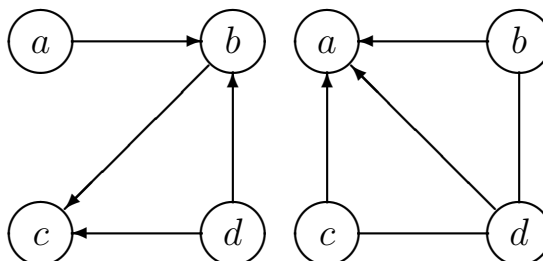

1.18.9.4 Differential imset (220)

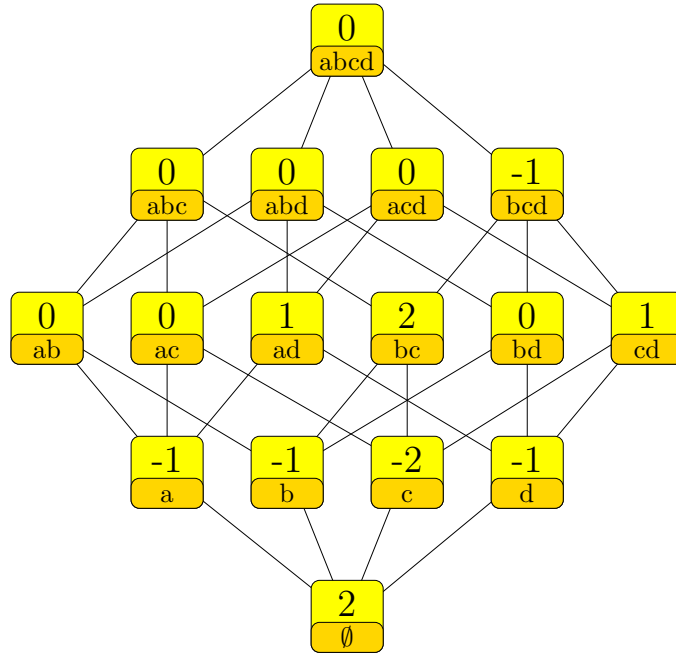

$$\begin{aligned}
 &+2\delta_\emptyset - \delta_{\{a\}} - \delta_{\{b\}} - 2\delta_{\{c\}} - \delta_{\{d\}} + \delta_{\{a,d\}} + 2\delta_{\{b,c\}} + \delta_{\{c,d\}} - \delta_{\{b,c,d\}} \\
 &= u_{\langle a,d|\emptyset \rangle} + u_{\langle b,c|\emptyset \rangle} - u_{\langle b,d|c \rangle} \\
 &= (+2\delta_\emptyset - \delta_{\{a\}} - \delta_{\{b\}} - \delta_{\{c\}} + \delta_{\{b,c\}} - \delta_{\{b,c,d\}} + \delta_{\{a,b,c,d\}}) \\
 &\quad - (\delta_{\{c\}} + \delta_{\{d\}} - \delta_{\{a,d\}} - \delta_{\{b,c\}} - \delta_{\{c,d\}} + \delta_{\{a,b,c,d\}})
 \end{aligned}$$

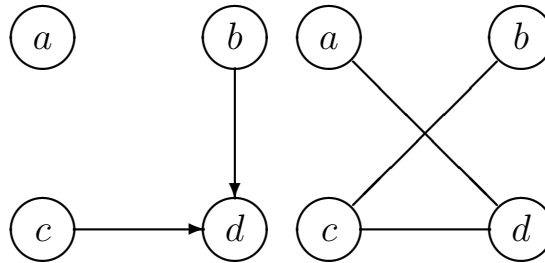

1.18.9.5 Differential imset (221)

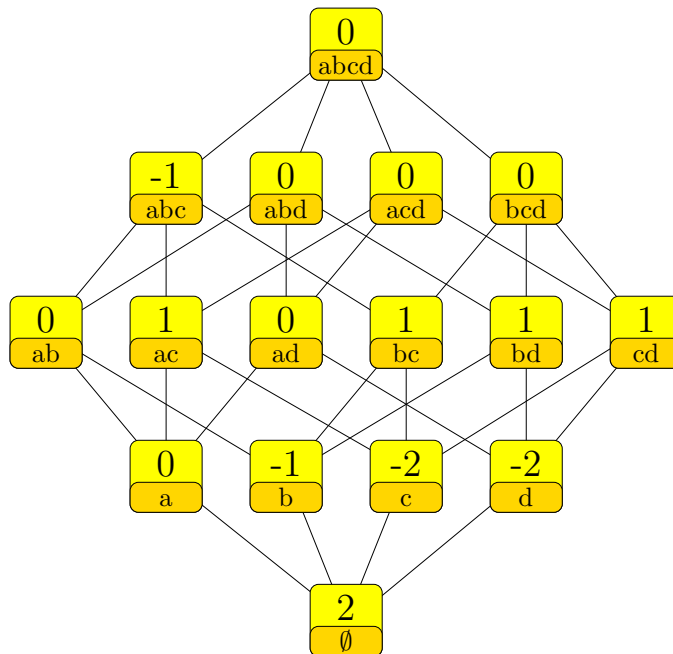

$$\begin{aligned}
 &+2\delta_\emptyset - \delta_{\{b\}} - 2\delta_{\{c\}} - 2\delta_{\{d\}} + \delta_{\{a,c\}} + \delta_{\{b,c\}} + \delta_{\{b,d\}} + \delta_{\{c,d\}} - \delta_{\{a,b,c\}} \\
 &= u_{\langle b,d|\emptyset \rangle} + u_{\langle c,d|\emptyset \rangle} - u_{\langle a,b|c \rangle} \\
 &= (+2\delta_\emptyset - \delta_{\{b\}} - \delta_{\{c\}} - \delta_{\{d\}} + \delta_{\{b,c\}} - \delta_{\{a,b,c\}} + \delta_{\{a,b,c,d\}}) \\
 &\quad - (\delta_{\{c\}} + \delta_{\{d\}} - \delta_{\{a,c\}} - \delta_{\{b,d\}} - \delta_{\{c,d\}} + \delta_{\{a,b,c,d\}})
 \end{aligned}$$

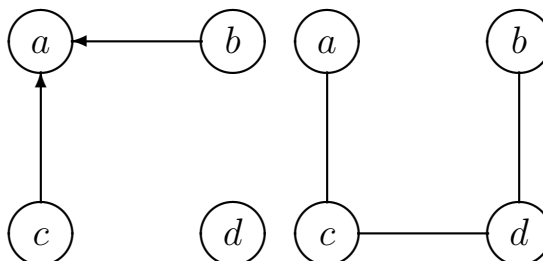

1.18.9.6 Differential imset (222)

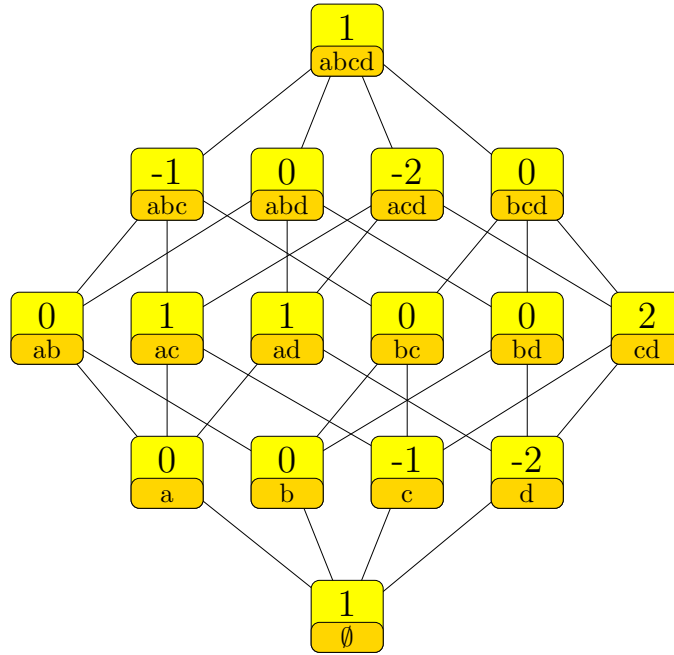

$$\begin{aligned}
 & \delta_\emptyset - \delta_{\{c\}} - 2\delta_{\{d\}} + \delta_{\{a,c\}} + \delta_{\{a,d\}} + 2\delta_{\{c,d\}} - \delta_{\{a,b,c\}} - 2\delta_{\{a,c,d\}} + \delta_{\{a,b,c,d\}} \\
 &= u_{\langle c,d|\emptyset \rangle} + u_{\langle b,d|ac \rangle} - u_{\langle a,c|d \rangle} \\
 &= (\delta_\emptyset - \delta_{\{c\}} - \delta_{\{d\}} + \delta_{\{a,c\}} + \delta_{\{c,d\}} - \delta_{\{a,b,c\}} - \delta_{\{a,c,d\}} + \delta_{\{a,b,c,d\}}) \\
 &\quad - (\delta_{\{d\}} - \delta_{\{a,d\}} - \delta_{\{c,d\}} + \delta_{\{a,c,d\}})
 \end{aligned}$$

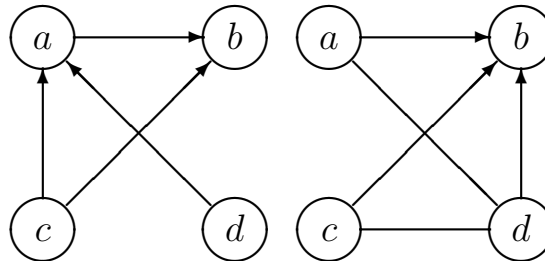

## 1.20 Squared Euclidean length 20

### 1.20.8 Number of nonzero values 8

#### 1.20.8.1 Differential imset (223)

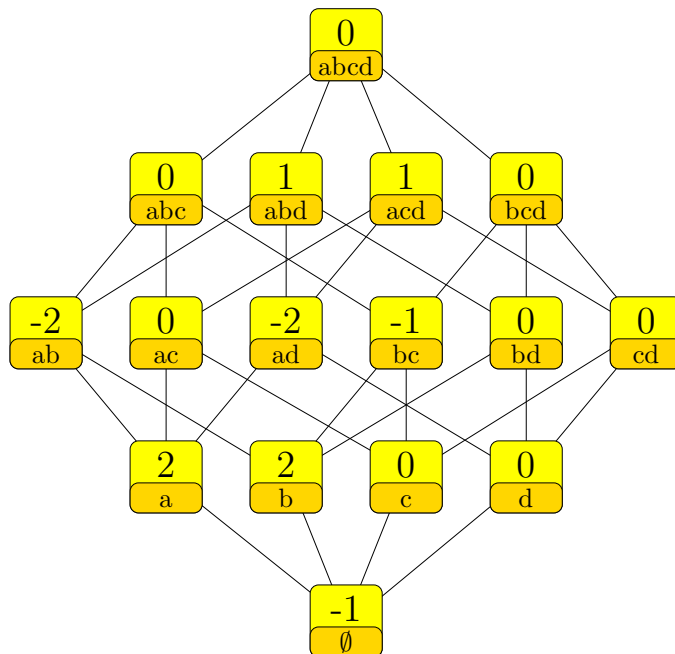

$$\begin{aligned}
 & -\delta_{\emptyset} + 2\delta_{\{a\}} + 2\delta_{\{b\}} - 2\delta_{\{a,b\}} - 2\delta_{\{a,d\}} - \delta_{\{b,c\}} + \delta_{\{a,b,d\}} + \delta_{\{a,c,d\}} \\
 &= -u_{\langle a,b|\emptyset \rangle} + u_{\langle c,d|ab \rangle} - u_{\langle b,c|ad \rangle} + u_{\langle b,d|a \rangle} + u_{\langle a,c|b \rangle} \\
 &= (\delta_{\{a\}} + \delta_{\{b\}} - \delta_{\{a,b\}} - \delta_{\{a,d\}} - \delta_{\{b,c\}} + \delta_{\{a,b,c,d\}}) \\
 &\quad - (\delta_{\emptyset} - \delta_{\{a\}} - \delta_{\{b\}} + \delta_{\{a,b\}} + \delta_{\{a,d\}} - \delta_{\{a,b,d\}} - \delta_{\{a,c,d\}} + \delta_{\{a,b,c,d\}})
 \end{aligned}$$

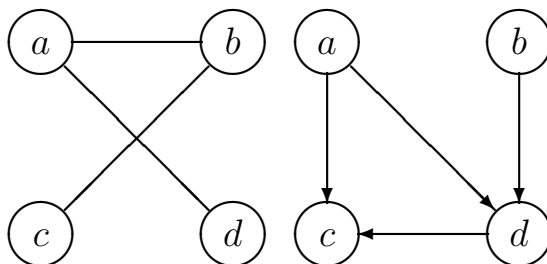



1.20.8.2 Differential imset (224)

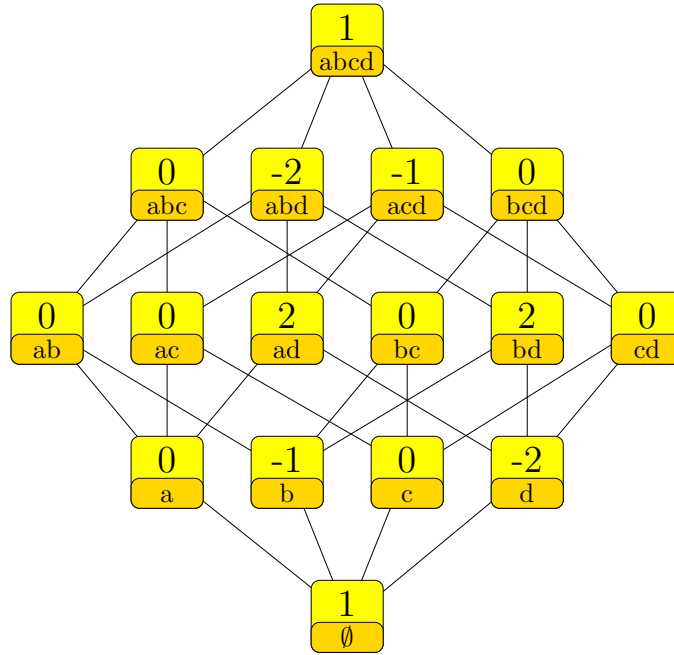

$$\begin{aligned}
 & \delta_\emptyset - \delta_{\{b\}} - 2\delta_{\{d\}} + 2\delta_{\{a,d\}} + 2\delta_{\{b,d\}} - 2\delta_{\{a,b,d\}} - \delta_{\{a,c,d\}} + \delta_{\{a,b,c,d\}} \\
 &= u_{\langle b,d|\emptyset \rangle} + u_{\langle b,c|ad \rangle} - u_{\langle a,b|d \rangle} \\
 &= (\delta_\emptyset - \delta_{\{b\}} - \delta_{\{d\}} + \delta_{\{a,d\}} + \delta_{\{b,d\}} - \delta_{\{a,b,d\}} - \delta_{\{a,c,d\}} + \delta_{\{a,b,c,d\}}) \\
 &\quad - (\delta_{\{d\}} - \delta_{\{a,d\}} - \delta_{\{b,d\}} + \delta_{\{a,b,d\}})
 \end{aligned}$$

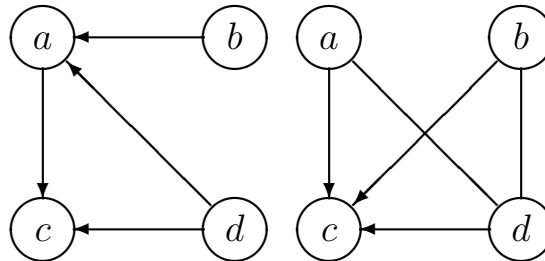

1.20.8.3 Differential imset (225)

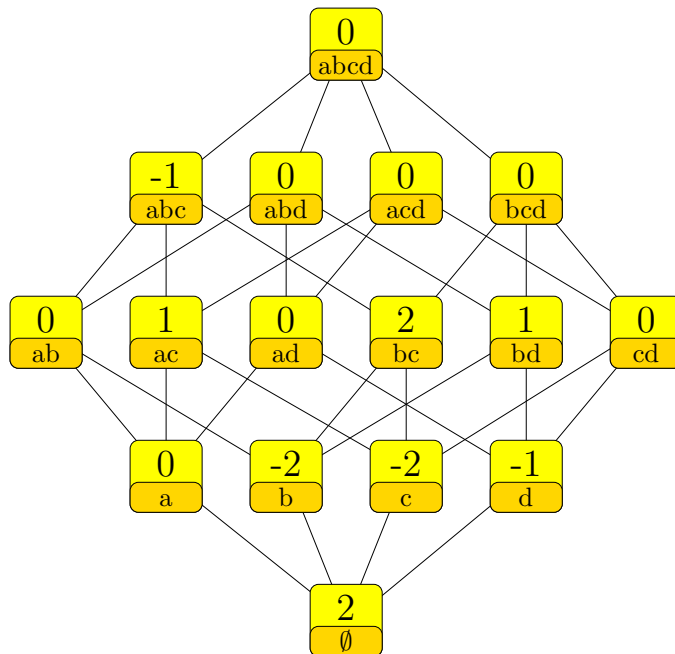

$$\begin{aligned}
 &+2\delta_\emptyset - 2\delta_{\{b\}} - 2\delta_{\{c\}} - \delta_{\{d\}} + \delta_{\{a,c\}} + 2\delta_{\{b,c\}} + \delta_{\{b,d\}} - \delta_{\{a,b,c\}} \\
 &= u_{\langle b,c|\emptyset \rangle} + u_{\langle b,d|\emptyset \rangle} - u_{\langle a,b|c \rangle} \\
 &= (+2\delta_\emptyset - \delta_{\{b\}} - \delta_{\{c\}} - \delta_{\{d\}} + \delta_{\{b,c\}} - \delta_{\{a,b,c\}} + \delta_{\{a,b,c,d\}}) \\
 &\quad - (\delta_{\{b\}} + \delta_{\{c\}} - \delta_{\{a,c\}} - \delta_{\{b,c\}} - \delta_{\{b,d\}} + \delta_{\{a,b,c,d\}})
 \end{aligned}$$

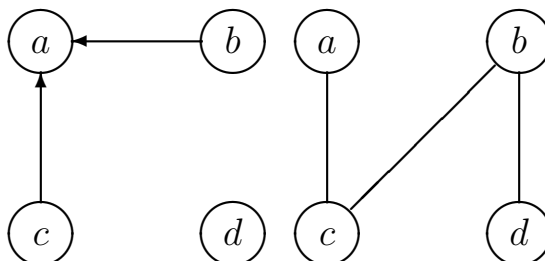

1.20.8.4 Differential imset (226)

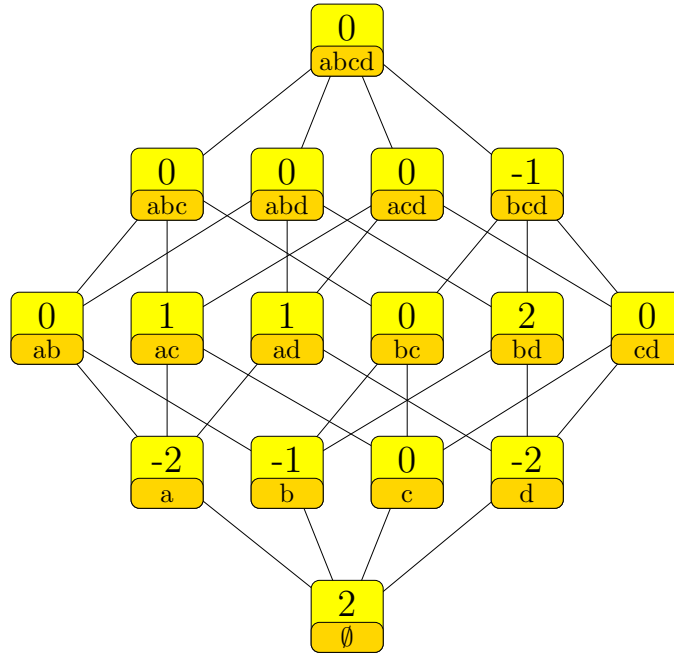

$$\begin{aligned}
 &+2\delta_\emptyset - 2\delta_{\{a\}} - \delta_{\{b\}} - 2\delta_{\{d\}} + \delta_{\{a,c\}} + \delta_{\{a,d\}} + 2\delta_{\{b,d\}} - \delta_{\{b,c,d\}} \\
 &= u_{\langle a,c|\emptyset \rangle} + u_{\langle a,d|\emptyset \rangle} - u_{\langle b,c|\emptyset \rangle} + u_{\langle b,d|\emptyset \rangle} - u_{\langle c,d|b \rangle} \\
 &= (+2\delta_\emptyset - \delta_{\{a\}} - \delta_{\{b\}} - \delta_{\{d\}} + \delta_{\{b,d\}} - \delta_{\{b,c,d\}} + \delta_{\{a,b,c,d\}}) \\
 &\quad - (\delta_{\{a\}} + \delta_{\{d\}} - \delta_{\{a,c\}} - \delta_{\{a,d\}} - \delta_{\{b,d\}} + \delta_{\{a,b,c,d\}})
 \end{aligned}$$

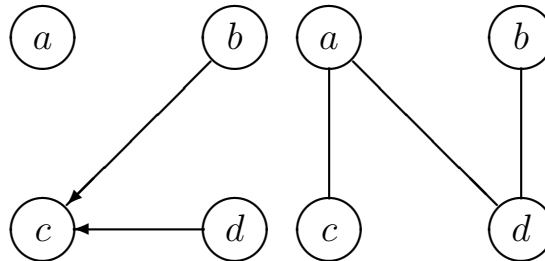

1.20.9 Number of nonzero values 9

1.20.9.1 Differential imset (227)

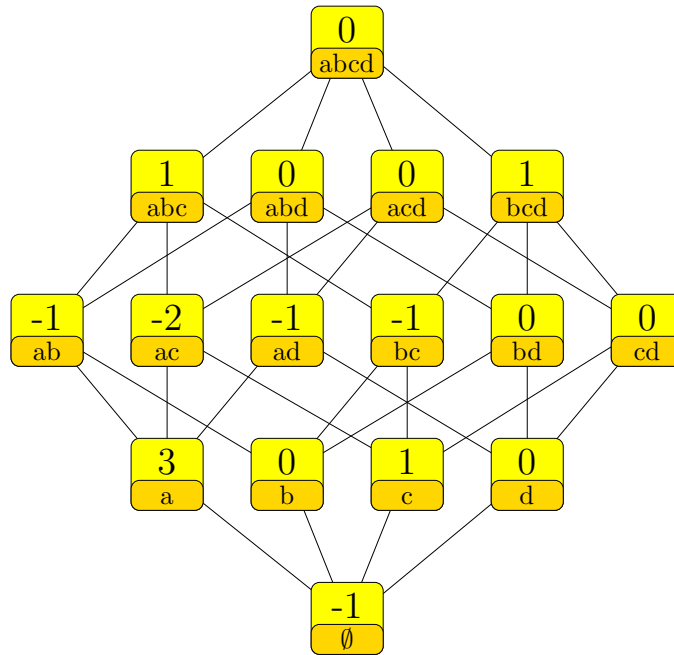

$$\begin{aligned}
 & -\delta_{\emptyset} + 3\delta_{\{a\}} + \delta_{\{c\}} - \delta_{\{a,b\}} - 2\delta_{\{a,c\}} - \delta_{\{a,d\}} - \delta_{\{b,c\}} + \delta_{\{a,b,c\}} + \delta_{\{b,c,d\}} \\
 &= -u_{\langle a,c|\emptyset\rangle} + u_{\langle c,d|ab\rangle} - u_{\langle a,d|bc\rangle} + u_{\langle b,c|a\rangle} + u_{\langle b,d|a\rangle} \\
 &= (+2\delta_{\{a\}} - \delta_{\{a,b\}} - \delta_{\{a,c\}} - \delta_{\{a,d\}} + \delta_{\{a,b,c,d\}}) \\
 &\quad - (\delta_{\emptyset} - \delta_{\{a\}} - \delta_{\{c\}} + \delta_{\{a,c\}} + \delta_{\{b,c\}} - \delta_{\{a,b,c\}} - \delta_{\{b,c,d\}} + \delta_{\{a,b,c,d\}})
 \end{aligned}$$

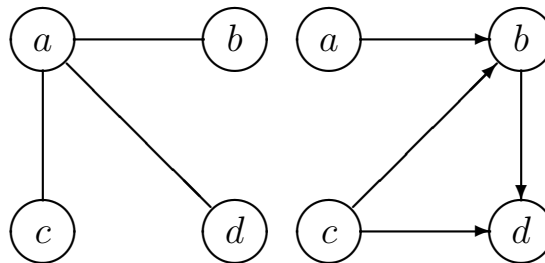

1.20.9.2 Differential imset (228)

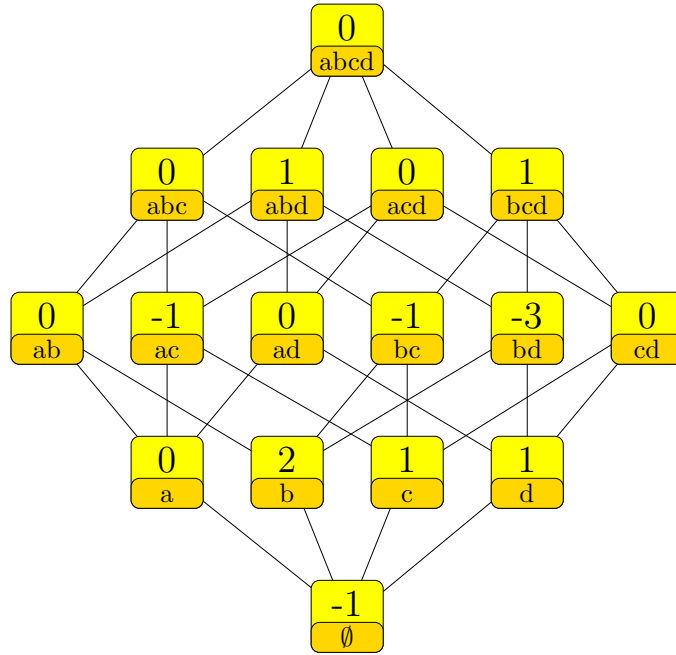

$$\begin{aligned}
 & -\delta_{\emptyset} + 2\delta_{\{b\}} + \delta_{\{c\}} + \delta_{\{d\}} - \delta_{\{a,c\}} - \delta_{\{b,c\}} - 3\delta_{\{b,d\}} + \delta_{\{a,b,d\}} + \delta_{\{b,c,d\}} \\
 &= -u_{\langle b,d|\emptyset \rangle} + u_{\langle c,d|ab \rangle} - u_{\langle a,c|bd \rangle} + u_{\langle a,d|b \rangle} + u_{\langle a,b|c \rangle} \\
 &= (\delta_{\{b\}} + \delta_{\{c\}} - \delta_{\{a,c\}} - \delta_{\{b,c\}} - \delta_{\{b,d\}} + \delta_{\{a,b,c,d\}}) \\
 &\quad - (\delta_{\emptyset} - \delta_{\{b\}} - \delta_{\{d\}} + 2\delta_{\{b,d\}} - \delta_{\{a,b,d\}} - \delta_{\{b,c,d\}} + \delta_{\{a,b,c,d\}})
 \end{aligned}$$

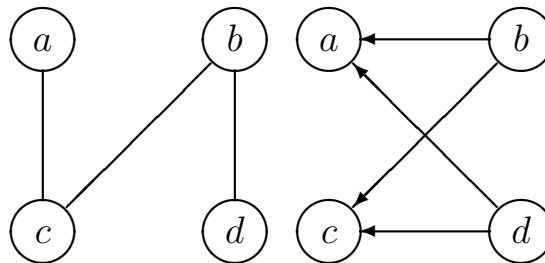

1.20.9.3 Differential imset (229)

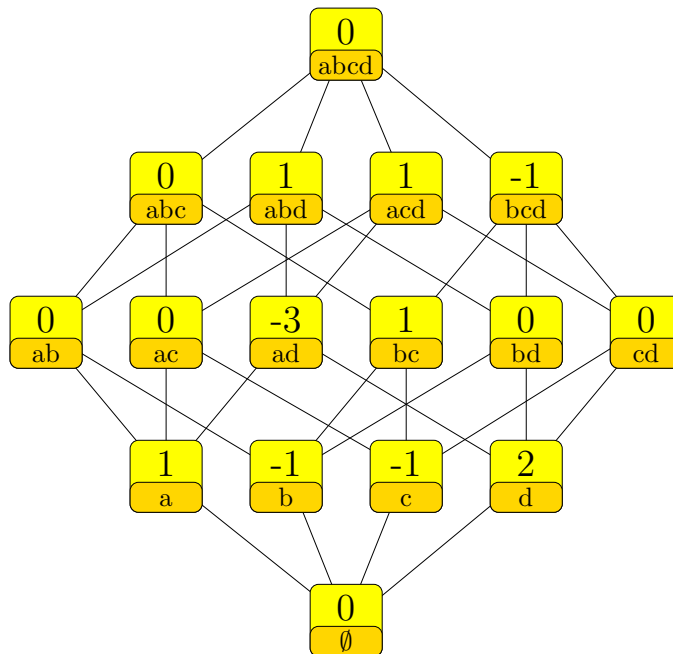

$$\begin{aligned}
 & \delta_{\{a\}} - \delta_{\{b\}} - \delta_{\{c\}} + 2\delta_{\{d\}} - 3\delta_{\{a,d\}} + \delta_{\{b,c\}} + \delta_{\{a,b,d\}} + \delta_{\{a,c,d\}} - \delta_{\{b,c,d\}} \\
 &= -u_{\langle a,d|\emptyset \rangle} + u_{\langle b,c|\emptyset \rangle} - u_{\langle b,c|ad \rangle} + u_{\langle a,c|bd \rangle} + u_{\langle a,b|d \rangle} \\
 &= (\delta_{\emptyset} - \delta_{\{b\}} - \delta_{\{c\}} + \delta_{\{d\}} - \delta_{\{a,d\}} + \delta_{\{b,c\}} - \delta_{\{b,c,d\}} + \delta_{\{a,b,c,d\}}) \\
 &\quad - (\delta_{\emptyset} - \delta_{\{a\}} - \delta_{\{d\}} + 2\delta_{\{a,d\}} - \delta_{\{a,b,d\}} - \delta_{\{a,c,d\}} + \delta_{\{a,b,c,d\}})
 \end{aligned}$$

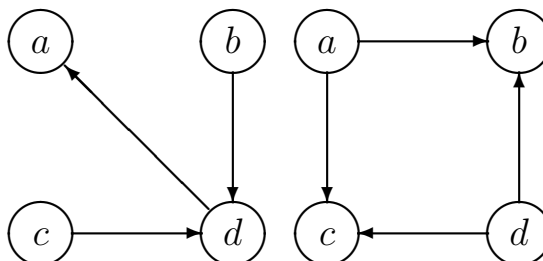

### 1.22 Squared Euclidean length 22

#### 1.22.8 Number of nonzero values 8

##### 1.22.8.1 Differential imset (230)

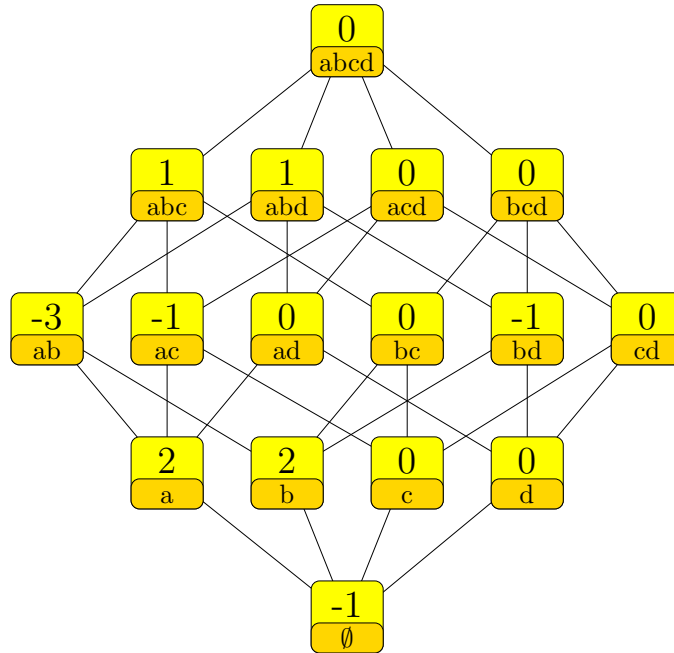

$$\begin{aligned}
 & -\delta_{\emptyset} + 2\delta_{\{a\}} + 2\delta_{\{b\}} - 3\delta_{\{a,b\}} - \delta_{\{a,c\}} - \delta_{\{b,d\}} + \delta_{\{a,b,c\}} + \delta_{\{a,b,d\}} \\
 &= -u_{\langle a,b|\emptyset \rangle} + u_{\langle b,c|a \rangle} + u_{\langle a,d|b \rangle} \\
 &= (\delta_{\{a\}} + \delta_{\{b\}} - \delta_{\{a,b\}} - \delta_{\{a,c\}} - \delta_{\{b,d\}} + \delta_{\{a,b,c,d\}}) \\
 &\quad - (\delta_{\emptyset} - \delta_{\{a\}} - \delta_{\{b\}} + 2\delta_{\{a,b\}} - \delta_{\{a,b,c\}} - \delta_{\{a,b,d\}} + \delta_{\{a,b,c,d\}})
 \end{aligned}$$

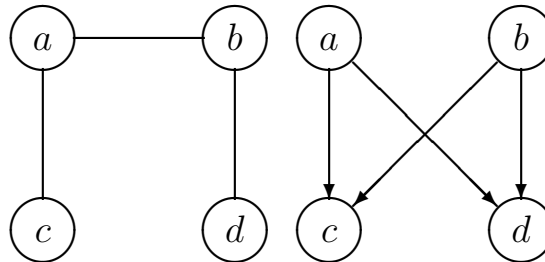

1.22.8.2 Differential imset (231)

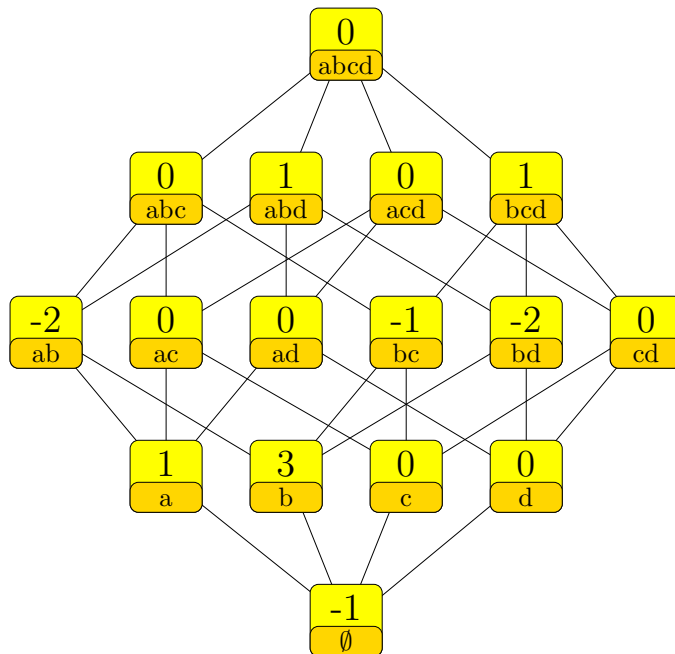

$$\begin{aligned}
 & -\delta_{\emptyset} + \delta_{\{a\}} + 3\delta_{\{b\}} - 2\delta_{\{a,b\}} - \delta_{\{b,c\}} - 2\delta_{\{b,d\}} + \delta_{\{a,b,d\}} + \delta_{\{b,c,d\}} \\
 & = -u_{\langle a,b|\emptyset \rangle} + u_{\langle a,d|b \rangle} + u_{\langle c,d|b \rangle} \\
 & = (+2\delta_{\{b\}} - \delta_{\{a,b\}} - \delta_{\{b,c\}} - \delta_{\{b,d\}} + \delta_{\{a,b,c,d\}}) \\
 & \quad - (\delta_{\emptyset} - \delta_{\{a\}} - \delta_{\{b\}} + \delta_{\{a,b\}} + \delta_{\{b,d\}} - \delta_{\{a,b,d\}} - \delta_{\{b,c,d\}} + \delta_{\{a,b,c,d\}})
 \end{aligned}$$

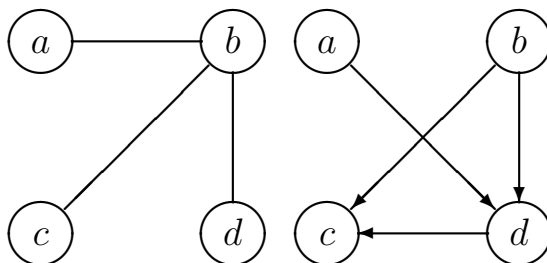



1.22.8.3 Differential imset (232)

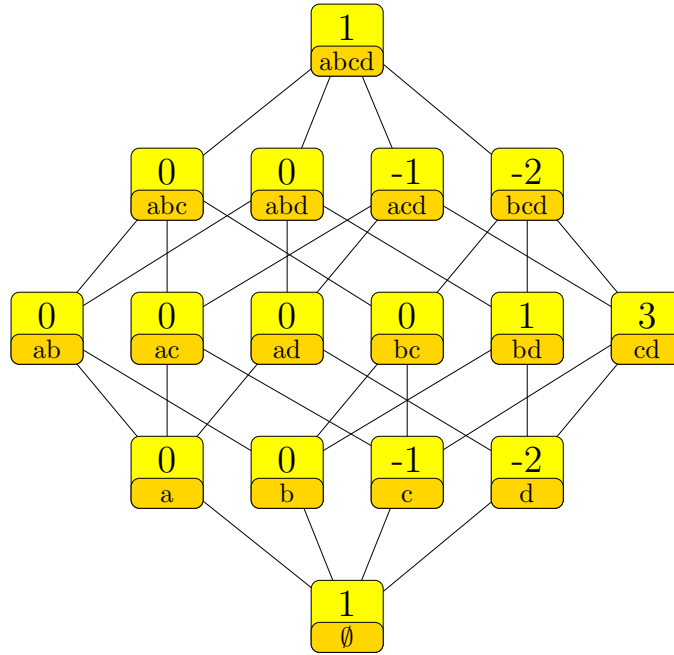

$$\begin{aligned}
 & \delta_\emptyset - \delta_{\{c\}} - 2\delta_{\{d\}} + \delta_{\{b,d\}} + 3\delta_{\{c,d\}} - \delta_{\{a,c,d\}} - 2\delta_{\{b,c,d\}} + \delta_{\{a,b,c,d\}} \\
 &= u_{\langle c,d|\emptyset \rangle} + u_{\langle a,b|cd \rangle} - u_{\langle b,c|d \rangle} \\
 &= (\delta_\emptyset - \delta_{\{c\}} - \delta_{\{d\}} + 2\delta_{\{c,d\}} - \delta_{\{a,c,d\}} - \delta_{\{b,c,d\}} + \delta_{\{a,b,c,d\}}) \\
 &\quad - (\delta_{\{d\}} - \delta_{\{b,d\}} - \delta_{\{c,d\}} + \delta_{\{b,c,d\}})
 \end{aligned}$$

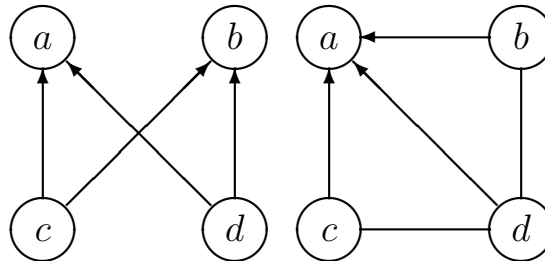



## Chapter 2

# Degree difference 2

### 2.4 Squared Euclidean length 4

#### 2.4.4 Number of nonzero values 4

##### 2.4.4.1 Differential imset (233)

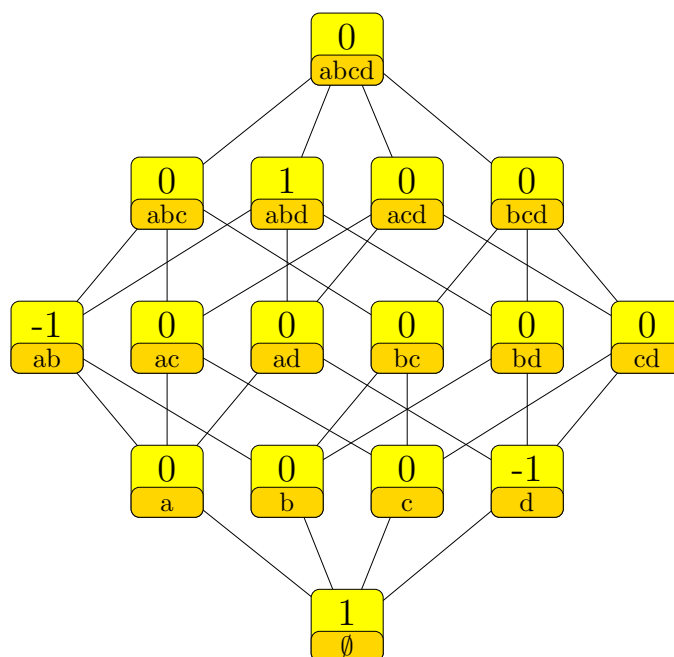

$$\begin{aligned}
 & \delta_{\emptyset} - \delta_{\{d\}} - \delta_{\{a,b\}} + \delta_{\{a,b,d\}} \\
 &= u_{\langle a,d|\emptyset \rangle} + u_{\langle b,d|a \rangle} \\
 &= (+3\delta_{\emptyset} - \delta_{\{a\}} - \delta_{\{b\}} - \delta_{\{c\}} - \delta_{\{d\}} + \delta_{\{a,b,c,d\}}) \\
 &\quad - (+2\delta_{\emptyset} - \delta_{\{a\}} - \delta_{\{b\}} - \delta_{\{c\}} + \delta_{\{a,b\}} - \delta_{\{a,b,d\}} + \delta_{\{a,b,c,d\}}) \\
 &= (\delta_{\emptyset} + \delta_{\{c\}} - \delta_{\{d\}} - \delta_{\{a,c\}} - \delta_{\{b,c\}} + \delta_{\{a,b,c,d\}}) \\
 &\quad - (\delta_{\{c\}} + \delta_{\{a,b\}} - \delta_{\{a,c\}} - \delta_{\{b,c\}} - \delta_{\{a,b,d\}} + \delta_{\{a,b,c,d\}}) \\
 &= (\delta_{\emptyset} - \delta_{\{d\}} - \delta_{\{a,b,c\}} + \delta_{\{a,b,c,d\}}) \\
 &\quad - (\delta_{\{a,b\}} - \delta_{\{a,b,c\}} - \delta_{\{a,b,d\}} + \delta_{\{a,b,c,d\}})
 \end{aligned}$$

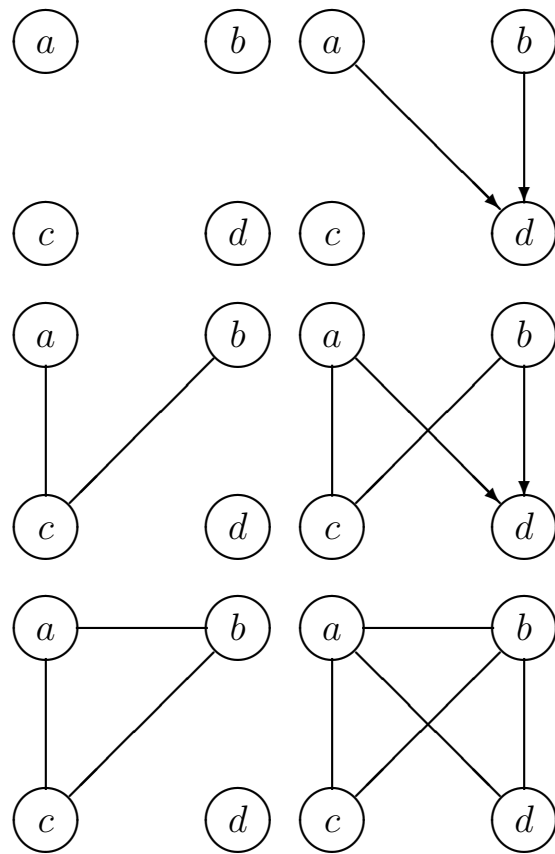

2.4.4.2 Differential imset (234)

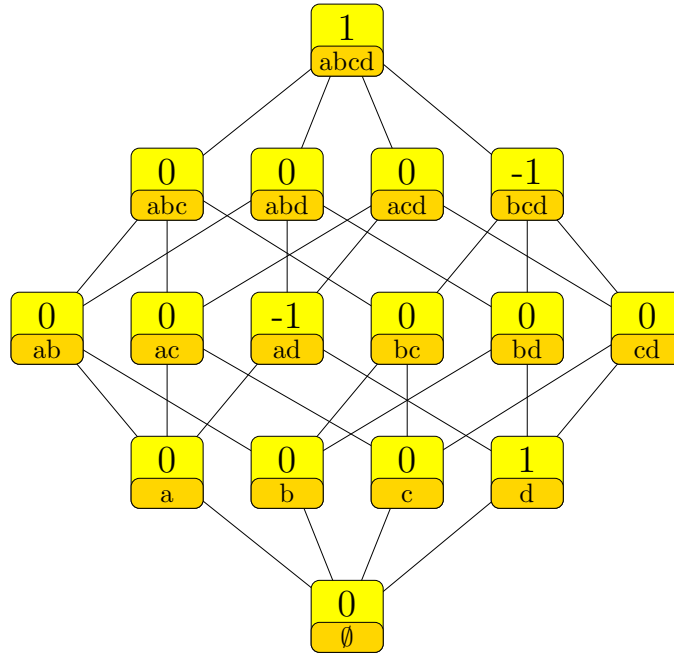

$$\begin{aligned}
 & \delta_{\{d\}} - \delta_{\{a,d\}} - \delta_{\{b,c,d\}} + \delta_{\{a,b,c,d\}} \\
 &= u_{\langle a,c|bd \rangle} + u_{\langle a,b|d \rangle} \\
 &= (\delta_{\{b\}} + \delta_{\{d\}} - \delta_{\{a,d\}} - \delta_{\{b,c\}} - \delta_{\{b,d\}} + \delta_{\{a,b,c,d\}}) \\
 &\quad - (\delta_{\{b\}} - \delta_{\{b,c\}} - \delta_{\{b,d\}} + \delta_{\{b,c,d\}})
 \end{aligned}$$

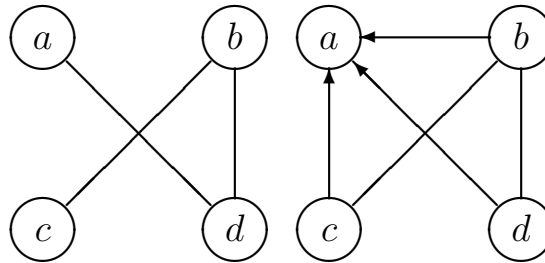

## 2.6 Squared Euclidean length 6

### 2.6.6 Number of nonzero values 6

#### 2.6.6.1 Differential inset (235)

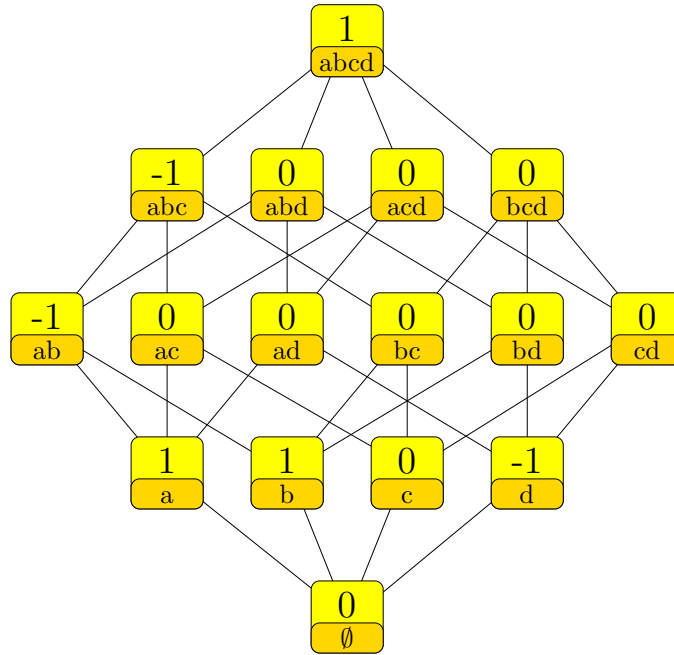

$$\begin{aligned}
 & \delta_{\{a\}} + \delta_{\{b\}} - \delta_{\{d\}} - \delta_{\{a,b\}} - \delta_{\{a,b,c\}} + \delta_{\{a,b,c,d\}} \\
 &= -u_{\langle a,b|\emptyset \rangle} + u_{\langle a,d|\emptyset \rangle} + u_{\langle c,d|ab \rangle} + u_{\langle b,d|a \rangle} \\
 &= (+2\delta_{\emptyset} - \delta_{\{c\}} - \delta_{\{d\}} - \delta_{\{a,b\}} + \delta_{\{a,b,c,d\}}) \\
 &\quad - (+2\delta_{\emptyset} - \delta_{\{a\}} - \delta_{\{b\}} - \delta_{\{c\}} + \delta_{\{a,b,c\}})
 \end{aligned}$$

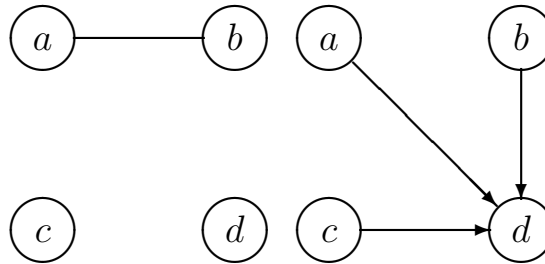

2.6.6.2 Differential inset (236)

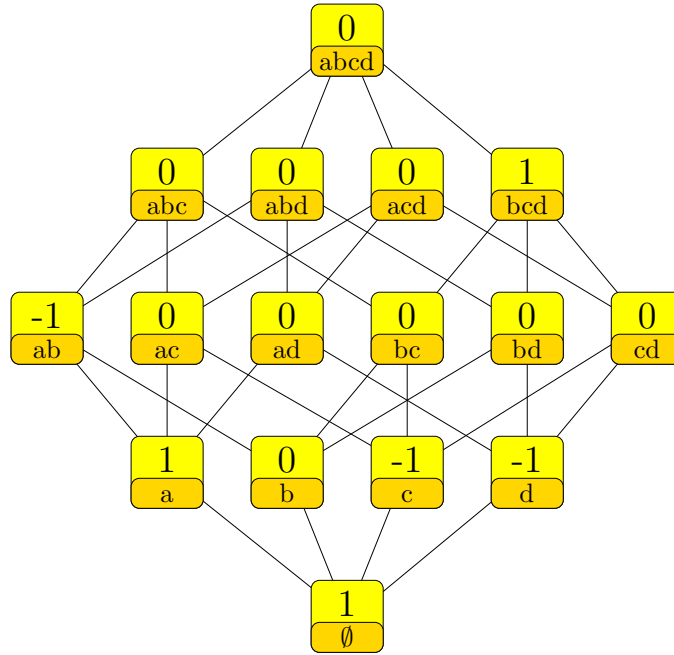

$$\begin{aligned}
 & \delta_\emptyset + \delta_{\{a\}} - \delta_{\{c\}} - \delta_{\{d\}} - \delta_{\{a,b\}} + \delta_{\{b,c,d\}} \\
 &= -u_{\langle a,b|\emptyset \rangle} + u_{\langle b,c|\emptyset \rangle} + u_{\langle b,d|\emptyset \rangle} + u_{\langle c,d|b \rangle} \\
 &= (+2\delta_\emptyset - \delta_{\{b\}} - \delta_{\{c\}} - \delta_{\{d\}} + \delta_{\{b,d\}} - \delta_{\{a,b,d\}} + \delta_{\{a,b,c,d\}}) \\
 &\quad - (\delta_\emptyset - \delta_{\{a\}} - \delta_{\{b\}} + \delta_{\{a,b\}} + \delta_{\{b,d\}} - \delta_{\{a,b,d\}} - \delta_{\{b,c,d\}} + \delta_{\{a,b,c,d\}})
 \end{aligned}$$

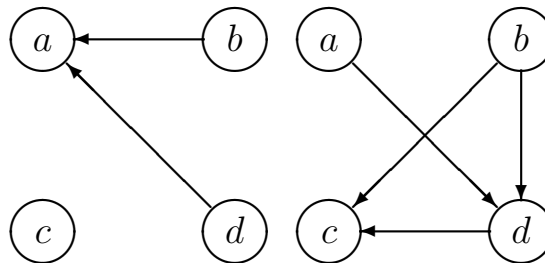

2.6.6.3 Differential imset (237)

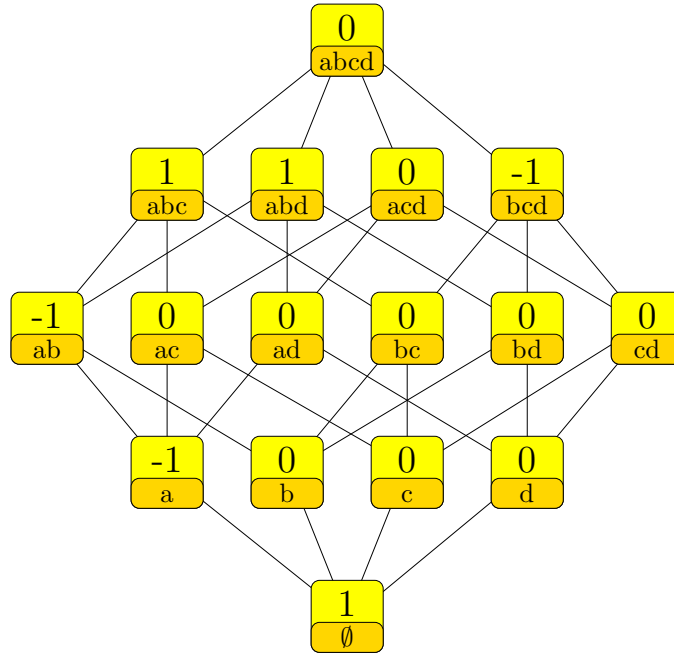

$$\begin{aligned}
 & \delta_\emptyset - \delta_{\{a\}} - \delta_{\{a,b\}} + \delta_{\{a,b,c\}} + \delta_{\{a,b,d\}} - \delta_{\{b,c,d\}} \\
 &= u_{\langle a,b|\emptyset \rangle} - u_{\langle c,d|ab \rangle} + u_{\langle a,d|bc \rangle} + u_{\langle a,c|b \rangle} \\
 &= (+2\delta_\emptyset - \delta_{\{a\}} - \delta_{\{b\}} - \delta_{\{d\}} + \delta_{\{b,d\}} - \delta_{\{b,c,d\}} + \delta_{\{a,b,c,d\}}) \\
 &\quad - (\delta_\emptyset - \delta_{\{b\}} - \delta_{\{d\}} + \delta_{\{a,b\}} + \delta_{\{b,d\}} - \delta_{\{a,b,c\}} - \delta_{\{a,b,d\}} + \delta_{\{a,b,c,d\}}) \\
 &= (\delta_\emptyset - \delta_{\{a\}} - \delta_{\{b,c,d\}} + \delta_{\{a,b,c,d\}}) \\
 &\quad - (\delta_{\{a,b\}} - \delta_{\{a,b,c\}} - \delta_{\{a,b,d\}} + \delta_{\{a,b,c,d\}})
 \end{aligned}$$

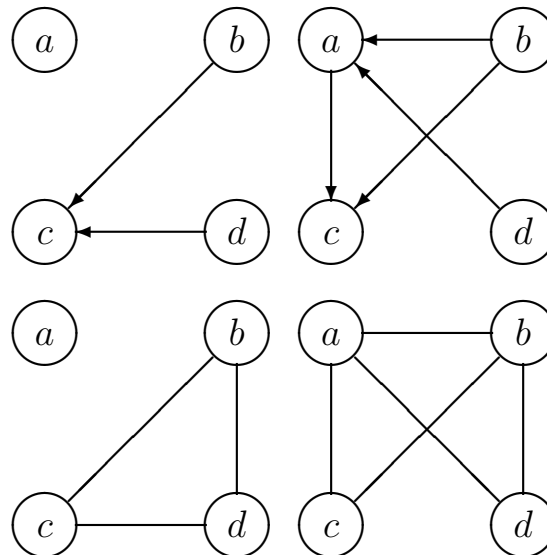



2.6.6.4 Differential imset (238)

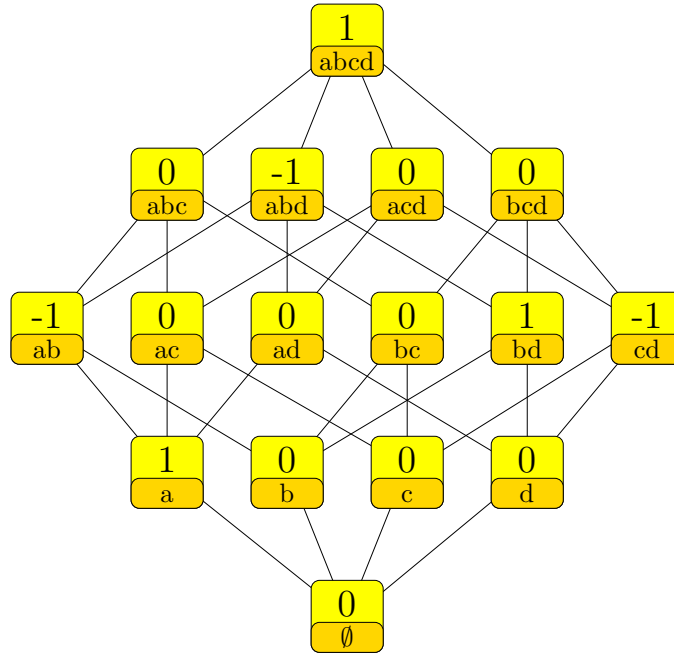

$$\begin{aligned}
 & \delta_{\{a\}} - \delta_{\{a,b\}} + \delta_{\{b,d\}} - \delta_{\{c,d\}} - \delta_{\{a,b,d\}} + \delta_{\{a,b,c,d\}} \\
 &= -u_{\langle a,b|\emptyset \rangle} + u_{\langle b,c|\emptyset \rangle} + u_{\langle a,c|bd \rangle} + u_{\langle b,d|c \rangle} \\
 &= (\delta_\emptyset - \delta_{\{a,b\}} - \delta_{\{c,d\}} + \delta_{\{a,b,c,d\}}) \\
 &\quad - (\delta_\emptyset - \delta_{\{a\}} - \delta_{\{b,d\}} + \delta_{\{a,b,d\}})
 \end{aligned}$$

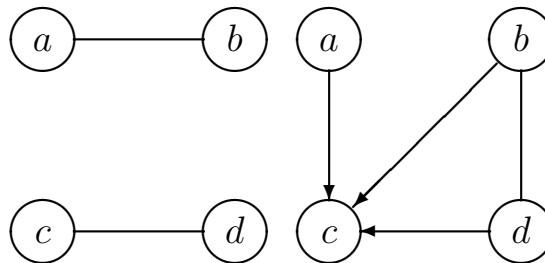

2.6.6.5 Differential inset (239)

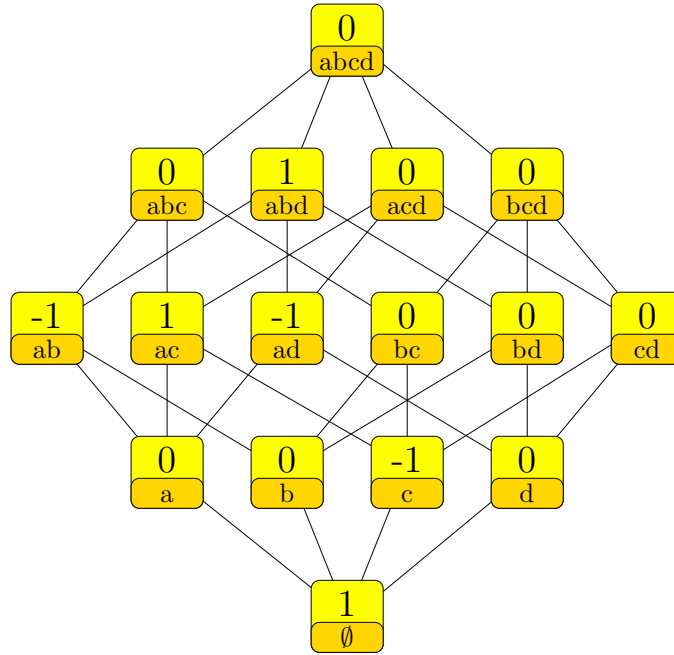

$$\begin{aligned}
 & \delta_\emptyset - \delta_{\{c\}} - \delta_{\{a,b\}} + \delta_{\{a,c\}} - \delta_{\{a,d\}} + \delta_{\{a,b,d\}} \\
 &= u_{\langle a,c|\emptyset \rangle} + u_{\langle b,d|a \rangle} \\
 &= (+2\delta_\emptyset - \delta_{\{c\}} - \delta_{\{d\}} - \delta_{\{a,b\}} + \delta_{\{a,b,c,d\}}) \\
 &\quad - (\delta_\emptyset - \delta_{\{d\}} - \delta_{\{a,c\}} + \delta_{\{a,d\}} - \delta_{\{a,b,d\}} + \delta_{\{a,b,c,d\}}) \\
 &= (\delta_\emptyset - \delta_{\{c\}} - \delta_{\{a,b\}} + \delta_{\{a,c\}} - \delta_{\{a,c,d\}} + \delta_{\{a,b,c,d\}}) \\
 &\quad - (\delta_{\{a,d\}} - \delta_{\{a,b,d\}} - \delta_{\{a,c,d\}} + \delta_{\{a,b,c,d\}})
 \end{aligned}$$

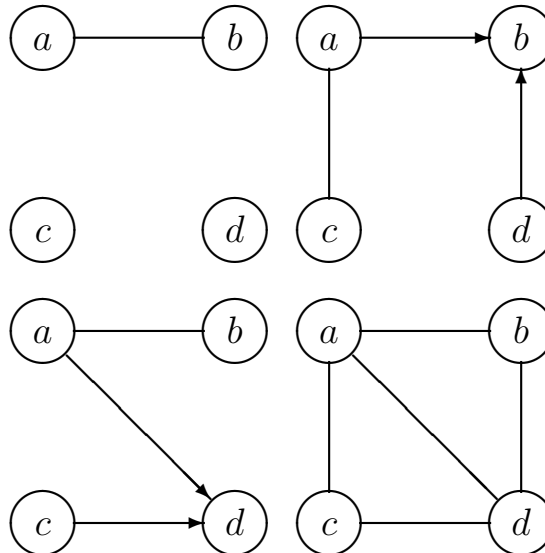

2.6.6.6 Differential inset (240)

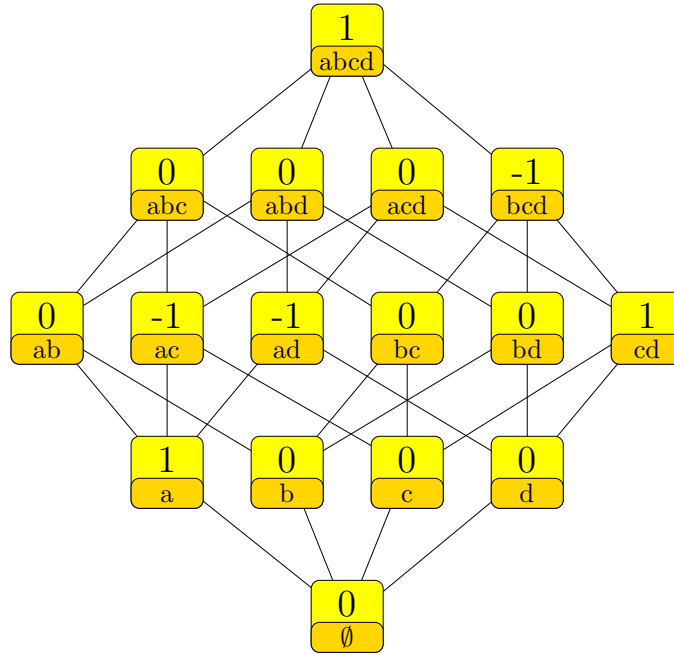

$$\begin{aligned}
 & \delta_{\{a\}} - \delta_{\{a,c\}} - \delta_{\{a,d\}} + \delta_{\{c,d\}} - \delta_{\{b,c,d\}} + \delta_{\{a,b,c,d\}} \\
 &= u_{\langle a,b|cd \rangle} + u_{\langle c,d|a \rangle} \\
 &= (\delta_{\{a\}} + \delta_{\{c\}} - \delta_{\{a,c\}} - \delta_{\{a,d\}} - \delta_{\{b,c\}} + \delta_{\{a,b,c,d\}}) \\
 &\quad - (\delta_{\{c\}} - \delta_{\{b,c\}} - \delta_{\{c,d\}} + \delta_{\{b,c,d\}}) \\
 &= (\delta_{\{a\}} + \delta_{\{d\}} - \delta_{\{a,c\}} - \delta_{\{a,d\}} - \delta_{\{b,d\}} + \delta_{\{a,b,c,d\}}) \\
 &\quad - (\delta_{\{d\}} - \delta_{\{b,d\}} - \delta_{\{c,d\}} + \delta_{\{b,c,d\}})
 \end{aligned}$$

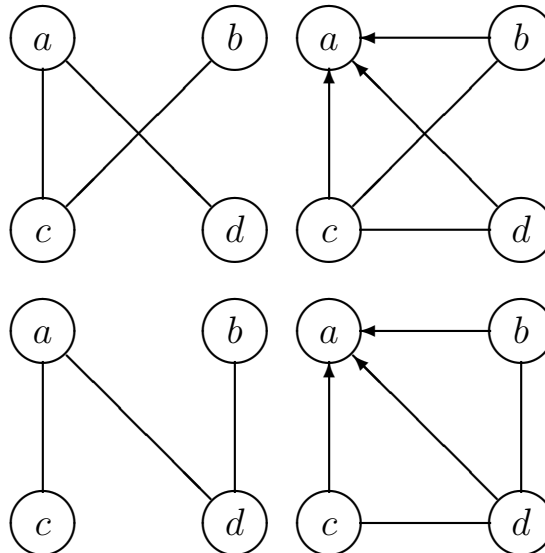

2.6.6.7 Differential inset (241)

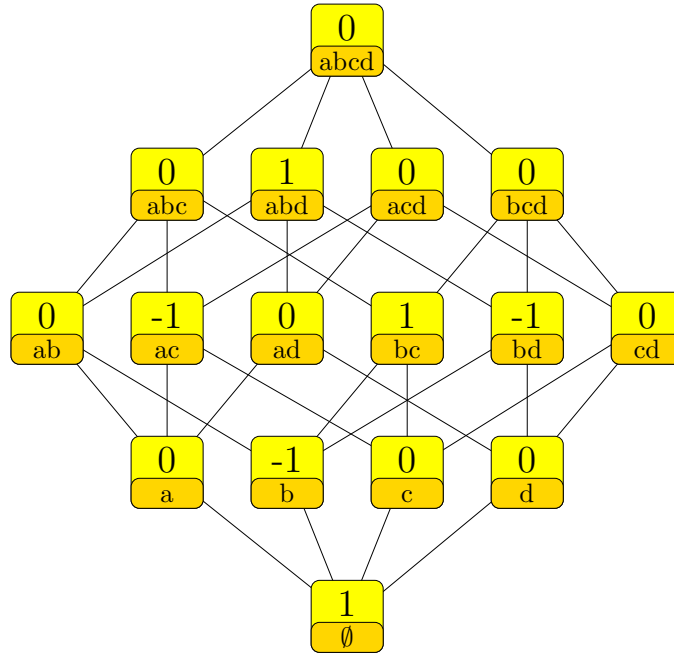

$$\begin{aligned}
 & \delta_\emptyset - \delta_{\{b\}} - \delta_{\{a,c\}} + \delta_{\{b,c\}} - \delta_{\{b,d\}} + \delta_{\{a,b,d\}} \\
 &= u_{\langle a,b|\emptyset \rangle} - u_{\langle a,c|\emptyset \rangle} + u_{\langle b,c|\emptyset \rangle} + u_{\langle a,d|b \rangle} \\
 &= (+2\delta_\emptyset - \delta_{\{b\}} - \delta_{\{d\}} - \delta_{\{a,c\}} + \delta_{\{a,b,c,d\}}) \\
 &\quad - (\delta_\emptyset - \delta_{\{d\}} - \delta_{\{b,c\}} + \delta_{\{b,d\}} - \delta_{\{a,b,d\}} + \delta_{\{a,b,c,d\}}) \\
 &= (\delta_\emptyset - \delta_{\{b\}} + \delta_{\{c\}} - \delta_{\{a,c\}} - \delta_{\{c,d\}} + \delta_{\{a,b,c,d\}}) \\
 &\quad - (\delta_{\{c\}} - \delta_{\{b,c\}} + \delta_{\{b,d\}} - \delta_{\{c,d\}} - \delta_{\{a,b,d\}} + \delta_{\{a,b,c,d\}}) \\
 &= (\delta_\emptyset - \delta_{\{b\}} - \delta_{\{a,c\}} + \delta_{\{b,c\}} - \delta_{\{b,c,d\}} + \delta_{\{a,b,c,d\}}) \\
 &\quad - (\delta_{\{b,d\}} - \delta_{\{a,b,d\}} - \delta_{\{b,c,d\}} + \delta_{\{a,b,c,d\}})
 \end{aligned}$$

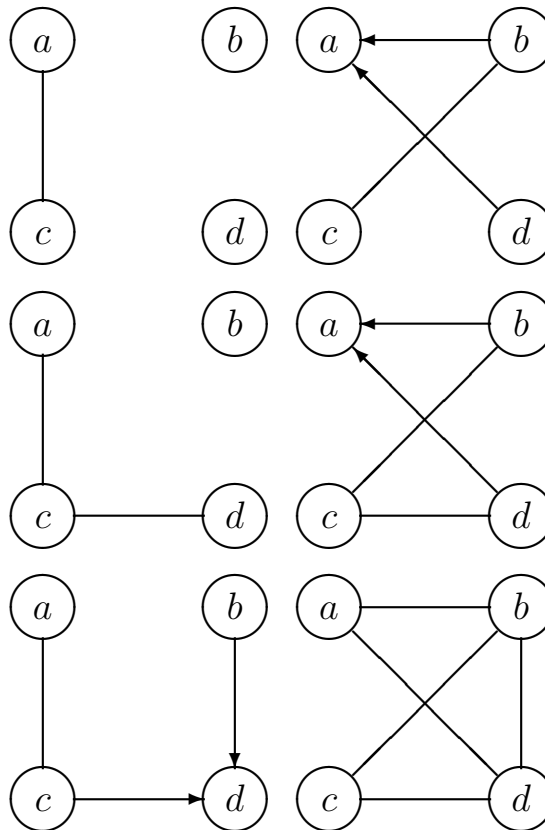

## 2.8 Squared Euclidean length 8

### 2.8.8 Number of nonzero values 8

#### 2.8.8.1 Differential inset (242)

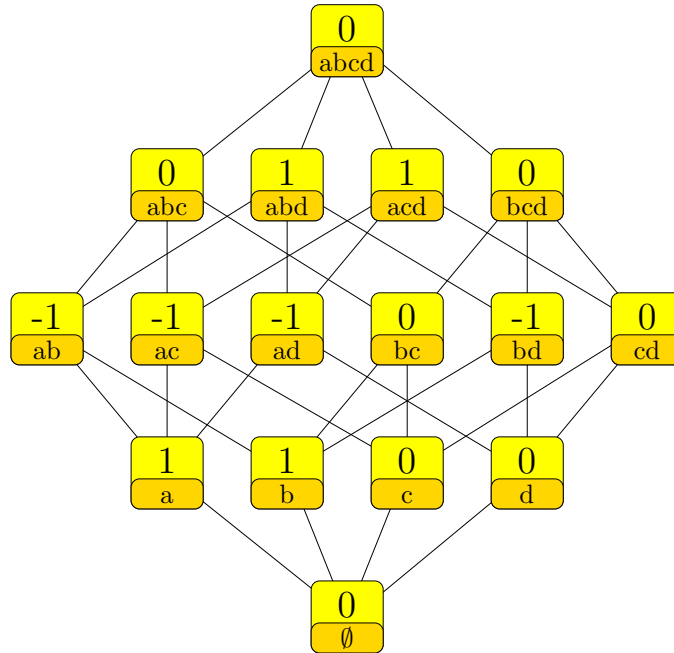

$$\begin{aligned}
 & \delta_{\{a\}} + \delta_{\{b\}} - \delta_{\{a,b\}} - \delta_{\{a,c\}} - \delta_{\{a,d\}} - \delta_{\{b,d\}} + \delta_{\{a,b,d\}} + \delta_{\{a,c,d\}} \\
 &= u_{\langle a,d|b \rangle} + u_{\langle c,d|a \rangle} \\
 &= (\delta_{\emptyset} + \delta_{\{b\}} - \delta_{\{c\}} - \delta_{\{a,b\}} - \delta_{\{b,d\}} + \delta_{\{a,b,c,d\}}) \\
 &\quad - (\delta_{\emptyset} - \delta_{\{a\}} - \delta_{\{c\}} + \delta_{\{a,c\}} + \delta_{\{a,d\}} - \delta_{\{a,b,d\}} - \delta_{\{a,c,d\}} + \delta_{\{a,b,c,d\}})
 \end{aligned}$$

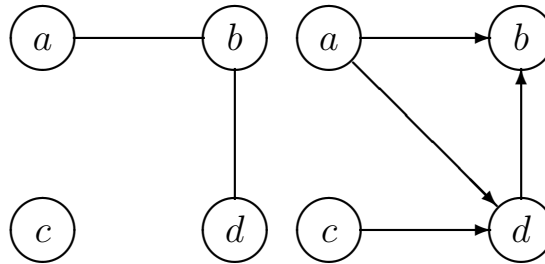

2.8.8.2 Differential imset (243)

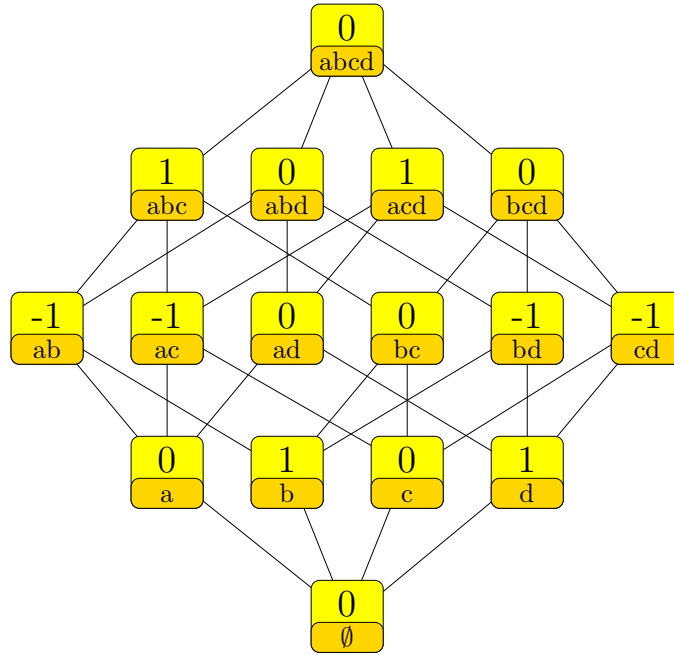

$$\begin{aligned}
 & \delta_{\{b\}} + \delta_{\{d\}} - \delta_{\{a,b\}} - \delta_{\{a,c\}} - \delta_{\{b,d\}} - \delta_{\{c,d\}} + \delta_{\{a,b,c\}} + \delta_{\{a,c,d\}} \\
 &= -u_{\langle b,d|ac \rangle} + u_{\langle a,d|bc \rangle} + u_{\langle a,c|b \rangle} + u_{\langle b,c|d \rangle} \\
 &= (\delta_{\emptyset} - \delta_{\{a\}} + \delta_{\{d\}} - \delta_{\{b,d\}} - \delta_{\{c,d\}} + \delta_{\{a,b,c,d\}}) \\
 &\quad - (\delta_{\emptyset} - \delta_{\{a\}} - \delta_{\{b\}} + \delta_{\{a,b\}} + \delta_{\{a,c\}} - \delta_{\{a,b,c\}} - \delta_{\{a,c,d\}} + \delta_{\{a,b,c,d\}}) \\
 &= (\delta_{\{b\}} + \delta_{\{d\}} - \delta_{\{a,b\}} - \delta_{\{b,d\}} - \delta_{\{c,d\}} + \delta_{\{a,b,c,d\}}) \\
 &\quad - (\delta_{\{a,c\}} - \delta_{\{a,b,c\}} - \delta_{\{a,c,d\}} + \delta_{\{a,b,c,d\}})
 \end{aligned}$$

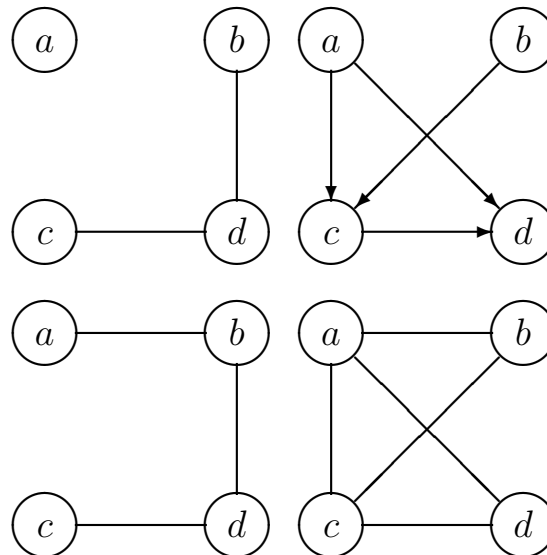

2.8.8.3 Differential inset (244)

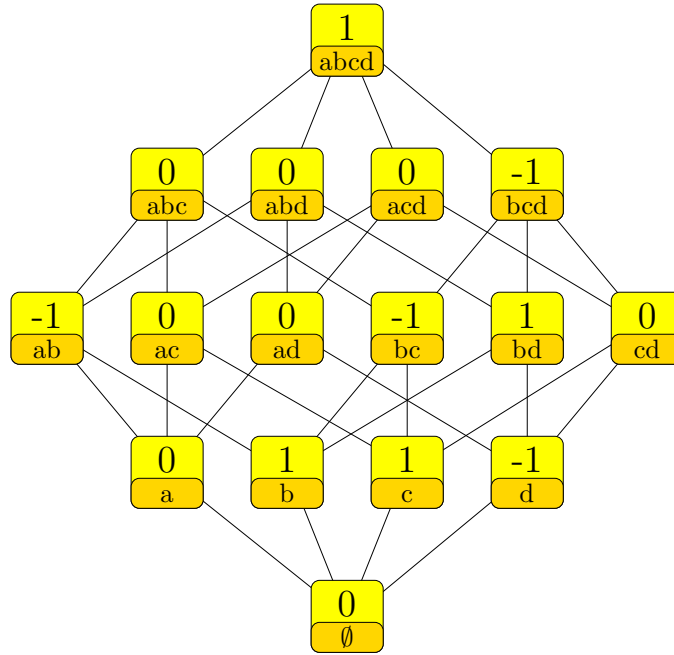

$$\begin{aligned}
 & \delta_{\{b\}} + \delta_{\{c\}} - \delta_{\{d\}} - \delta_{\{a,b\}} - \delta_{\{b,c\}} + \delta_{\{b,d\}} - \delta_{\{b,c,d\}} + \delta_{\{a,b,c,d\}} \\
 &= u_{\langle b,d|ac \rangle} + u_{\langle a,c|b \rangle} + u_{\langle a,d|c \rangle} - u_{\langle b,c|d \rangle} \\
 &= (\delta_{\{b\}} + \delta_{\{c\}} - \delta_{\{a,b\}} - \delta_{\{b,c\}} - \delta_{\{c,d\}} + \delta_{\{a,b,c,d\}}) \\
 &\quad - (\delta_{\{d\}} - \delta_{\{b,d\}} - \delta_{\{c,d\}} + \delta_{\{b,c,d\}})
 \end{aligned}$$

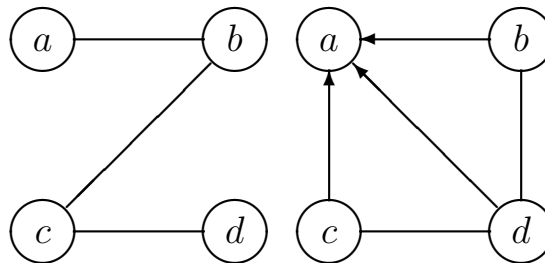

2.8.8.4 Differential imset (245)

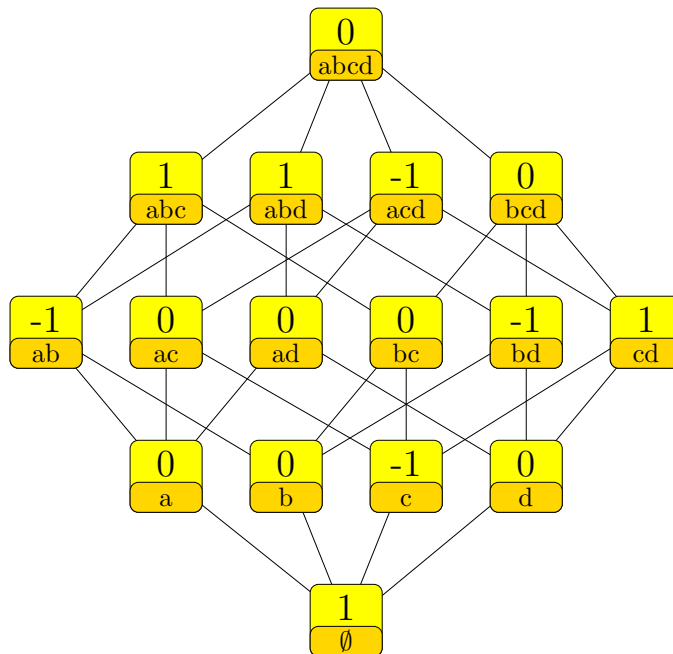

$$\begin{aligned}
 & \delta_{\emptyset} - \delta_{\{c\}} - \delta_{\{a,b\}} - \delta_{\{b,d\}} + \delta_{\{c,d\}} + \delta_{\{a,b,c\}} + \delta_{\{a,b,d\}} - \delta_{\{a,c,d\}} \\
 &= u_{\langle a,c|\emptyset \rangle} - u_{\langle a,c|bd \rangle} + u_{\langle a,b|cd \rangle} + u_{\langle b,c|a \rangle} \\
 &= (+2\delta_{\emptyset} - \delta_{\{b\}} - \delta_{\{c\}} - \delta_{\{d\}} + \delta_{\{c,d\}} - \delta_{\{a,c,d\}} + \delta_{\{a,b,c,d\}}) \\
 &\quad - (\delta_{\emptyset} - \delta_{\{b\}} - \delta_{\{d\}} + \delta_{\{a,b\}} + \delta_{\{b,d\}} - \delta_{\{a,b,c\}} - \delta_{\{a,b,d\}} + \delta_{\{a,b,c,d\}})
 \end{aligned}$$

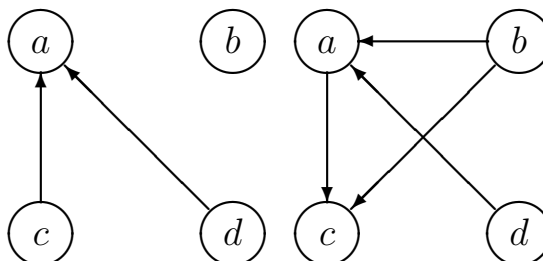



2.8.8.5 Differential inset (246)

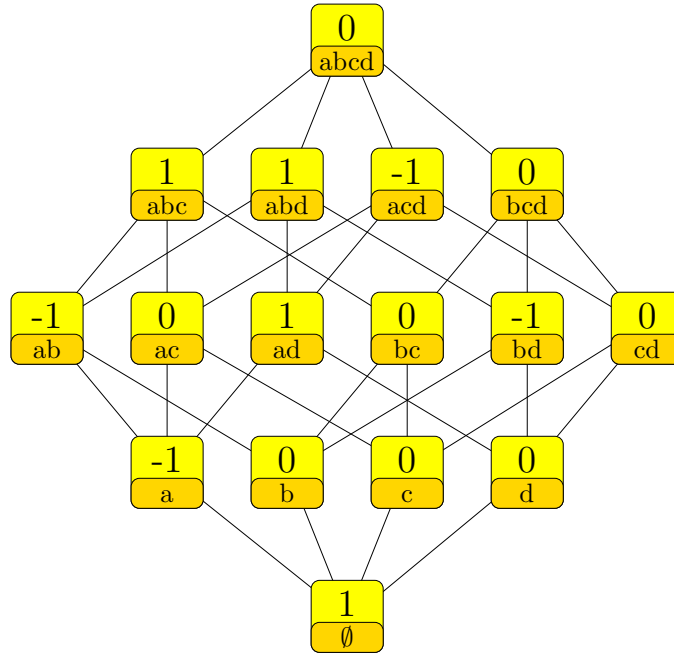

$$\begin{aligned}
 & \delta_\emptyset - \delta_{\{a\}} - \delta_{\{a,b\}} + \delta_{\{a,d\}} - \delta_{\{b,d\}} + \delta_{\{a,b,c\}} + \delta_{\{a,b,d\}} - \delta_{\{a,c,d\}} \\
 &= u_{\langle a,b|\emptyset \rangle} - u_{\langle c,d|ab \rangle} + u_{\langle b,c|ad \rangle} + u_{\langle a,d|b \rangle} \\
 &= (+2\delta_\emptyset - \delta_{\{a\}} - \delta_{\{b\}} - \delta_{\{d\}} + \delta_{\{a,d\}} - \delta_{\{a,c,d\}} + \delta_{\{a,b,c,d\}}) \\
 &\quad - (\delta_\emptyset - \delta_{\{b\}} - \delta_{\{d\}} + \delta_{\{a,b\}} + \delta_{\{b,d\}} - \delta_{\{a,b,c\}} - \delta_{\{a,b,d\}} + \delta_{\{a,b,c,d\}}) \\
 &= (\delta_\emptyset - \delta_{\{a\}} + \delta_{\{a,d\}} - \delta_{\{b,d\}} - \delta_{\{a,c,d\}} + \delta_{\{a,b,c,d\}}) \\
 &\quad - (\delta_{\{a,b\}} - \delta_{\{a,b,c\}} - \delta_{\{a,b,d\}} + \delta_{\{a,b,c,d\}})
 \end{aligned}$$

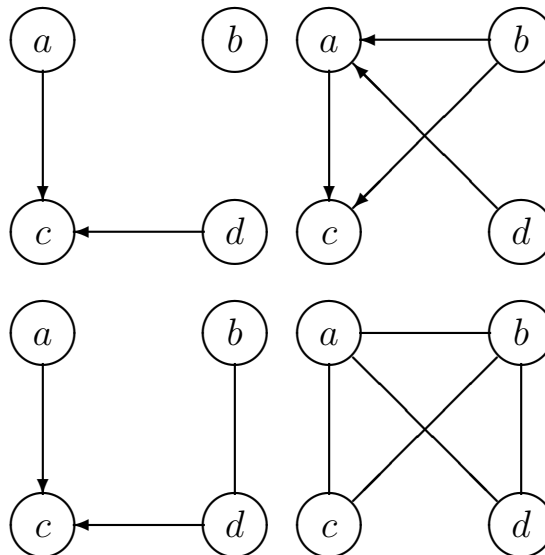

2.8.8.6 Differential imset (247)

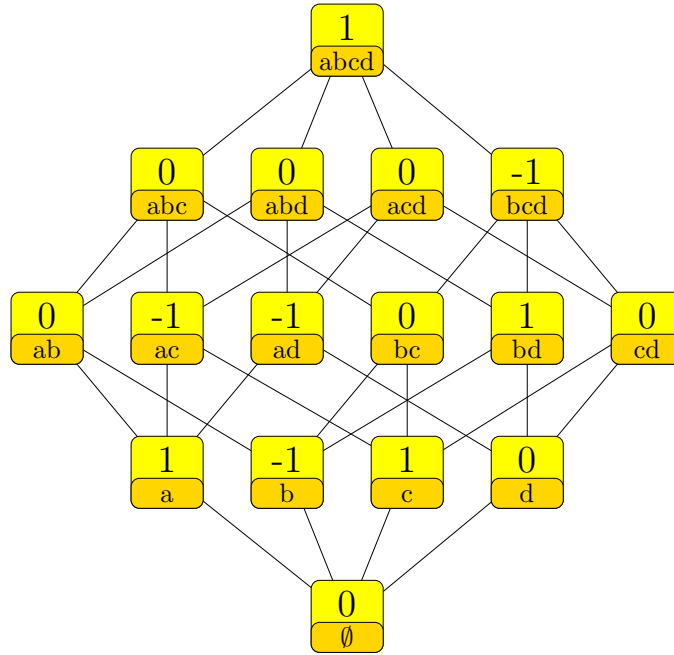

$$\begin{aligned}
 & \delta_{\{a\}} - \delta_{\{b\}} + \delta_{\{c\}} - \delta_{\{a,c\}} - \delta_{\{a,d\}} + \delta_{\{b,d\}} - \delta_{\{b,c,d\}} + \delta_{\{a,b,c,d\}} \\
 &= u_{\langle c,d|ab \rangle} + u_{\langle b,d|a \rangle} + u_{\langle a,b|c \rangle} - u_{\langle c,d|b \rangle} \\
 &= (\delta_{\{a\}} + \delta_{\{c\}} - \delta_{\{a,c\}} - \delta_{\{a,d\}} - \delta_{\{b,c\}} + \delta_{\{a,b,c,d\}}) \\
 &\quad - (\delta_{\{b\}} - \delta_{\{b,c\}} - \delta_{\{b,d\}} + \delta_{\{b,c,d\}})
 \end{aligned}$$

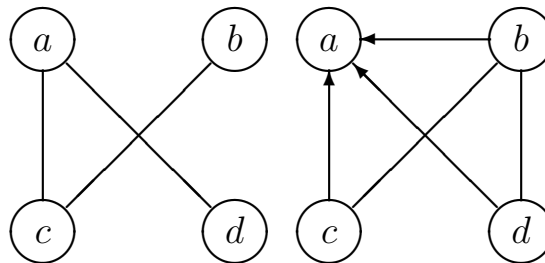

2.8.8.7 Differential inset (248)

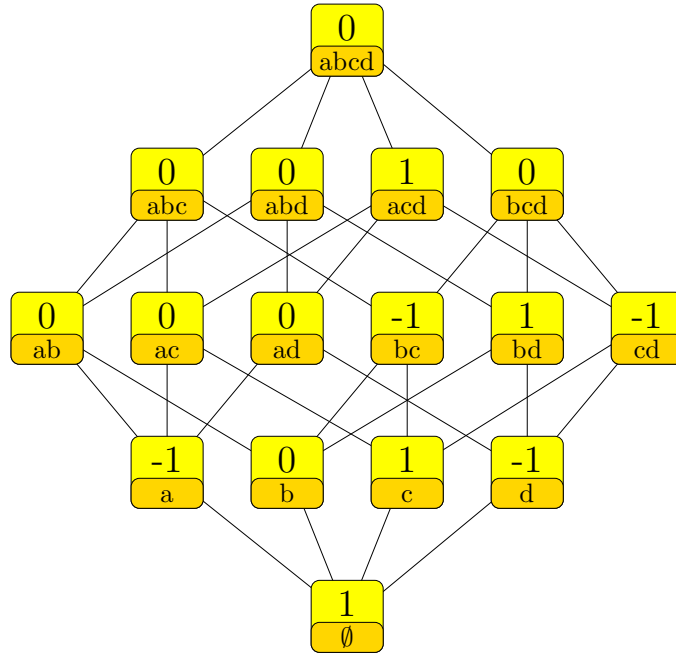

$$\begin{aligned}
 & \delta_\emptyset - \delta_{\{a\}} + \delta_{\{c\}} - \delta_{\{d\}} - \delta_{\{b,c\}} + \delta_{\{b,d\}} - \delta_{\{c,d\}} + \delta_{\{a,c,d\}} \\
 &= u_{\langle a,c|\emptyset \rangle} - u_{\langle b,c|\emptyset \rangle} + u_{\langle b,d|\emptyset \rangle} + u_{\langle a,d|c \rangle} \\
 &= (+2\delta_\emptyset - \delta_{\{a\}} - \delta_{\{d\}} - \delta_{\{b,c\}} + \delta_{\{a,b,c,d\}}) \\
 &\quad - (\delta_\emptyset - \delta_{\{c\}} - \delta_{\{b,d\}} + \delta_{\{c,d\}} - \delta_{\{a,c,d\}} + \delta_{\{a,b,c,d\}})
 \end{aligned}$$

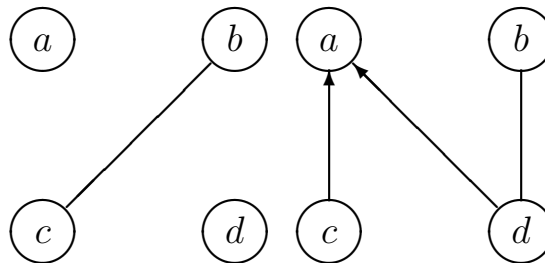

2.8.8.8 Differential inset (249)

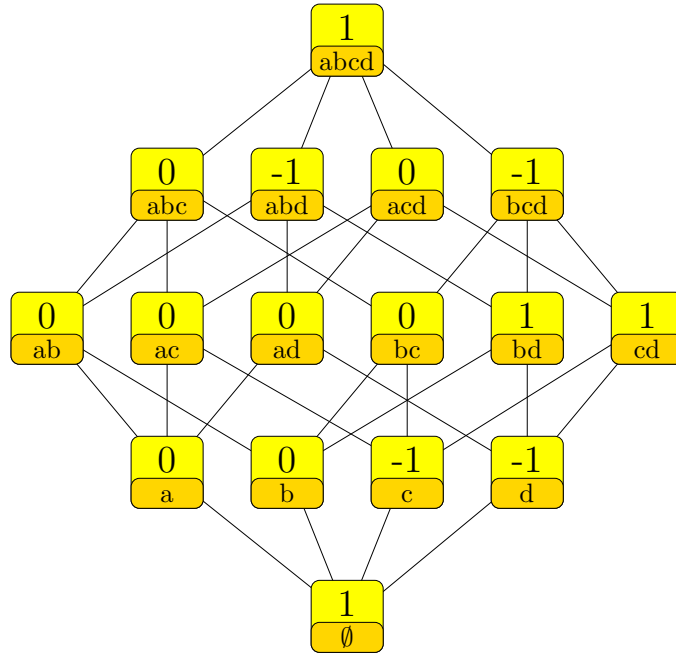

$$\begin{aligned}
 & \delta_\emptyset - \delta_{\{c\}} - \delta_{\{d\}} + \delta_{\{b,d\}} + \delta_{\{c,d\}} - \delta_{\{a,b,d\}} - \delta_{\{b,c,d\}} + \delta_{\{a,b,c,d\}} \\
 &= u_{\langle c,d|\emptyset \rangle} + u_{\langle a,c|bd \rangle} \\
 &= (+2\delta_\emptyset - \delta_{\{a\}} - \delta_{\{c\}} - \delta_{\{d\}} + \delta_{\{c,d\}} - \delta_{\{b,c,d\}} + \delta_{\{a,b,c,d\}}) \\
 &\quad - (\delta_\emptyset - \delta_{\{a\}} - \delta_{\{b,d\}} + \delta_{\{a,b,d\}}) \\
 &= (+2\delta_\emptyset - \delta_{\{b\}} - \delta_{\{c\}} - \delta_{\{d\}} + \delta_{\{b,d\}} - \delta_{\{a,b,d\}} + \delta_{\{a,b,c,d\}}) \\
 &\quad - (\delta_\emptyset - \delta_{\{b\}} - \delta_{\{c,d\}} + \delta_{\{b,c,d\}}) \\
 &= (\delta_\emptyset - \delta_{\{d\}} - \delta_{\{b,c\}} + \delta_{\{b,d\}} - \delta_{\{a,b,d\}} + \delta_{\{a,b,c,d\}}) \\
 &\quad - (\delta_{\{c\}} - \delta_{\{b,c\}} - \delta_{\{c,d\}} + \delta_{\{b,c,d\}})
 \end{aligned}$$

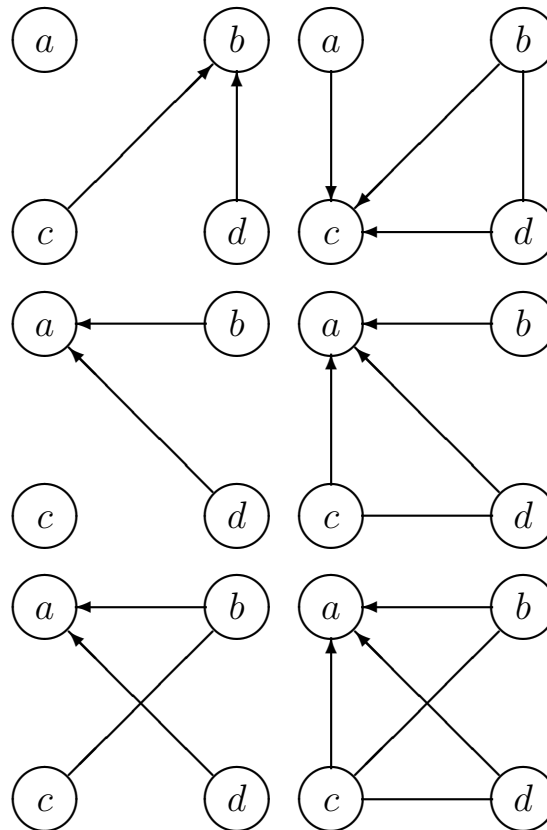

2.8.8.9 Differential inset (250)

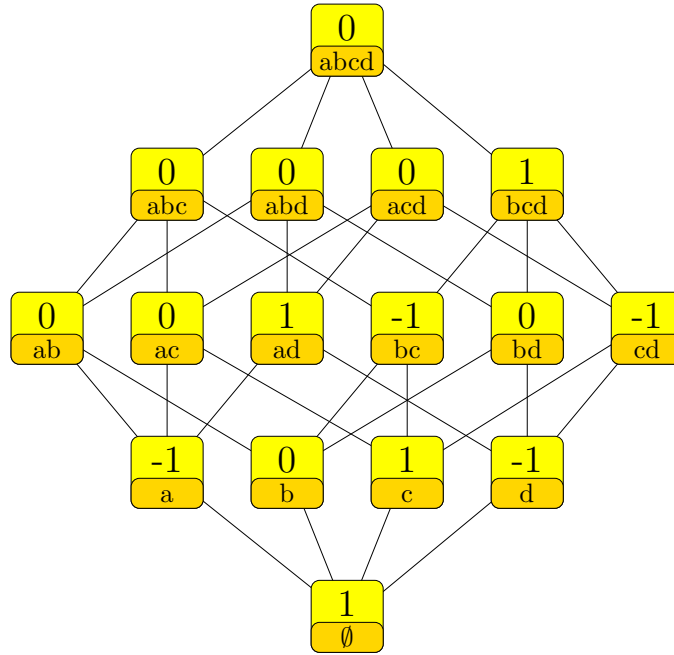

$$\begin{aligned}
 & \delta_{\emptyset} - \delta_{\{a\}} + \delta_{\{c\}} - \delta_{\{d\}} + \delta_{\{a,d\}} - \delta_{\{b,c\}} - \delta_{\{c,d\}} + \delta_{\{b,c,d\}} \\
 &= u_{\langle a,d|\emptyset \rangle} + u_{\langle b,d|c \rangle} \\
 &= (+2\delta_{\emptyset} - \delta_{\{a\}} - \delta_{\{d\}} - \delta_{\{b,c\}} + \delta_{\{a,b,c,d\}}) \\
 &\quad - (\delta_{\emptyset} - \delta_{\{c\}} - \delta_{\{a,d\}} + \delta_{\{c,d\}} - \delta_{\{b,c,d\}} + \delta_{\{a,b,c,d\}})
 \end{aligned}$$

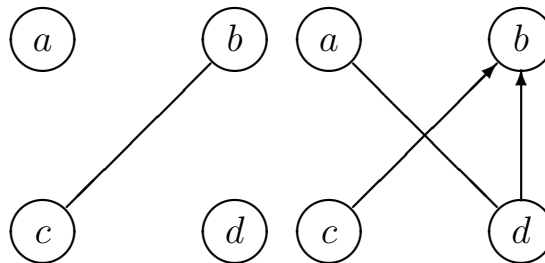

2.8.8.10 Differential imset (251)

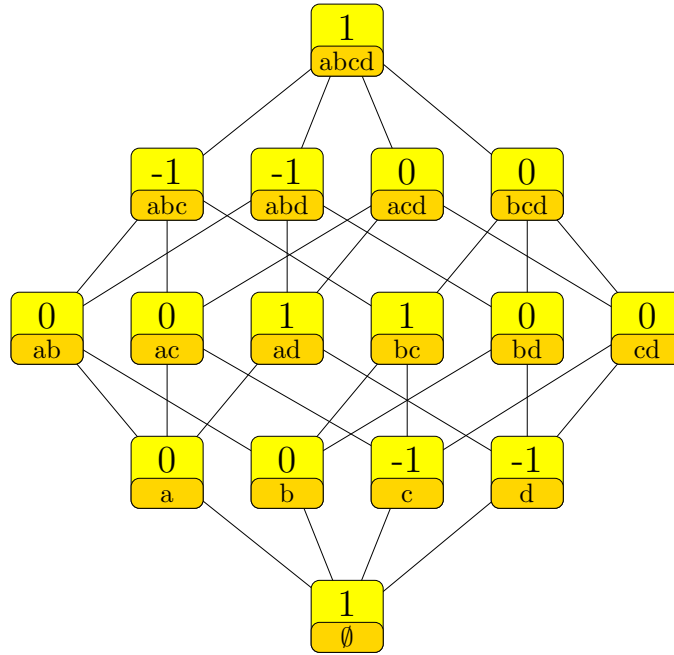

$$\begin{aligned}
 & \delta_\emptyset - \delta_{\{c\}} - \delta_{\{d\}} + \delta_{\{a,d\}} + \delta_{\{b,c\}} - \delta_{\{a,b,c\}} - \delta_{\{a,b,d\}} + \delta_{\{a,b,c,d\}} \\
 &= -u_{\langle a,b|\emptyset \rangle} + u_{\langle a,d|\emptyset \rangle} + u_{\langle b,c|\emptyset \rangle} + u_{\langle c,d|ab \rangle} \\
 &= (+2\delta_\emptyset - \delta_{\{a\}} - \delta_{\{c\}} - \delta_{\{d\}} + \delta_{\{a,d\}} - \delta_{\{a,b,d\}} + \delta_{\{a,b,c,d\}}) \\
 &\quad - (\delta_\emptyset - \delta_{\{a\}} - \delta_{\{b,c\}} + \delta_{\{a,b,c\}}) \\
 &= (\delta_\emptyset - \delta_{\{c\}} + \delta_{\{b,c\}} - \delta_{\{b,d\}} - \delta_{\{a,b,c\}} + \delta_{\{a,b,c,d\}}) \\
 &\quad - (\delta_{\{d\}} - \delta_{\{a,d\}} - \delta_{\{b,d\}} + \delta_{\{a,b,d\}})
 \end{aligned}$$

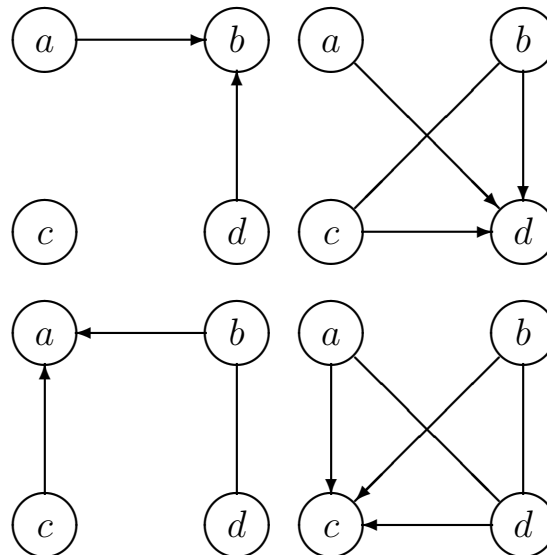

## 2.10 Squared Euclidean length 10

### 2.10.7 Number of nonzero values 7

#### 2.10.7.1 Differential imset (252)

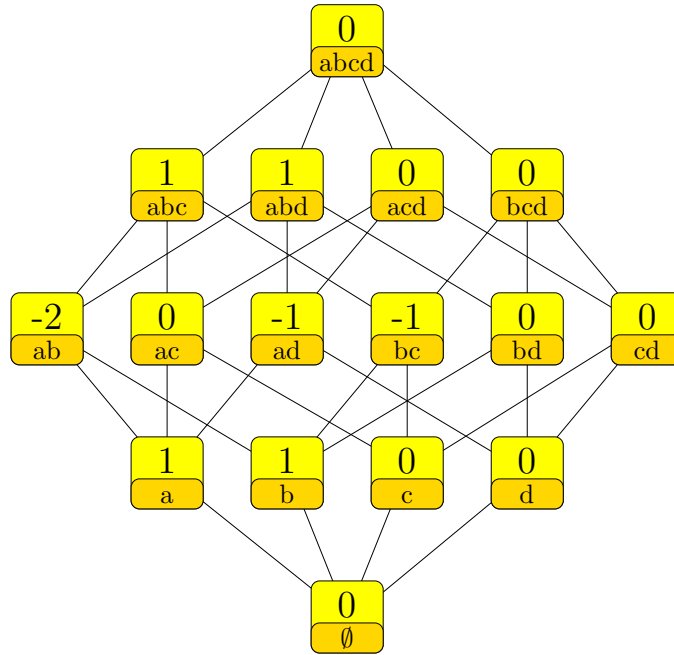

$$\begin{aligned}
 & \delta_{\{a\}} + \delta_{\{b\}} - 2\delta_{\{a,b\}} - \delta_{\{a,d\}} - \delta_{\{b,c\}} + \delta_{\{a,b,c\}} + \delta_{\{a,b,d\}} \\
 &= u_{\langle b,d|a \rangle} + u_{\langle a,c|b \rangle} \\
 &= (\delta_{\{a\}} + \delta_{\{b\}} - \delta_{\{a,b\}} - \delta_{\{a,d\}} - \delta_{\{b,c\}} + \delta_{\{a,b,c,d\}}) \\
 &\quad - (\delta_{\{a,b\}} - \delta_{\{a,b,c\}} - \delta_{\{a,b,d\}} + \delta_{\{a,b,c,d\}})
 \end{aligned}$$

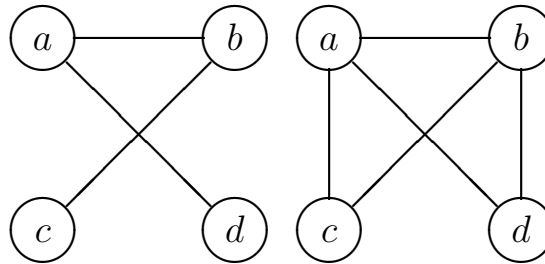

2.10.7.2 Differential imset (253)

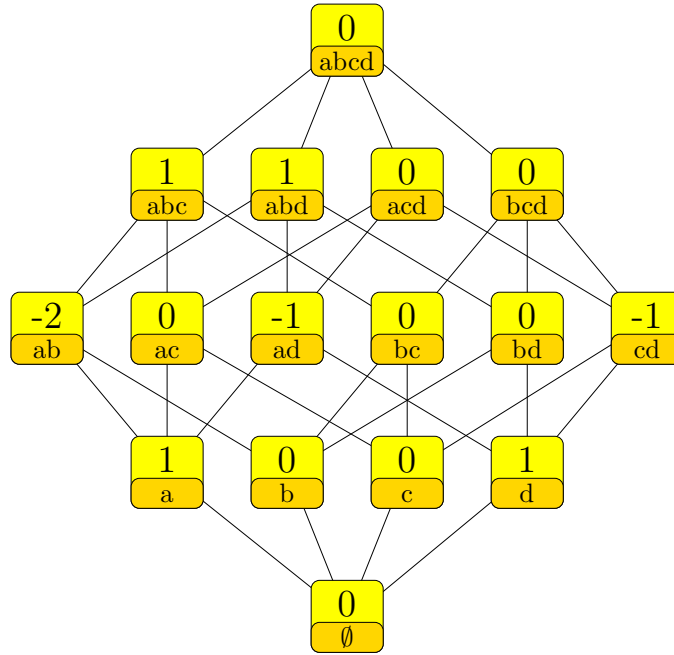

$$\begin{aligned}
 & \delta_{\{a\}} + \delta_{\{d\}} - 2\delta_{\{a,b\}} - \delta_{\{a,d\}} - \delta_{\{c,d\}} + \delta_{\{a,b,c\}} + \delta_{\{a,b,d\}} \\
 &= -u_{\langle c,d|ab \rangle} + u_{\langle b,d|ac \rangle} + u_{\langle b,c|a \rangle} + u_{\langle a,c|d \rangle} \\
 &= (\delta_{\emptyset} - \delta_{\{b\}} + \delta_{\{d\}} - \delta_{\{a,d\}} - \delta_{\{c,d\}} + \delta_{\{a,b,c,d\}}) \\
 &\quad - (\delta_{\emptyset} - \delta_{\{a\}} - \delta_{\{b\}} + 2\delta_{\{a,b\}} - \delta_{\{a,b,c\}} - \delta_{\{a,b,d\}} + \delta_{\{a,b,c,d\}})
 \end{aligned}$$

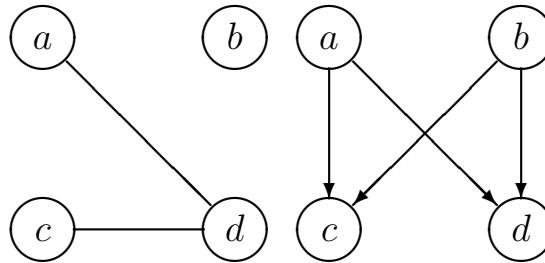



2.10.7.3 Differential imset (254)

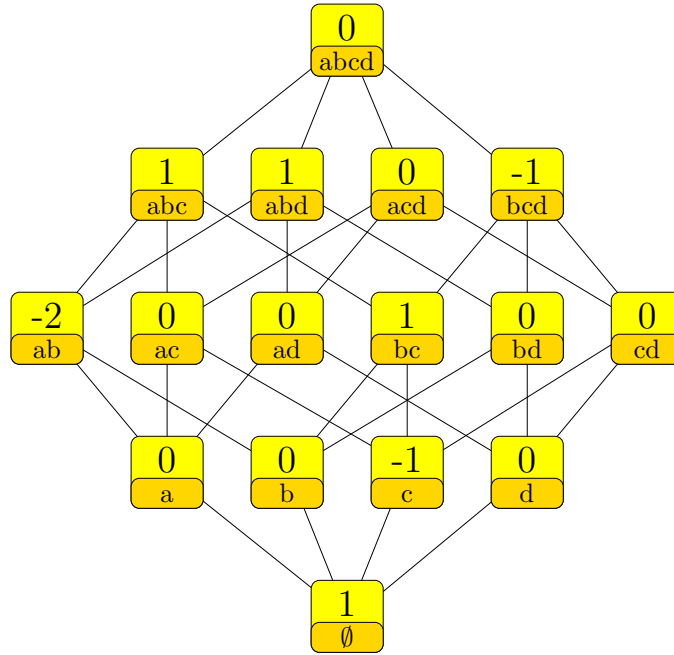

$$\begin{aligned}
 & \delta_{\emptyset} - \delta_{\{c\}} - 2\delta_{\{a,b\}} + \delta_{\{b,c\}} + \delta_{\{a,b,c\}} + \delta_{\{a,b,d\}} - \delta_{\{b,c,d\}} \\
 &= u_{\langle a,c|\emptyset \rangle} - u_{\langle c,d|ab \rangle} + u_{\langle a,d|bc \rangle} + u_{\langle b,c|a \rangle} \\
 &= (\delta_{\emptyset} - \delta_{\{c\}} - \delta_{\{a,b\}} + \delta_{\{b,c\}} - \delta_{\{b,c,d\}} + \delta_{\{a,b,c,d\}}) \\
 &\quad - (\delta_{\{a,b\}} - \delta_{\{a,b,c\}} - \delta_{\{a,b,d\}} + \delta_{\{a,b,c,d\}})
 \end{aligned}$$

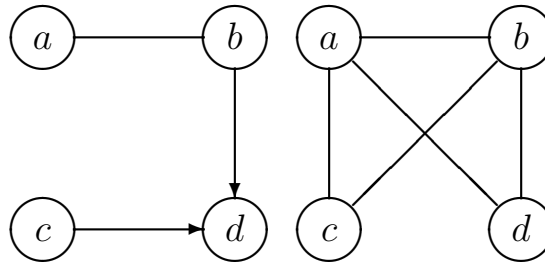

2.10.7.4 Differential imset (255)

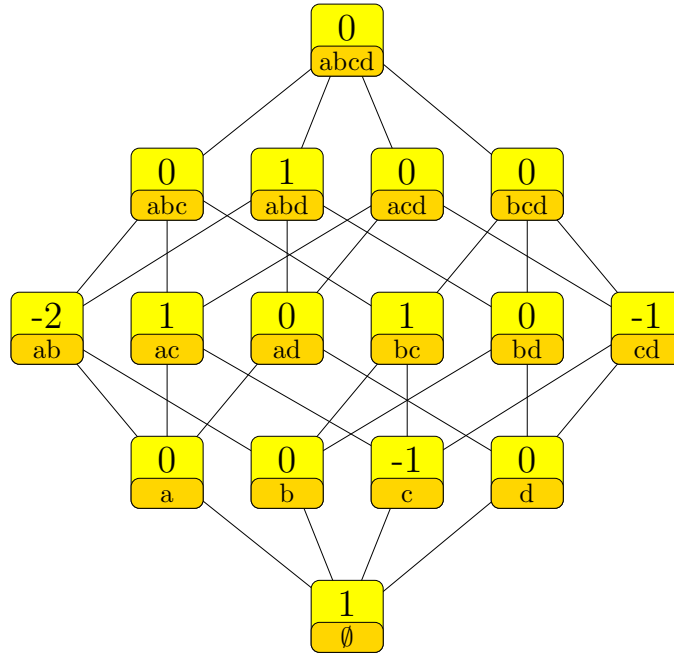

$$\begin{aligned}
 & \delta_\emptyset - \delta_{\{c\}} - 2\delta_{\{a,b\}} + \delta_{\{a,c\}} + \delta_{\{b,c\}} - \delta_{\{c,d\}} + \delta_{\{a,b,d\}} \\
 &= u_{\langle a,c|\emptyset \rangle} - u_{\langle c,d|ab \rangle} + u_{\langle b,d|ac \rangle} + u_{\langle b,c|a \rangle} - u_{\langle a,b|c \rangle} + u_{\langle a,d|c \rangle} \\
 &= (\delta_\emptyset - \delta_{\{a,b\}} - \delta_{\{c,d\}} + \delta_{\{a,b,c,d\}}) \\
 &\quad - (\delta_{\{c\}} + \delta_{\{a,b\}} - \delta_{\{a,c\}} - \delta_{\{b,c\}} - \delta_{\{a,b,d\}} + \delta_{\{a,b,c,d\}})
 \end{aligned}$$

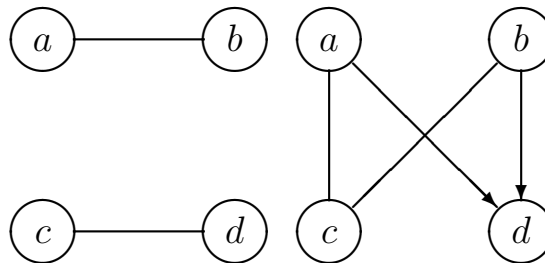

2.10.7.5 Differential imset (256)

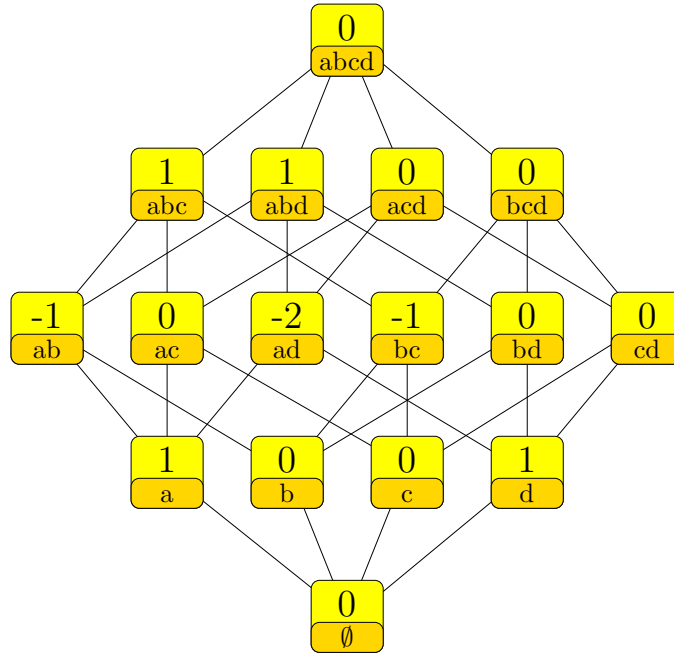

$$\begin{aligned}
 & \delta_{\{a\}} + \delta_{\{d\}} - \delta_{\{a,b\}} - 2\delta_{\{a,d\}} - \delta_{\{b,c\}} + \delta_{\{a,b,c\}} + \delta_{\{a,b,d\}} \\
 &= u_{\langle a,b|\emptyset \rangle} - u_{\langle a,d|\emptyset \rangle} + u_{\langle b,d|a \rangle} + u_{\langle a,c|b \rangle} \\
 &= (\delta_{\emptyset} - \delta_{\{a,d\}} - \delta_{\{b,c\}} + \delta_{\{a,b,c,d\}}) \\
 &\quad - (\delta_{\emptyset} - \delta_{\{a\}} - \delta_{\{d\}} + \delta_{\{a,b\}} + \delta_{\{a,d\}} - \delta_{\{a,b,c\}} - \delta_{\{a,b,d\}} + \delta_{\{a,b,c,d\}})
 \end{aligned}$$

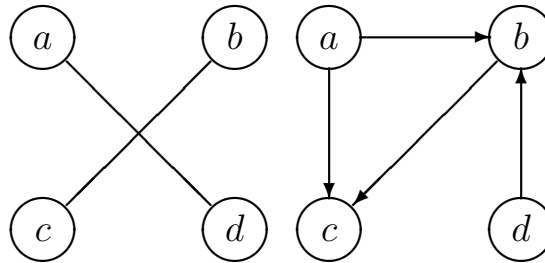

2.10.7.6 Differential imset (257)

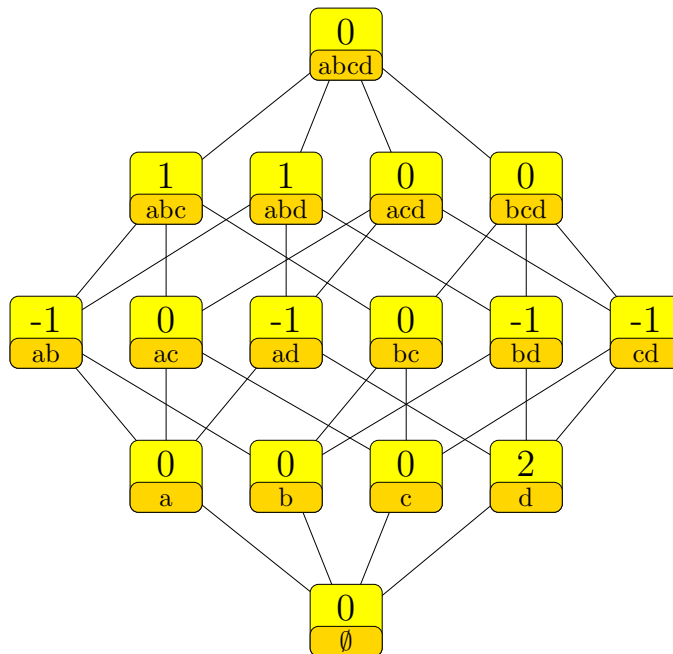

$$\begin{aligned}
 &+2\delta_{\{d\}} - \delta_{\{a,b\}} - \delta_{\{a,d\}} - \delta_{\{b,d\}} - \delta_{\{c,d\}} + \delta_{\{a,b,c\}} + \delta_{\{a,b,d\}} \\
 &= u_{\langle a,c|\emptyset \rangle} - u_{\langle c,d|\emptyset \rangle} + u_{\langle b,c|a \rangle} + u_{\langle a,b|d \rangle} \\
 &= (\delta_{\emptyset} - \delta_{\{b\}} + \delta_{\{d\}} - \delta_{\{a,d\}} - \delta_{\{c,d\}} + \delta_{\{a,b,c,d\}}) \\
 &\quad - (\delta_{\emptyset} - \delta_{\{b\}} - \delta_{\{d\}} + \delta_{\{a,b\}} + \delta_{\{b,d\}} - \delta_{\{a,b,c\}} - \delta_{\{a,b,d\}} + \delta_{\{a,b,c,d\}})
 \end{aligned}$$

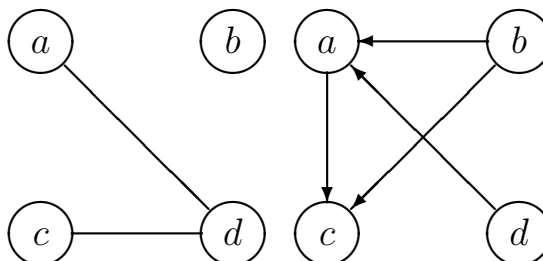

2.10.7.7 Differential imset (258)

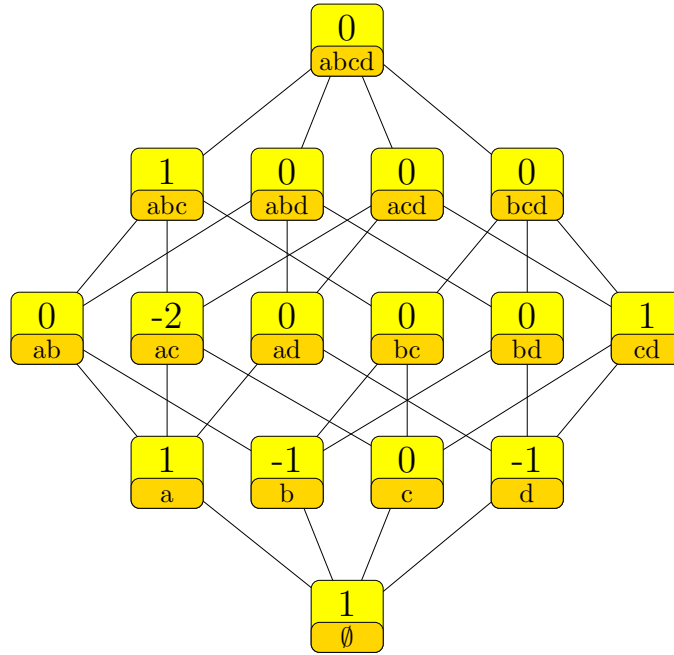

$$\begin{aligned}
 & \delta_{\emptyset} + \delta_{\{a\}} - \delta_{\{b\}} - \delta_{\{d\}} - 2\delta_{\{a,c\}} + \delta_{\{c,d\}} + \delta_{\{a,b,c\}} \\
 &= u_{\langle a,b|\emptyset \rangle} - u_{\langle a,c|\emptyset \rangle} + u_{\langle c,d|\emptyset \rangle} + u_{\langle b,c|a \rangle} \\
 &= (\delta_{\emptyset} + \delta_{\{a\}} - \delta_{\{b\}} - \delta_{\{a,c\}} - \delta_{\{a,d\}} + \delta_{\{a,b,c,d\}}) \\
 &\quad - (\delta_{\{d\}} + \delta_{\{a,c\}} - \delta_{\{a,d\}} - \delta_{\{c,d\}} - \delta_{\{a,b,c\}} + \delta_{\{a,b,c,d\}})
 \end{aligned}$$

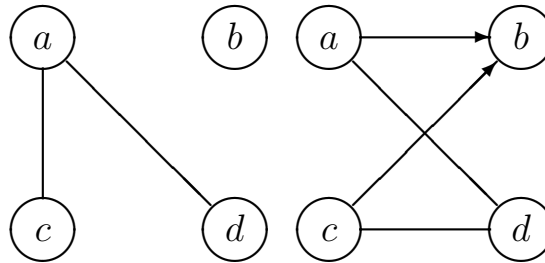

2.10.7.8 Differential imset (259)

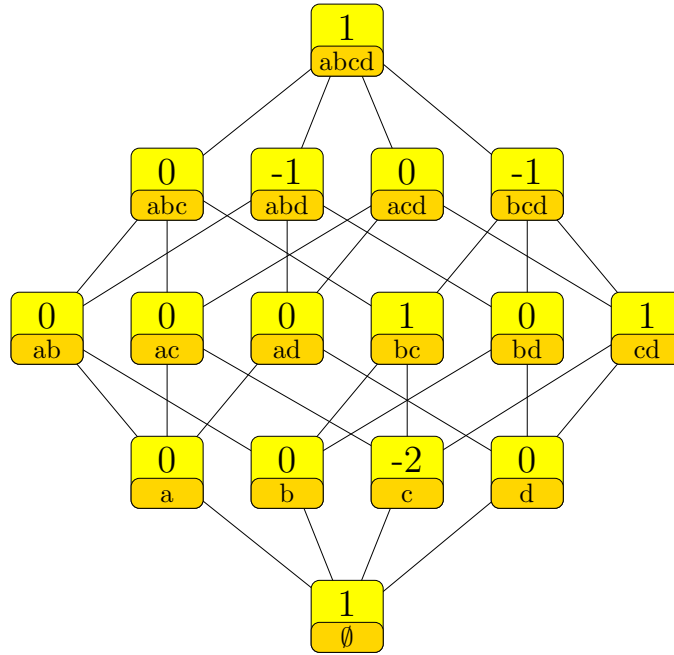

$$\begin{aligned}
 & \delta_{\emptyset} - 2\delta_{\{c\}} + \delta_{\{b,c\}} + \delta_{\{c,d\}} - \delta_{\{a,b,d\}} - \delta_{\{b,c,d\}} + \delta_{\{a,b,c,d\}} \\
 &= u_{\langle a,c|\emptyset \rangle} + u_{\langle c,d|ab \rangle} + u_{\langle b,c|a \rangle} - u_{\langle b,d|c \rangle} \\
 &= (\delta_{\emptyset} - \delta_{\{c\}} - \delta_{\{a,b,d\}} + \delta_{\{a,b,c,d\}}) \\
 &\quad - (\delta_{\{c\}} - \delta_{\{b,c\}} - \delta_{\{c,d\}} + \delta_{\{b,c,d\}})
 \end{aligned}$$

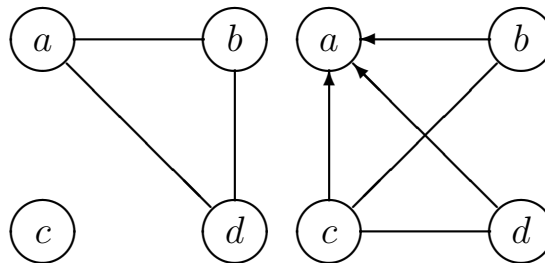

2.10.7.9 Differential imset (260)

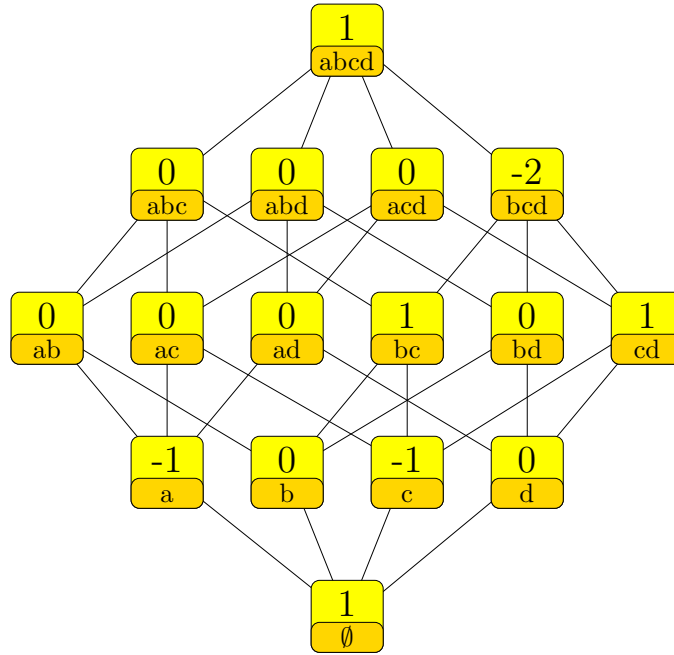

$$\begin{aligned}
 &\delta_\emptyset - \delta_{\{a\}} - \delta_{\{c\}} + \delta_{\{b,c\}} + \delta_{\{c,d\}} - 2\delta_{\{b,c,d\}} + \delta_{\{a,b,c,d\}} \\
 &= u_{\langle a,c|\emptyset \rangle} - u_{\langle b,d|ac \rangle} + u_{\langle a,d|bc \rangle} + u_{\langle a,b|cd \rangle} \\
 &= (+2\delta_\emptyset - \delta_{\{a\}} - \delta_{\{b\}} - \delta_{\{c\}} + \delta_{\{b,c\}} - \delta_{\{b,c,d\}} + \delta_{\{a,b,c,d\}}) \\
 &\quad - (\delta_\emptyset - \delta_{\{b\}} - \delta_{\{c,d\}} + \delta_{\{b,c,d\}})
 \end{aligned}$$

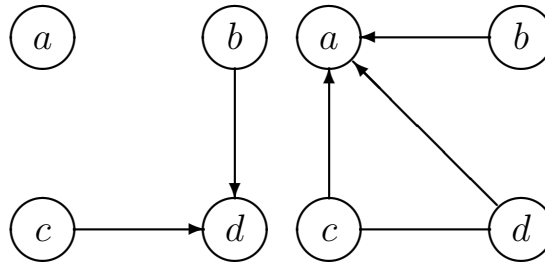

2.10.7.10 Differential imset (261)

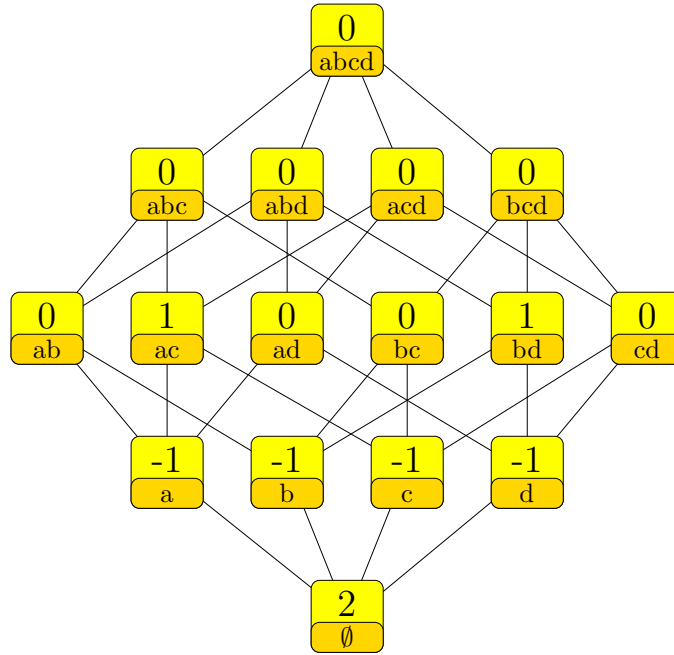

$$\begin{aligned}
 &+2\delta_\emptyset - \delta_{\{a\}} - \delta_{\{b\}} - \delta_{\{c\}} - \delta_{\{d\}} + \delta_{\{a,c\}} + \delta_{\{b,d\}} \\
 &= u_{\langle a,c|\emptyset \rangle} + u_{\langle b,d|\emptyset \rangle} \\
 &= (+2\delta_\emptyset - \delta_{\{b\}} - \delta_{\{c\}} - \delta_{\{a,d\}} + \delta_{\{a,b,c,d\}}) \\
 &\quad - (\delta_{\{a\}} + \delta_{\{d\}} - \delta_{\{a,c\}} - \delta_{\{a,d\}} - \delta_{\{b,d\}} + \delta_{\{a,b,c,d\}}) \\
 &= (+2\delta_\emptyset - \delta_{\{a\}} - \delta_{\{b\}} - \delta_{\{c,d\}} + \delta_{\{a,b,c,d\}}) \\
 &\quad - (\delta_{\{c\}} + \delta_{\{d\}} - \delta_{\{a,c\}} - \delta_{\{b,d\}} - \delta_{\{c,d\}} + \delta_{\{a,b,c,d\}})
 \end{aligned}$$

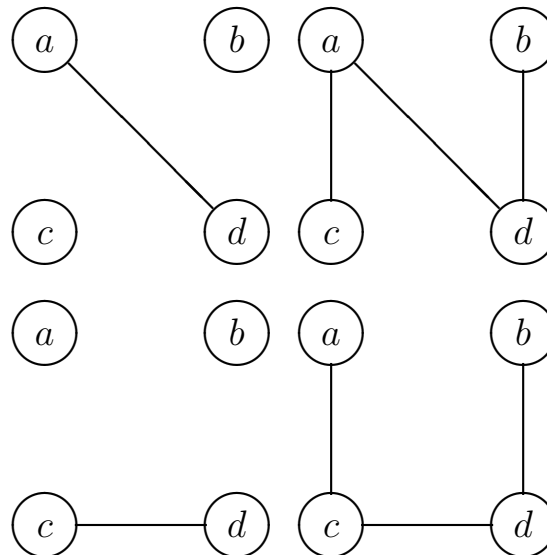



2.10.7.11 Differential imset (262)

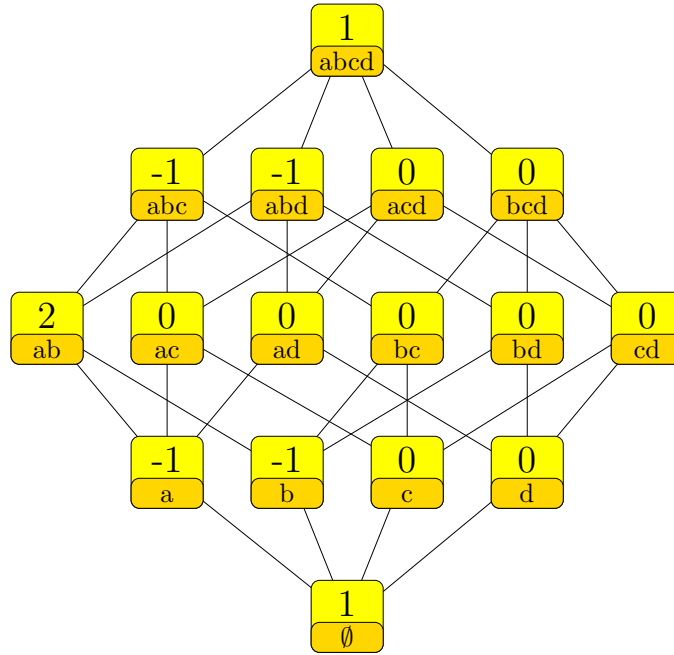

$$\begin{aligned}
 & \delta_\emptyset - \delta_{\{a\}} - \delta_{\{b\}} + 2\delta_{\{a,b\}} - \delta_{\{a,b,c\}} - \delta_{\{a,b,d\}} + \delta_{\{a,b,c,d\}} \\
 &= u_{\langle a,b|\emptyset \rangle} + u_{\langle c,d|ab \rangle} \\
 &= (+2\delta_\emptyset - \delta_{\{a\}} - \delta_{\{b\}} - \delta_{\{d\}} + \delta_{\{a,b\}} - \delta_{\{a,b,c\}} + \delta_{\{a,b,c,d\}}) \\
 &\quad - (\delta_\emptyset - \delta_{\{d\}} - \delta_{\{a,b\}} + \delta_{\{a,b,d\}})
 \end{aligned}$$

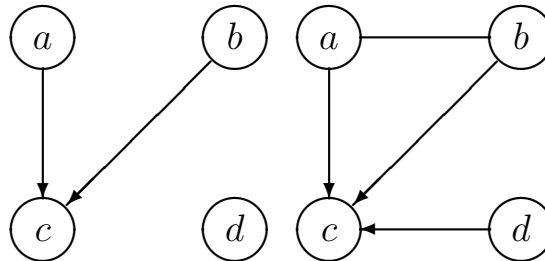

2.10.10 Number of nonzero values 10

2.10.10.1 Differential imset (263)

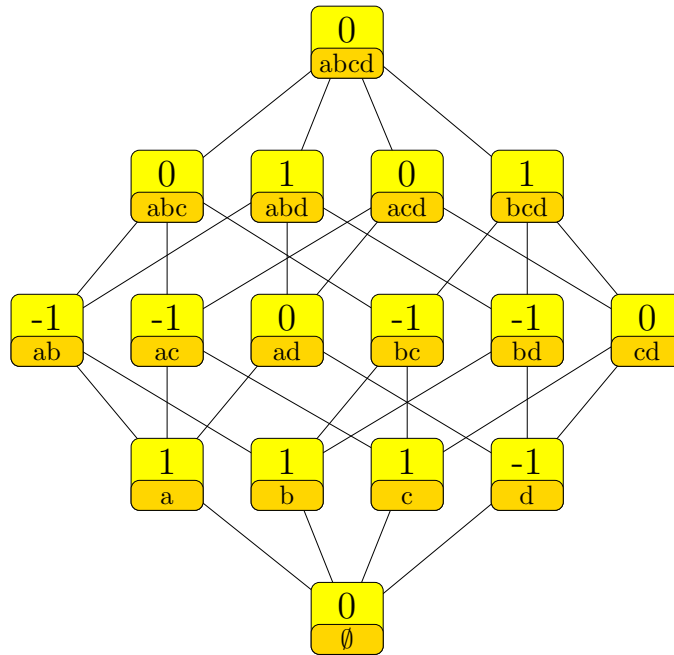

$$\begin{aligned}
 & \delta_{\{a\}} + \delta_{\{b\}} + \delta_{\{c\}} - \delta_{\{d\}} - \delta_{\{a,b\}} - \delta_{\{a,c\}} - \delta_{\{b,c\}} - \delta_{\{b,d\}} + \delta_{\{a,b,d\}} + \delta_{\{b,c,d\}} \\
 &= -u_{\langle a,c|\emptyset \rangle} + u_{\langle a,d|\emptyset \rangle} + u_{\langle b,d|a \rangle} + u_{\langle c,d|b \rangle} \\
 &= (\delta_{\emptyset} + \delta_{\{c\}} - \delta_{\{d\}} - \delta_{\{a,c\}} - \delta_{\{b,c\}} + \delta_{\{a,b,c,d\}}) \\
 &\quad - (\delta_{\emptyset} - \delta_{\{a\}} - \delta_{\{b\}} + \delta_{\{a,b\}} + \delta_{\{b,d\}} - \delta_{\{a,b,d\}} - \delta_{\{b,c,d\}} + \delta_{\{a,b,c,d\}})
 \end{aligned}$$

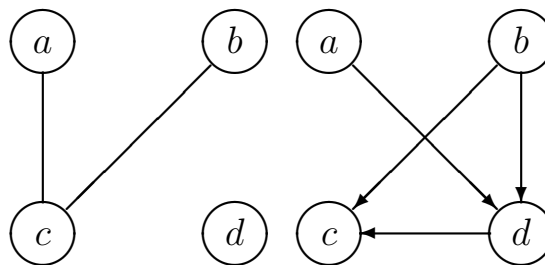

2.10.10.2 Differential imset (264)

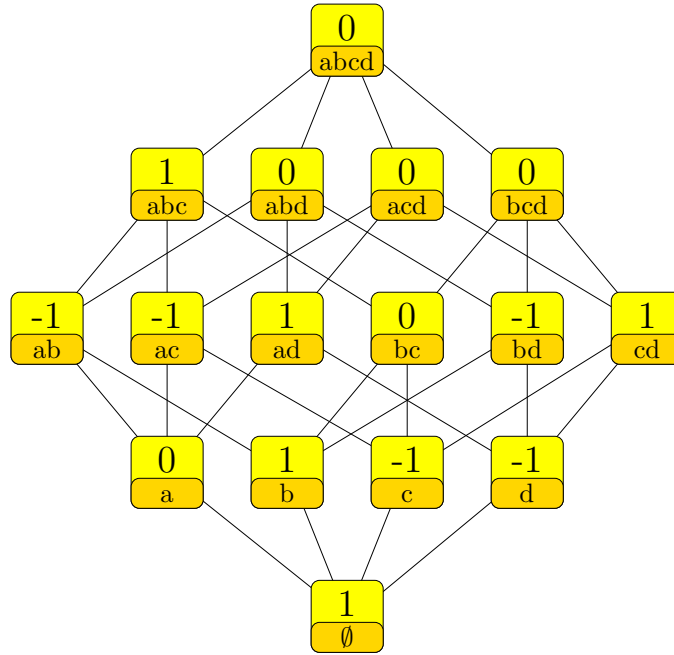

$$\begin{aligned}
 & \delta_\emptyset + \delta_{\{b\}} - \delta_{\{c\}} - \delta_{\{d\}} - \delta_{\{a,b\}} - \delta_{\{a,c\}} + \delta_{\{a,d\}} - \delta_{\{b,d\}} + \delta_{\{c,d\}} + \delta_{\{a,b,c\}} \\
 &= u_{\langle a,d|\emptyset \rangle} - u_{\langle b,d|\emptyset \rangle} + u_{\langle c,d|\emptyset \rangle} + u_{\langle b,c|a \rangle} \\
 &= (\delta_\emptyset + \delta_{\{b\}} - \delta_{\{c\}} - \delta_{\{a,b\}} - \delta_{\{b,d\}} + \delta_{\{a,b,c,d\}}) \\
 &\quad - (\delta_{\{d\}} + \delta_{\{a,c\}} - \delta_{\{a,d\}} - \delta_{\{c,d\}} - \delta_{\{a,b,c\}} + \delta_{\{a,b,c,d\}})
 \end{aligned}$$

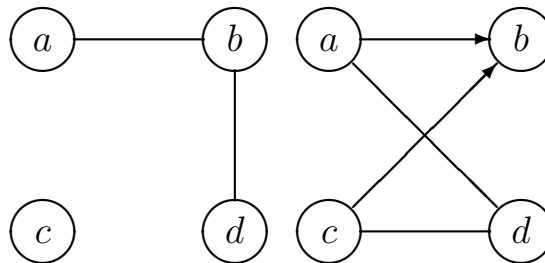

2.10.10.3 Differential imset (265)

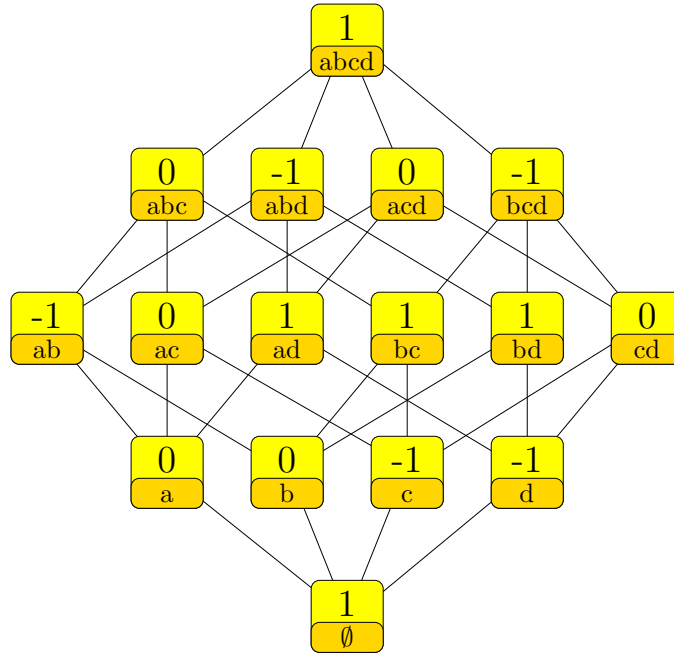

$$\begin{aligned}
 & \delta_{\emptyset} - \delta_{\{c\}} - \delta_{\{d\}} - \delta_{\{a,b\}} + \delta_{\{a,d\}} + \delta_{\{b,c\}} + \delta_{\{b,d\}} - \delta_{\{a,b,d\}} - \delta_{\{b,c,d\}} + \delta_{\{a,b,c,d\}} \\
 &= u_{\langle a,c|\emptyset \rangle} + u_{\langle a,d|bc \rangle} + u_{\langle b,c|a \rangle} - u_{\langle a,b|d \rangle} \\
 &= (\delta_{\emptyset} - \delta_{\{c\}} - \delta_{\{a,b\}} + \delta_{\{b,c\}} - \delta_{\{b,c,d\}} + \delta_{\{a,b,c,d\}}) \\
 &\quad - (\delta_{\{d\}} - \delta_{\{a,d\}} - \delta_{\{b,d\}} + \delta_{\{a,b,d\}})
 \end{aligned}$$

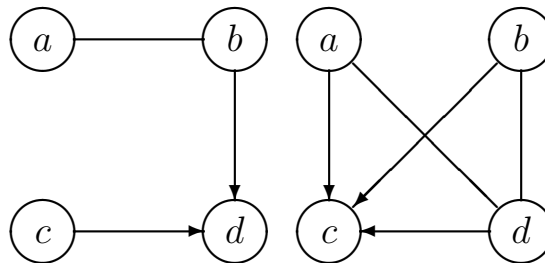

2.10.10.4 Differential imset (266)

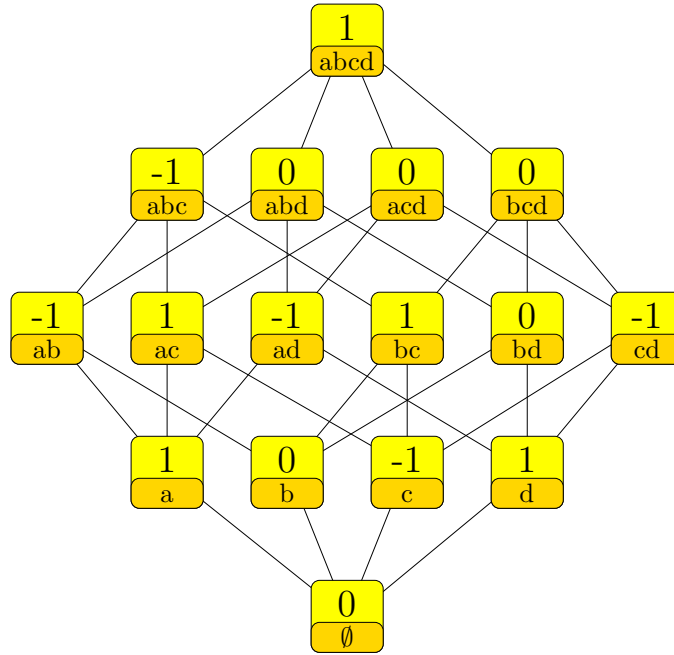

$$\begin{aligned}
 & \delta_{\{a\}} - \delta_{\{c\}} + \delta_{\{d\}} - \delta_{\{a,b\}} + \delta_{\{a,c\}} - \delta_{\{a,d\}} + \delta_{\{b,c\}} - \delta_{\{c,d\}} - \delta_{\{a,b,c\}} + \delta_{\{a,b,c,d\}} \\
 &= u_{\langle b,d|ac \rangle} + u_{\langle b,c|a \rangle} - u_{\langle a,b|c \rangle} + u_{\langle a,c|d \rangle} \\
 &= (\delta_{\{a\}} + \delta_{\{d\}} - \delta_{\{a,b\}} - \delta_{\{a,d\}} - \delta_{\{c,d\}} + \delta_{\{a,b,c,d\}}) \\
 &\quad - (\delta_{\{c\}} - \delta_{\{a,c\}} - \delta_{\{b,c\}} + \delta_{\{a,b,c\}})
 \end{aligned}$$

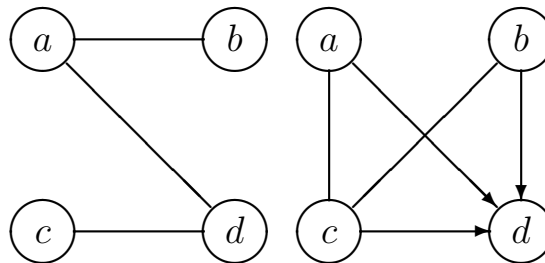

2.10.10.5 Differential imset (267)

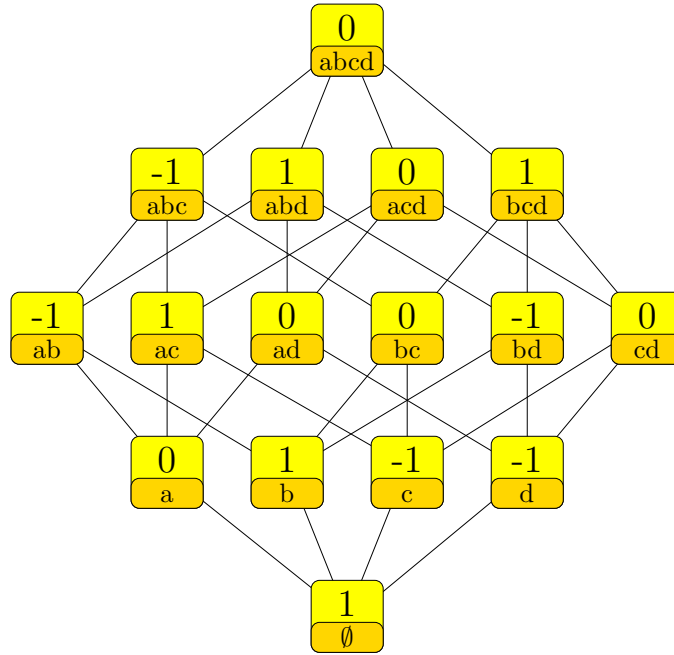

$$\begin{aligned}
 & \delta_\emptyset + \delta_{\{b\}} - \delta_{\{c\}} - \delta_{\{d\}} - \delta_{\{a,b\}} + \delta_{\{a,c\}} - \delta_{\{b,d\}} - \delta_{\{a,b,c\}} + \delta_{\{a,b,d\}} + \delta_{\{b,c,d\}} \\
 &= u_{\langle a,d|\emptyset \rangle} + u_{\langle b,d|a \rangle} - u_{\langle a,b|c \rangle} + u_{\langle c,d|b \rangle} \\
 &= (+2\delta_\emptyset - \delta_{\{a\}} - \delta_{\{c\}} - \delta_{\{d\}} + \delta_{\{a,c\}} - \delta_{\{a,b,c\}} + \delta_{\{a,b,c,d\}}) \\
 &\quad - (\delta_\emptyset - \delta_{\{a\}} - \delta_{\{b\}} + \delta_{\{a,b\}} + \delta_{\{b,d\}} - \delta_{\{a,b,d\}} - \delta_{\{b,c,d\}} + \delta_{\{a,b,c,d\}})
 \end{aligned}$$

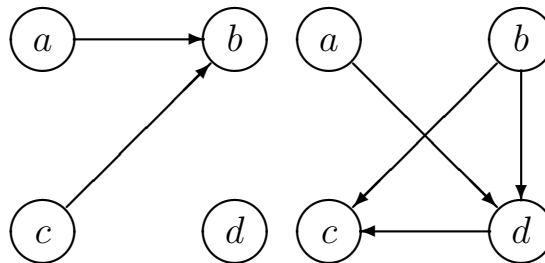

2.10.10.6 Differential imset (268)

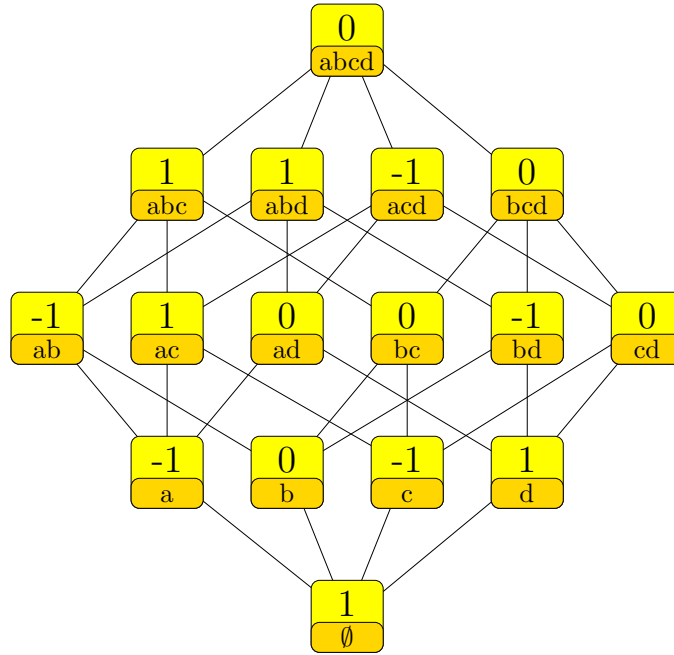

$$\begin{aligned}
 &\delta_\emptyset - \delta_{\{a\}} - \delta_{\{c\}} + \delta_{\{d\}} - \delta_{\{a,b\}} + \delta_{\{a,c\}} - \delta_{\{b,d\}} + \delta_{\{a,b,c\}} + \delta_{\{a,b,d\}} - \delta_{\{a,c,d\}} \\
 &= u_{\langle a,c|\emptyset \rangle} - u_{\langle c,d|ab \rangle} + u_{\langle b,c|ad \rangle} + u_{\langle a,b|d \rangle} \\
 &= (+2\delta_\emptyset - \delta_{\{a\}} - \delta_{\{b\}} - \delta_{\{c\}} + \delta_{\{a,c\}} - \delta_{\{a,c,d\}} + \delta_{\{a,b,c,d\}}) \\
 &\quad - (\delta_\emptyset - \delta_{\{b\}} - \delta_{\{d\}} + \delta_{\{a,b\}} + \delta_{\{b,d\}} - \delta_{\{a,b,c\}} - \delta_{\{a,b,d\}} + \delta_{\{a,b,c,d\}})
 \end{aligned}$$

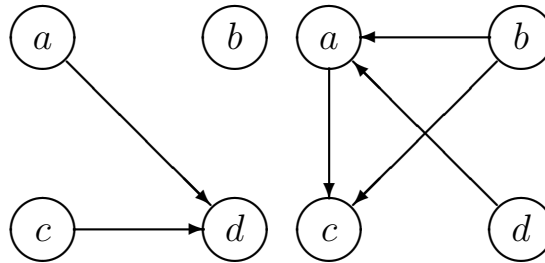

2.10.10.7 Differential imset (269)

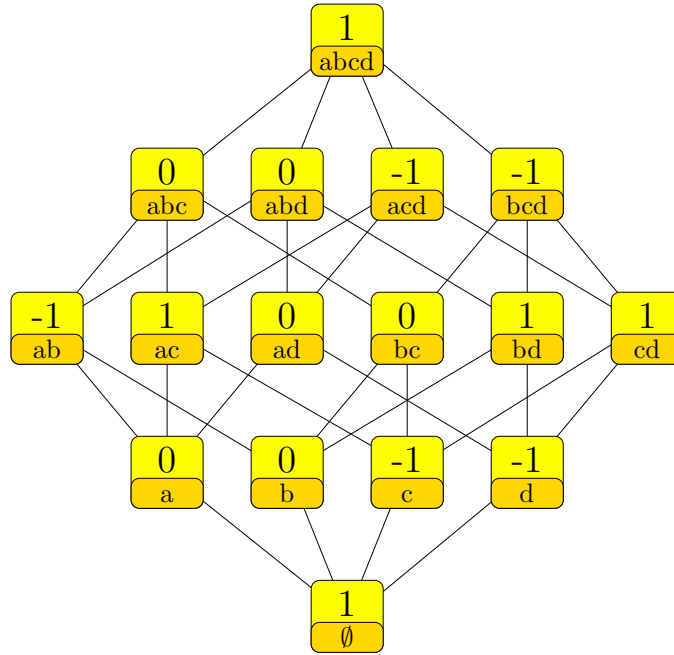

$$\begin{aligned}
 & \delta_{\emptyset} - \delta_{\{c\}} - \delta_{\{d\}} - \delta_{\{a,b\}} + \delta_{\{a,c\}} + \delta_{\{b,d\}} + \delta_{\{c,d\}} - \delta_{\{a,c,d\}} - \delta_{\{b,c,d\}} + \delta_{\{a,b,c,d\}} \\
 &= u_{\langle a,d|\emptyset \rangle} + u_{\langle a,c|bd \rangle} + u_{\langle b,d|a \rangle} - u_{\langle a,d|c \rangle} \\
 &= (\delta_{\emptyset} - \delta_{\{d\}} - \delta_{\{a,b\}} + \delta_{\{b,d\}} - \delta_{\{b,c,d\}} + \delta_{\{a,b,c,d\}}) \\
 &\quad - (\delta_{\{c\}} - \delta_{\{a,c\}} - \delta_{\{c,d\}} + \delta_{\{a,c,d\}})
 \end{aligned}$$

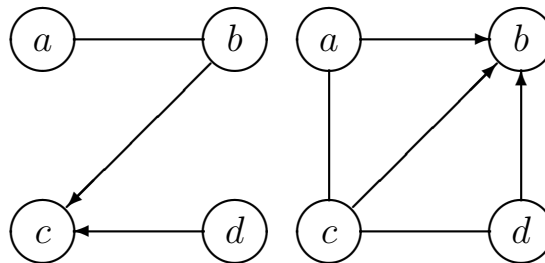



2.10.10.8 Differential imset (270)

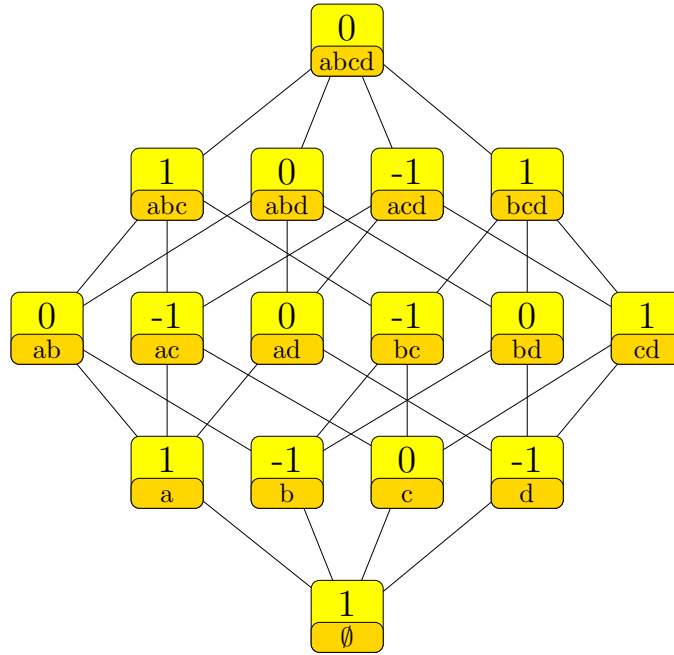

$$\begin{aligned}
 & \delta_\emptyset + \delta_{\{a\}} - \delta_{\{b\}} - \delta_{\{d\}} - \delta_{\{a,c\}} - \delta_{\{b,c\}} + \delta_{\{c,d\}} + \delta_{\{a,b,c\}} - \delta_{\{a,c,d\}} + \delta_{\{b,c,d\}} \\
 &= u_{\langle a,b|\emptyset \rangle} - u_{\langle a,c|\emptyset \rangle} + u_{\langle c,d|\emptyset \rangle} + u_{\langle b,d|ac \rangle} - u_{\langle a,d|bc \rangle} + u_{\langle b,c|a \rangle} \\
 &= (+2\delta_\emptyset - \delta_{\{b\}} - \delta_{\{c\}} - \delta_{\{d\}} + \delta_{\{c,d\}} - \delta_{\{a,c,d\}} + \delta_{\{a,b,c,d\}}) \\
 &\quad - (\delta_\emptyset - \delta_{\{a\}} - \delta_{\{c\}} + \delta_{\{a,c\}} + \delta_{\{b,c\}} - \delta_{\{a,b,c\}} - \delta_{\{b,c,d\}} + \delta_{\{a,b,c,d\}})
 \end{aligned}$$

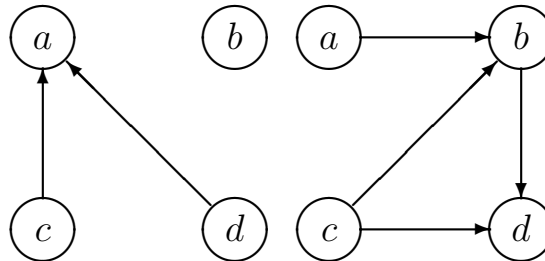

2.10.10.9 Differential imset (271)

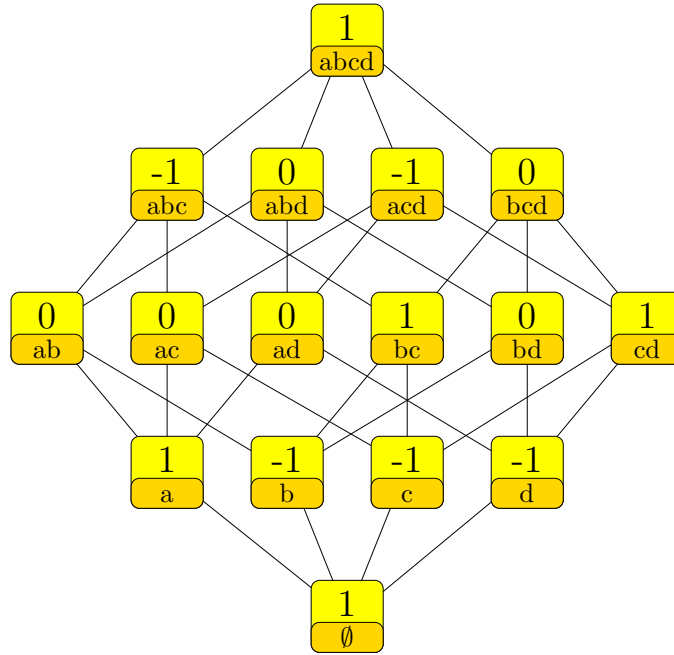

$$\begin{aligned}
 & \delta_\emptyset + \delta_{\{a\}} - \delta_{\{b\}} - \delta_{\{c\}} - \delta_{\{d\}} + \delta_{\{b,c\}} + \delta_{\{c,d\}} - \delta_{\{a,b,c\}} - \delta_{\{a,c,d\}} + \delta_{\{a,b,c,d\}} \\
 &= -u_{\langle a,c|\emptyset \rangle} + u_{\langle b,c|\emptyset \rangle} + u_{\langle c,d|\emptyset \rangle} + u_{\langle b,d|ac \rangle} \\
 &= (+2\delta_\emptyset - \delta_{\{b\}} - \delta_{\{c\}} - \delta_{\{d\}} + \delta_{\{b,c\}} - \delta_{\{a,b,c\}} + \delta_{\{a,b,c,d\}}) \\
 &\quad - (\delta_\emptyset - \delta_{\{a\}} - \delta_{\{c,d\}} + \delta_{\{a,c,d\}})
 \end{aligned}$$

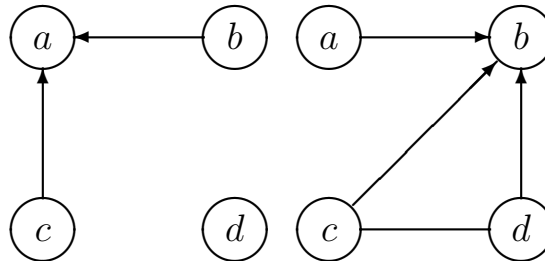

2.10.10.10 Differential imset (272)

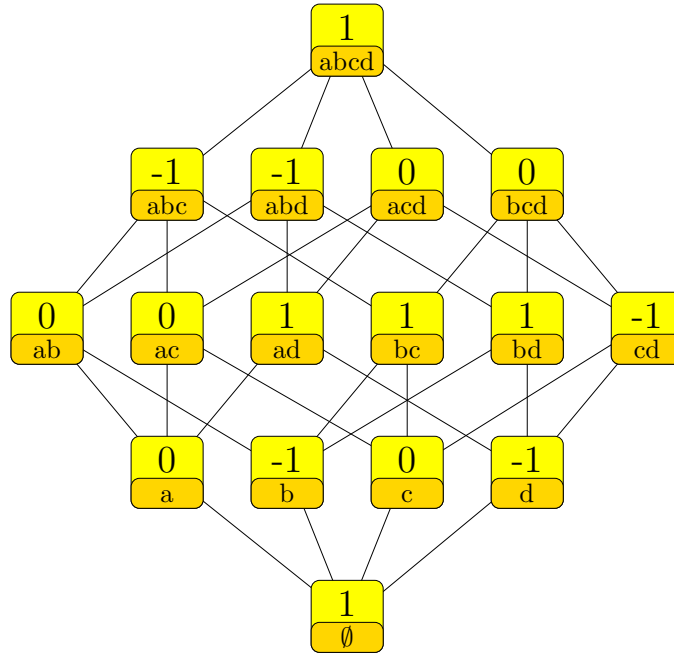

$$\begin{aligned}
 & \delta_{\emptyset} - \delta_{\{b\}} - \delta_{\{d\}} + \delta_{\{a,d\}} + \delta_{\{b,c\}} + \delta_{\{b,d\}} - \delta_{\{c,d\}} - \delta_{\{a,b,c\}} - \delta_{\{a,b,d\}} + \delta_{\{a,b,c,d\}} \\
 &= u_{\langle b,c|\emptyset \rangle} + u_{\langle b,d|ac \rangle} + u_{\langle a,d|c \rangle} - u_{\langle a,b|d \rangle} \\
 &= (\delta_{\emptyset} - \delta_{\{b\}} + \delta_{\{b,c\}} - \delta_{\{c,d\}} - \delta_{\{a,b,c\}} + \delta_{\{a,b,c,d\}}) \\
 &\quad - (\delta_{\{d\}} - \delta_{\{a,d\}} - \delta_{\{b,d\}} + \delta_{\{a,b,d\}})
 \end{aligned}$$

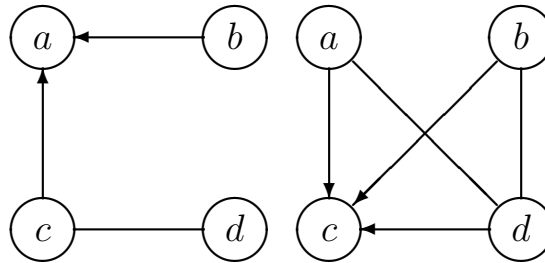

## 2.12 Squared Euclidean length 12

### 2.12.6 Number of nonzero values 6

#### 2.12.6.1 Differential imset (273)

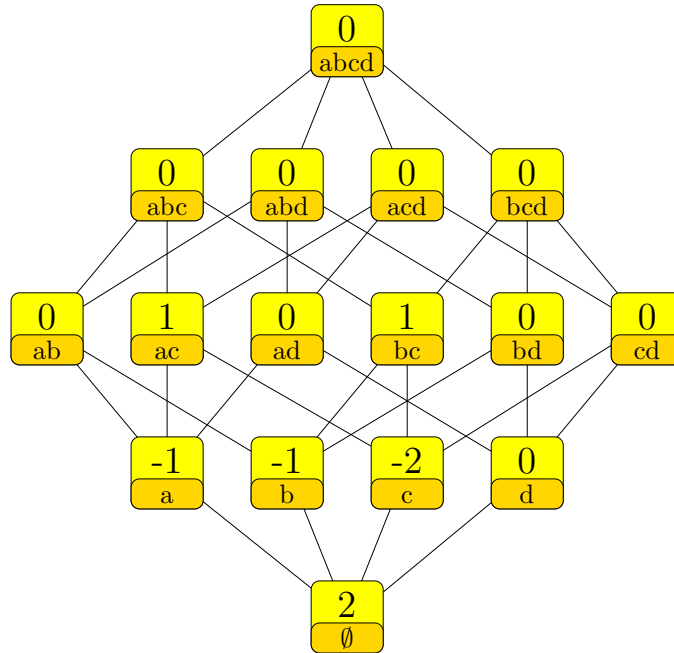

$$\begin{aligned}
 &+2\delta_\emptyset - \delta_{\{a\}} - \delta_{\{b\}} - 2\delta_{\{c\}} + \delta_{\{a,c\}} + \delta_{\{b,c\}} \\
 &= u_{\langle a,c|\emptyset \rangle} + u_{\langle b,c|\emptyset \rangle} \\
 &= (+2\delta_\emptyset - \delta_{\{a\}} - \delta_{\{c\}} - \delta_{\{b,d\}} + \delta_{\{a,b,c,d\}}) \\
 &\quad - (\delta_{\{b\}} + \delta_{\{c\}} - \delta_{\{a,c\}} - \delta_{\{b,c\}} - \delta_{\{b,d\}} + \delta_{\{a,b,c,d\}}) \\
 &= (+2\delta_\emptyset - \delta_{\{a\}} - \delta_{\{b\}} - \delta_{\{c\}} + \delta_{\{a,b,c\}}) \\
 &\quad - (\delta_{\{c\}} - \delta_{\{a,c\}} - \delta_{\{b,c\}} + \delta_{\{a,b,c\}})
 \end{aligned}$$

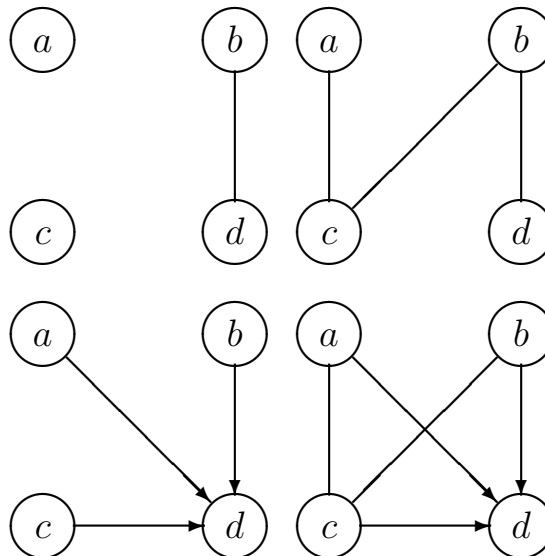

2.12.9 Number of nonzero values 9

2.12.9.1 Differential imset (274)

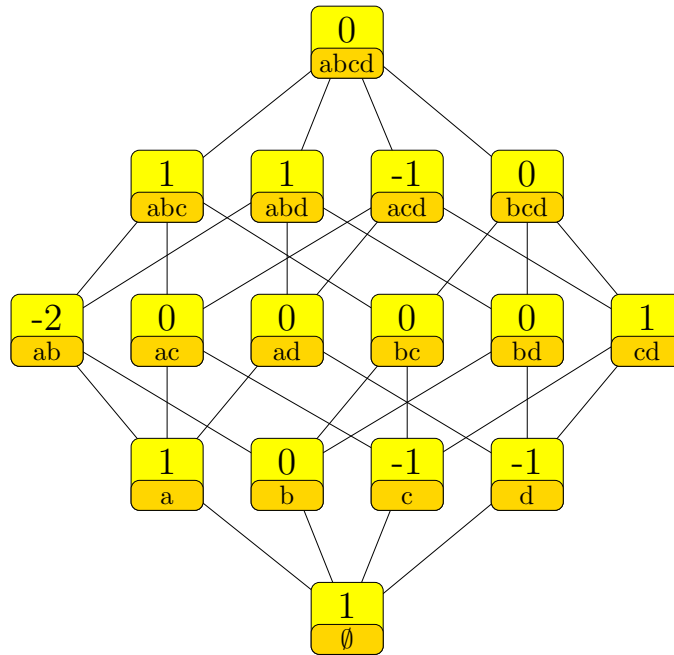

$$\begin{aligned}
 & \delta_\emptyset + \delta_{\{a\}} - \delta_{\{c\}} - \delta_{\{d\}} - 2\delta_{\{a,b\}} + \delta_{\{c,d\}} + \delta_{\{a,b,c\}} + \delta_{\{a,b,d\}} - \delta_{\{a,c,d\}} \\
 &= u_{\langle c,d|\emptyset \rangle} - u_{\langle c,d|ab \rangle} + u_{\langle b,d|ac \rangle} + u_{\langle b,c|a \rangle} \\
 &= (\delta_\emptyset + \delta_{\{a\}} - \delta_{\{c\}} - \delta_{\{d\}} - \delta_{\{a,b\}} + \delta_{\{c,d\}} - \delta_{\{a,c,d\}} + \delta_{\{a,b,c,d\}}) \\
 &\quad - (\delta_{\{a,b\}} - \delta_{\{a,b,c\}} - \delta_{\{a,b,d\}} + \delta_{\{a,b,c,d\}})
 \end{aligned}$$

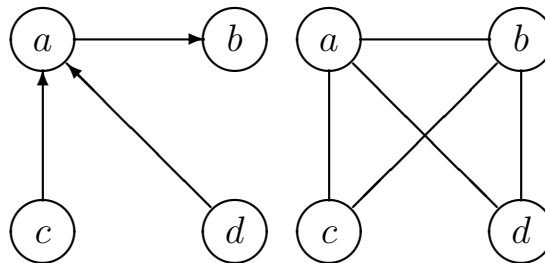

2.12.9.2 Differential imset (275)

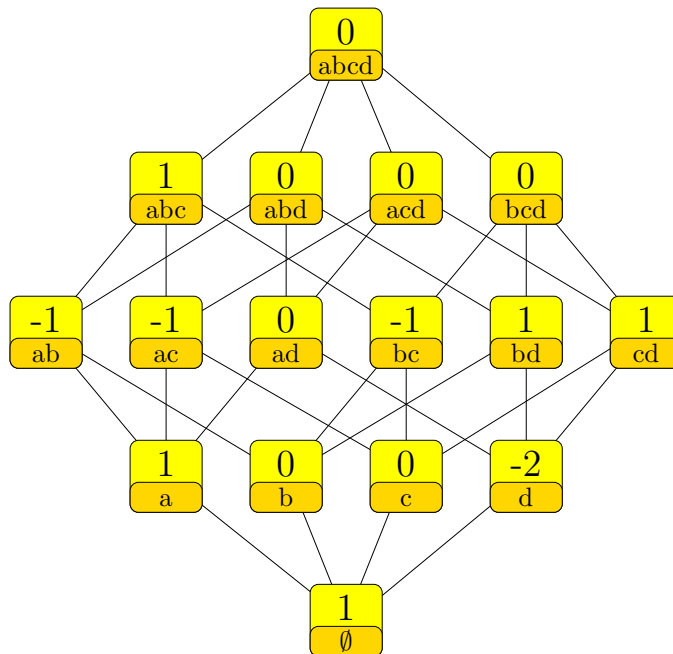

$$\begin{aligned}
 & \delta_\emptyset + \delta_{\{a\}} - 2\delta_{\{d\}} - \delta_{\{a,b\}} - \delta_{\{a,c\}} - \delta_{\{b,c\}} + \delta_{\{b,d\}} + \delta_{\{c,d\}} + \delta_{\{a,b,c\}} \\
 &= -u_{\langle a,c|\emptyset \rangle} + u_{\langle b,d|\emptyset \rangle} + u_{\langle c,d|\emptyset \rangle} + u_{\langle a,c|b \rangle} \\
 &= (\delta_\emptyset + \delta_{\{a\}} - \delta_{\{d\}} - \delta_{\{a,b\}} - \delta_{\{a,c\}} + \delta_{\{a,b,c,d\}}) \\
 &\quad - (\delta_{\{d\}} + \delta_{\{b,c\}} - \delta_{\{b,d\}} - \delta_{\{c,d\}} - \delta_{\{a,b,c\}} + \delta_{\{a,b,c,d\}})
 \end{aligned}$$

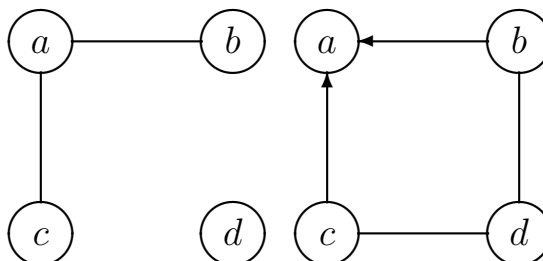

2.12.9.3 Differential imset (276)

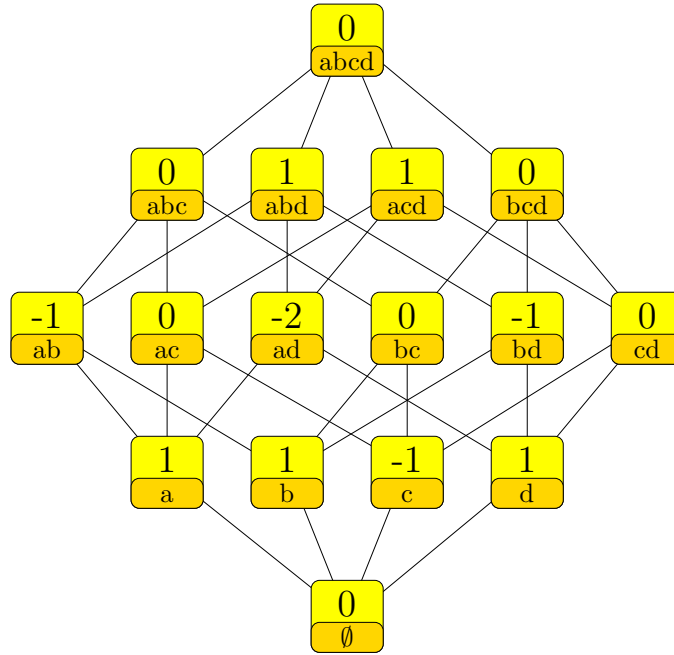

$$\begin{aligned}
 & \delta_{\{a\}} + \delta_{\{b\}} - \delta_{\{c\}} + \delta_{\{d\}} - \delta_{\{a,b\}} - 2\delta_{\{a,d\}} - \delta_{\{b,d\}} + \delta_{\{a,b,d\}} + \delta_{\{a,c,d\}} \\
 &= u_{\langle a,c|\emptyset \rangle} - u_{\langle a,d|\emptyset \rangle} + u_{\langle a,d|b \rangle} + u_{\langle c,d|a \rangle} \\
 &= (\delta_{\emptyset} + \delta_{\{b\}} - \delta_{\{c\}} - \delta_{\{a,b\}} - \delta_{\{b,d\}} + \delta_{\{a,b,c,d\}}) \\
 &\quad - (\delta_{\emptyset} - \delta_{\{a\}} - \delta_{\{d\}} + 2\delta_{\{a,d\}} - \delta_{\{a,b,d\}} - \delta_{\{a,c,d\}} + \delta_{\{a,b,c,d\}}) \\
 &= (\delta_{\emptyset} - \delta_{\{c\}} + \delta_{\{d\}} - \delta_{\{a,d\}} - \delta_{\{b,d\}} + \delta_{\{a,b,c,d\}}) \\
 &\quad - (\delta_{\emptyset} - \delta_{\{a\}} - \delta_{\{b\}} + \delta_{\{a,b\}} + \delta_{\{a,d\}} - \delta_{\{a,b,d\}} - \delta_{\{a,c,d\}} + \delta_{\{a,b,c,d\}})
 \end{aligned}$$

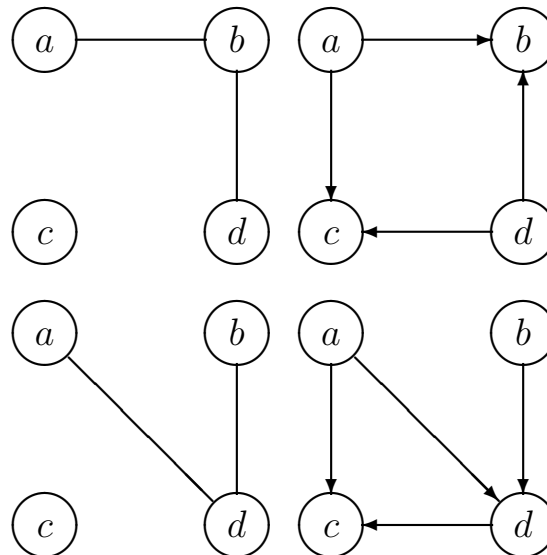

2.12.9.4 Differential imset (277)

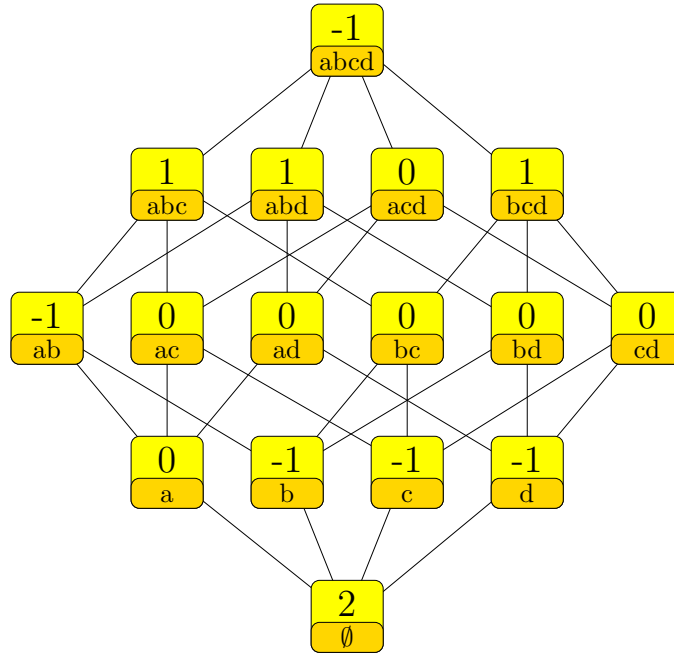

$$\begin{aligned}
 &+2\delta_\emptyset - \delta_{\{b\}} - \delta_{\{c\}} - \delta_{\{d\}} - \delta_{\{a,b\}} + \delta_{\{a,b,c\}} + \delta_{\{a,b,d\}} + \delta_{\{b,c,d\}} - \delta_{\{a,b,c,d\}} \\
 &= u_{\langle b,c|\emptyset\rangle} + u_{\langle b,d|\emptyset\rangle} - u_{\langle c,d|ab\rangle} + u_{\langle c,d|b\rangle} \\
 &= (+2\delta_\emptyset - \delta_{\{b\}} - \delta_{\{c\}} - \delta_{\{d\}} + \delta_{\{b,c,d\}}) \\
 &\quad - (\delta_{\{a,b\}} - \delta_{\{a,b,c\}} - \delta_{\{a,b,d\}} + \delta_{\{a,b,c,d\}})
 \end{aligned}$$

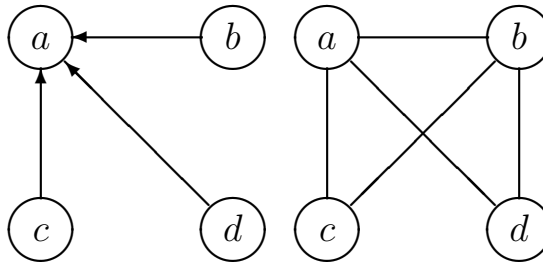



2.12.9.5 Differential imset (278)

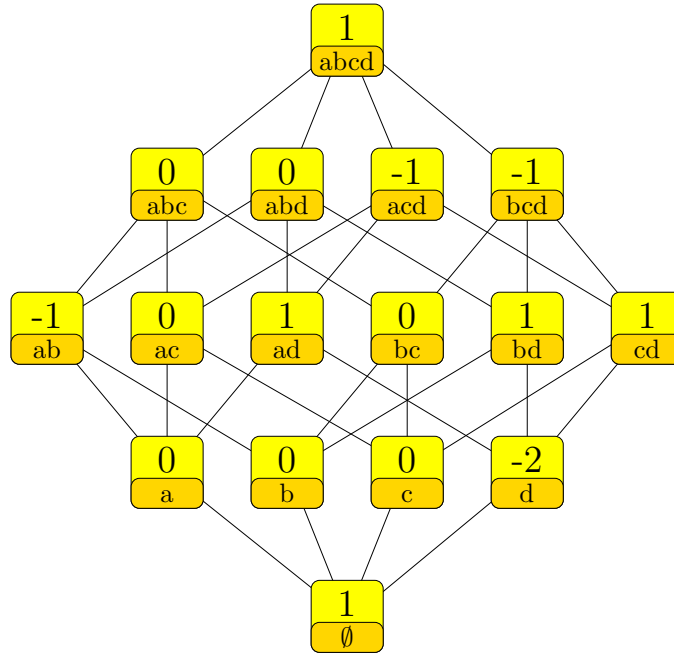

$$\begin{aligned}
 & \delta_{\emptyset} - 2\delta_{\{d\}} - \delta_{\{a,b\}} + \delta_{\{a,d\}} + \delta_{\{b,d\}} + \delta_{\{c,d\}} - \delta_{\{a,c,d\}} - \delta_{\{b,c,d\}} + \delta_{\{a,b,c,d\}} \\
 &= u_{\langle a,d|\emptyset \rangle} + u_{\langle a,c|bd \rangle} + u_{\langle b,d|a \rangle} - u_{\langle a,c|d \rangle} \\
 &= (\delta_{\emptyset} - \delta_{\{d\}} - \delta_{\{a,b\}} + \delta_{\{b,d\}} - \delta_{\{b,c,d\}} + \delta_{\{a,b,c,d\}}) \\
 &\quad - (\delta_{\{d\}} - \delta_{\{a,d\}} - \delta_{\{c,d\}} + \delta_{\{a,c,d\}})
 \end{aligned}$$

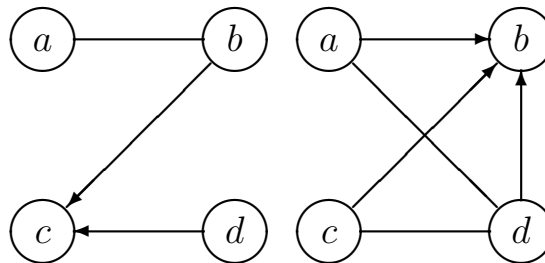

2.12.9.6 Differential imset (279)

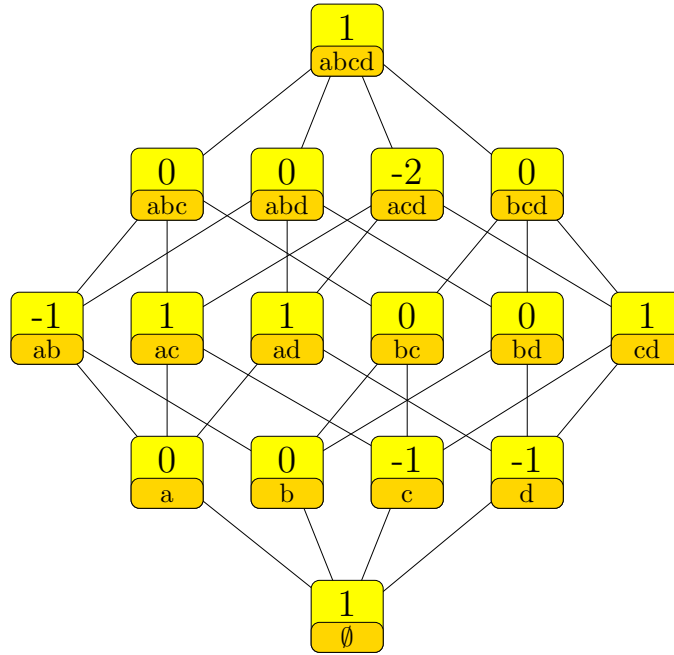

$$\begin{aligned}
 & \delta_\emptyset - \delta_{\{c\}} - \delta_{\{d\}} - \delta_{\{a,b\}} + \delta_{\{a,c\}} + \delta_{\{a,d\}} + \delta_{\{c,d\}} - 2\delta_{\{a,c,d\}} + \delta_{\{a,b,c,d\}} \\
 &= u_{\langle c,d|\emptyset \rangle} + u_{\langle b,d|ac \rangle} + u_{\langle b,c|a \rangle} - u_{\langle c,d|a \rangle} \\
 &= (\delta_\emptyset - \delta_{\{d\}} - \delta_{\{a,b\}} + \delta_{\{a,d\}} - \delta_{\{a,c,d\}} + \delta_{\{a,b,c,d\}}) \\
 &\quad - (\delta_{\{c\}} - \delta_{\{a,c\}} - \delta_{\{c,d\}} + \delta_{\{a,c,d\}}) \\
 &= (\delta_\emptyset - \delta_{\{c\}} - \delta_{\{a,b\}} + \delta_{\{a,c\}} - \delta_{\{a,c,d\}} + \delta_{\{a,b,c,d\}}) \\
 &\quad - (\delta_{\{d\}} - \delta_{\{a,d\}} - \delta_{\{c,d\}} + \delta_{\{a,c,d\}}) \\
 &= (\delta_\emptyset + \delta_{\{a\}} - \delta_{\{c\}} - \delta_{\{d\}} - \delta_{\{a,b\}} + \delta_{\{c,d\}} - \delta_{\{a,c,d\}} + \delta_{\{a,b,c,d\}}) \\
 &\quad - (\delta_{\{a\}} - \delta_{\{a,c\}} - \delta_{\{a,d\}} + \delta_{\{a,c,d\}})
 \end{aligned}$$

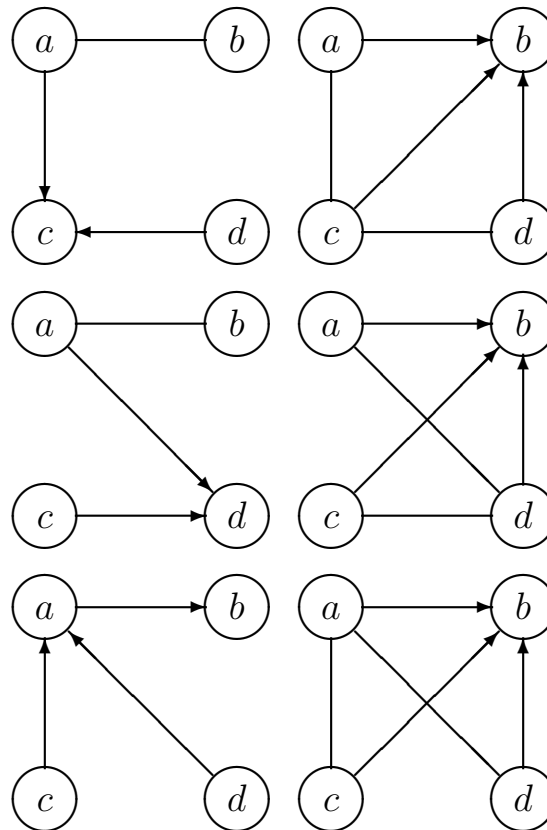

2.12.9.7 Differential imset (280)

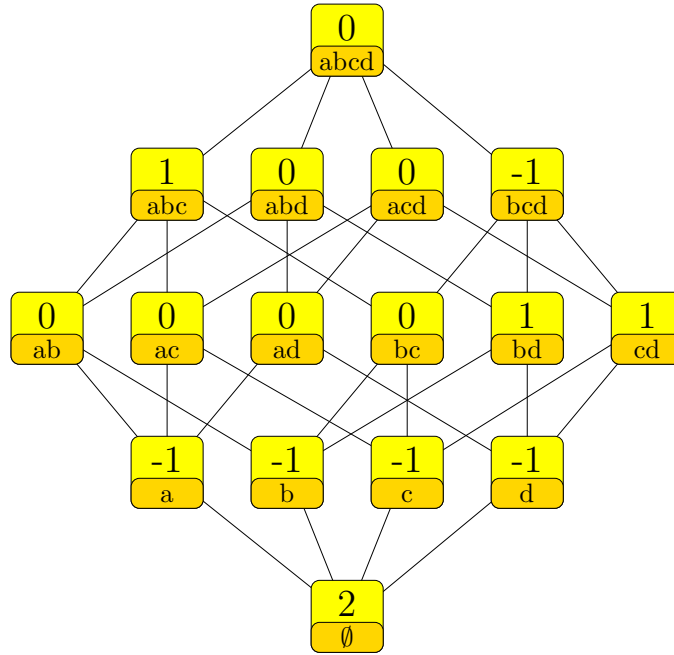

$$\begin{aligned}
 &+2\delta_\emptyset - \delta_{\{a\}} - \delta_{\{b\}} - \delta_{\{c\}} - \delta_{\{d\}} + \delta_{\{b,d\}} + \delta_{\{c,d\}} + \delta_{\{a,b,c\}} - \delta_{\{b,c,d\}} \\
 &= u_{\langle a,b|\emptyset \rangle} + u_{\langle a,c|\emptyset \rangle} + u_{\langle b,c|a \rangle} - u_{\langle b,c|d \rangle} \\
 &= (+2\delta_\emptyset - \delta_{\{a\}} - \delta_{\{b\}} - \delta_{\{c\}} + \delta_{\{b,c\}} - \delta_{\{b,c,d\}} + \delta_{\{a,b,c,d\}}) \\
 &\quad - (\delta_{\{d\}} + \delta_{\{b,c\}} - \delta_{\{b,d\}} - \delta_{\{c,d\}} - \delta_{\{a,b,c\}} + \delta_{\{a,b,c,d\}})
 \end{aligned}$$

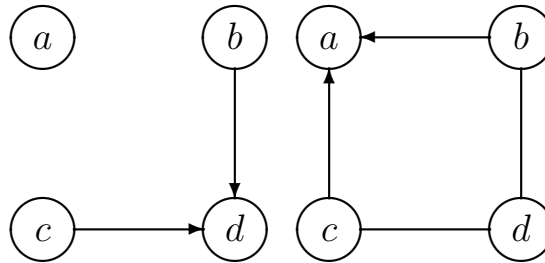

2.12.12 Number of nonzero values 12

2.12.12.1 Differential imset (281)

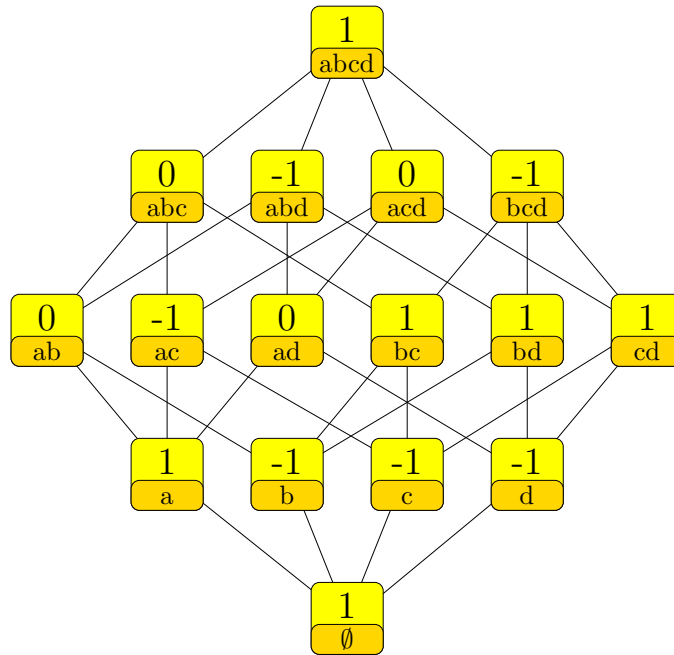

$$\begin{aligned}
 & \delta_\emptyset + \delta_{\{a\}} - \delta_{\{b\}} - \delta_{\{c\}} - \delta_{\{d\}} - \delta_{\{a,c\}} + \delta_{\{b,c\}} + \delta_{\{b,d\}} + \delta_{\{c,d\}} - \delta_{\{a,b,d\}} - \delta_{\{b,c,d\}} + \delta_{\{a,b,c,d\}} \\
 &= u_{\langle b,d|\emptyset \rangle} + u_{\langle c,d|ab \rangle} + u_{\langle b,c|a \rangle} - u_{\langle b,d|c \rangle} \\
 &= (\delta_\emptyset + \delta_{\{a\}} - \delta_{\{b\}} - \delta_{\{d\}} - \delta_{\{a,c\}} + \delta_{\{b,d\}} - \delta_{\{a,b,d\}} + \delta_{\{a,b,c,d\}}) \\
 &\quad - (\delta_{\{c\}} - \delta_{\{b,c\}} - \delta_{\{c,d\}} + \delta_{\{b,c,d\}})
 \end{aligned}$$

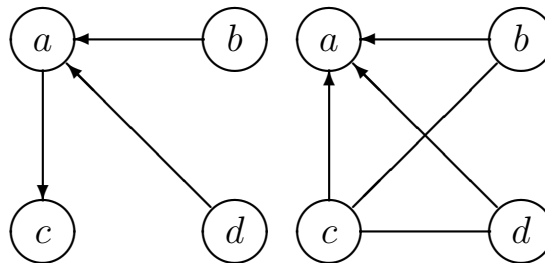

## 2.14 Squared Euclidean length 14

### 2.14.8 Number of nonzero values 8

#### 2.14.8.1 Differential imset (282)

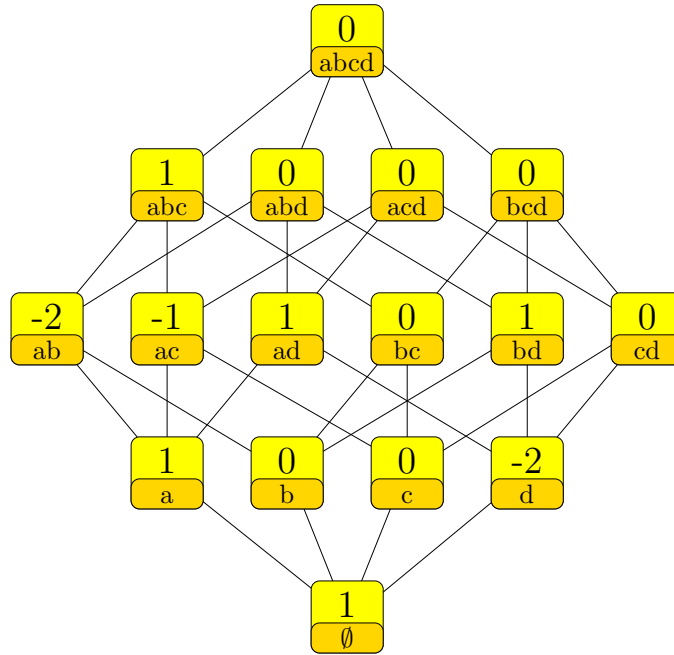

$$\begin{aligned}
 & \delta_{\emptyset} + \delta_{\{a\}} - 2\delta_{\{d\}} - 2\delta_{\{a,b\}} - \delta_{\{a,c\}} + \delta_{\{a,d\}} + \delta_{\{b,d\}} + \delta_{\{a,b,c\}} \\
 &= u_{\langle a,d|\emptyset \rangle} + u_{\langle b,c|a \rangle} + u_{\langle b,d|a \rangle} - u_{\langle a,b|d \rangle} \\
 &= (\delta_{\emptyset} + \delta_{\{a\}} - \delta_{\{d\}} - \delta_{\{a,b\}} - \delta_{\{a,c\}} + \delta_{\{a,b,c,d\}}) \\
 &\quad - (\delta_{\{d\}} + \delta_{\{a,b\}} - \delta_{\{a,d\}} - \delta_{\{b,d\}} - \delta_{\{a,b,c\}} + \delta_{\{a,b,c,d\}})
 \end{aligned}$$

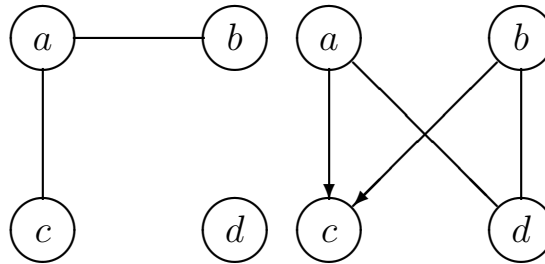

2.14.8.2 Differential imset (283)

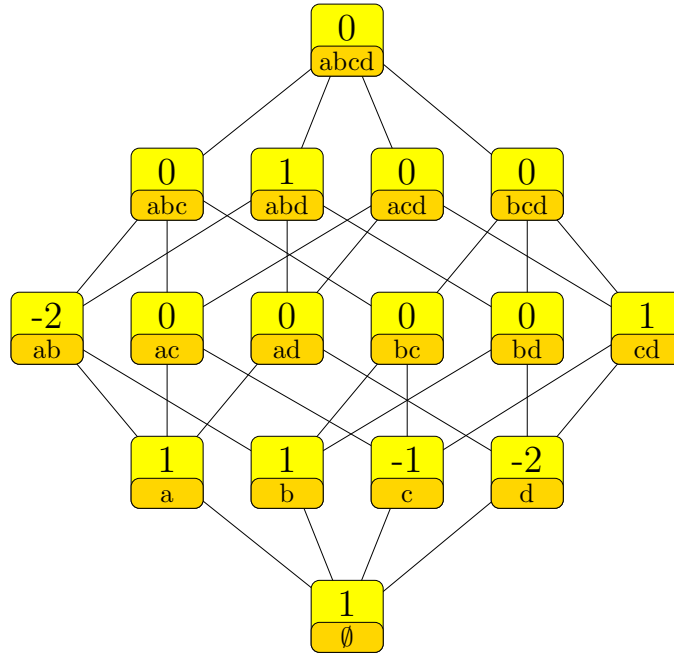

$$\begin{aligned}
 & \delta_{\emptyset} + \delta_{\{a\}} + \delta_{\{b\}} - \delta_{\{c\}} - 2\delta_{\{d\}} - 2\delta_{\{a,b\}} + \delta_{\{c,d\}} + \delta_{\{a,b,d\}} \\
 &= -u_{\langle a,b|\emptyset \rangle} + u_{\langle a,d|\emptyset \rangle} + u_{\langle c,d|\emptyset \rangle} + u_{\langle b,d|a \rangle} \\
 &= (+2\delta_{\emptyset} - \delta_{\{c\}} - \delta_{\{d\}} - \delta_{\{a,b\}} + \delta_{\{a,b,c,d\}}) \\
 &\quad - (\delta_{\emptyset} - \delta_{\{a\}} - \delta_{\{b\}} + \delta_{\{d\}} + \delta_{\{a,b\}} - \delta_{\{c,d\}} - \delta_{\{a,b,d\}} + \delta_{\{a,b,c,d\}})
 \end{aligned}$$

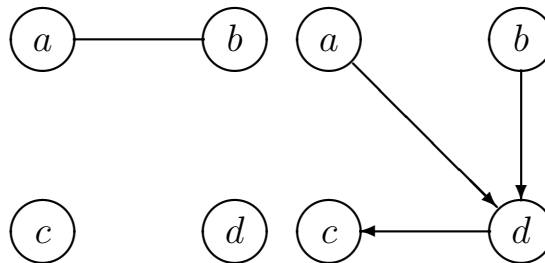

2.14.8.3 Differential imset (284)

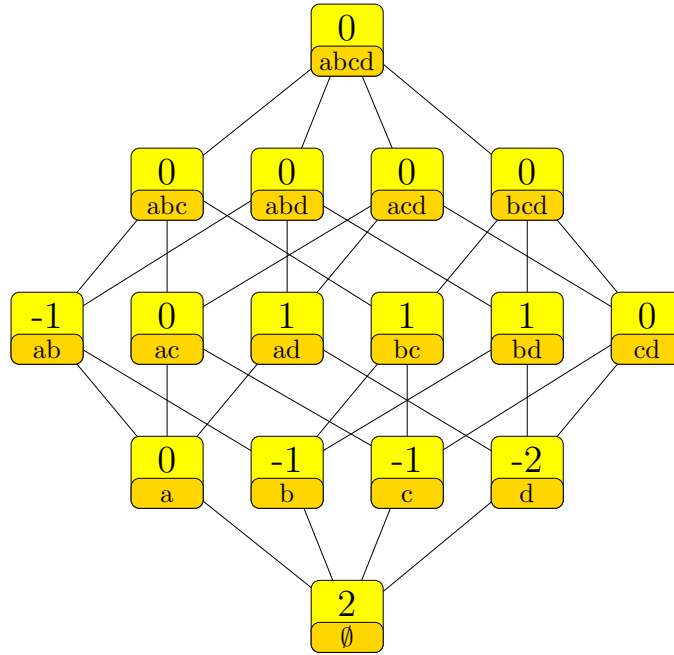

$$\begin{aligned}
 &+2\delta_\emptyset - \delta_{\{b\}} - \delta_{\{c\}} - 2\delta_{\{d\}} - \delta_{\{a,b\}} + \delta_{\{a,d\}} + \delta_{\{b,c\}} + \delta_{\{b,d\}} \\
 &= -u_{\langle a,b|\emptyset \rangle} + u_{\langle a,d|\emptyset \rangle} + u_{\langle b,c|\emptyset \rangle} + u_{\langle b,d|\emptyset \rangle} \\
 &= (+2\delta_\emptyset - \delta_{\{c\}} - \delta_{\{d\}} - \delta_{\{a,b\}} + \delta_{\{a,b,c,d\}}) \\
 &\quad - (\delta_{\{b\}} + \delta_{\{d\}} - \delta_{\{a,d\}} - \delta_{\{b,c\}} - \delta_{\{b,d\}} + \delta_{\{a,b,c,d\}})
 \end{aligned}$$

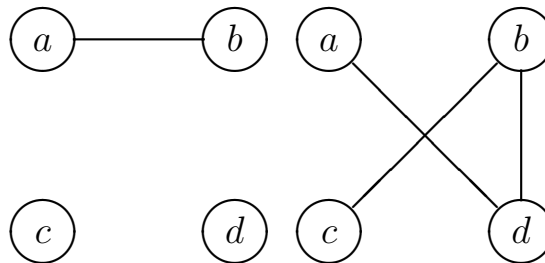

2.14.8.4 Differential imset (285)

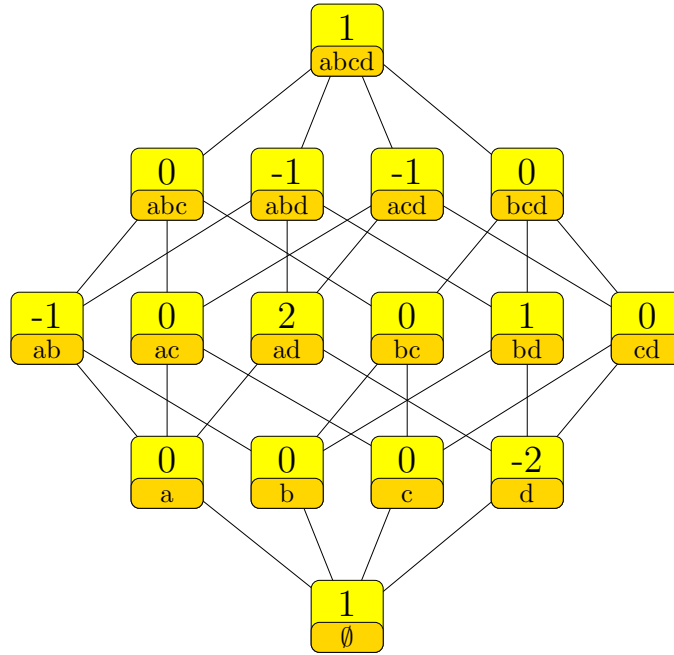

$$\begin{aligned}
 & \delta_\emptyset - 2\delta_{\{d\}} - \delta_{\{a,b\}} + 2\delta_{\{a,d\}} + \delta_{\{b,d\}} - \delta_{\{a,b,d\}} - \delta_{\{a,c,d\}} + \delta_{\{a,b,c,d\}} \\
 &= u_{\langle a,d|\emptyset \rangle} + u_{\langle b,d|ac \rangle} + u_{\langle b,c|a \rangle} - u_{\langle a,b|d \rangle} \\
 &= (\delta_\emptyset - \delta_{\{d\}} - \delta_{\{a,b\}} + \delta_{\{a,d\}} - \delta_{\{a,c,d\}} + \delta_{\{a,b,c,d\}}) \\
 &\quad - (\delta_{\{d\}} - \delta_{\{a,d\}} - \delta_{\{b,d\}} + \delta_{\{a,b,d\}})
 \end{aligned}$$

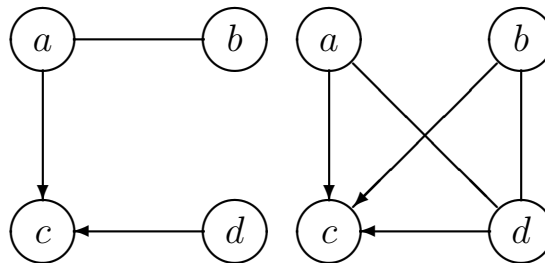



2.14.8.5 Differential imset (286)

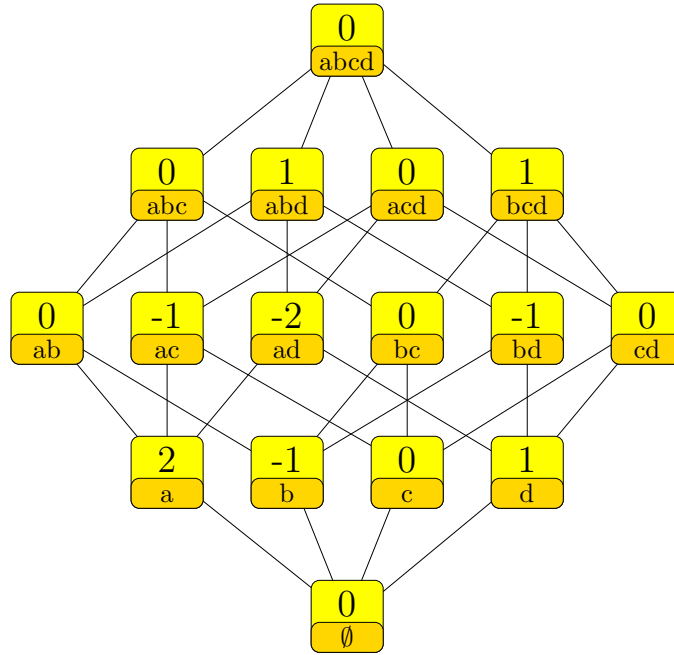

$$\begin{aligned}
 &+2\delta_{\{a\}} - \delta_{\{b\}} + \delta_{\{d\}} - \delta_{\{a,c\}} - 2\delta_{\{a,d\}} - \delta_{\{b,d\}} + \delta_{\{a,b,d\}} + \delta_{\{b,c,d\}} \\
 &= u_{\langle a,b|\emptyset \rangle} - u_{\langle a,d|\emptyset \rangle} + u_{\langle c,d|ab \rangle} - u_{\langle a,c|bd \rangle} + u_{\langle b,c|a \rangle} + u_{\langle b,d|a \rangle} \\
 &= (\delta_{\emptyset} + \delta_{\{a\}} - \delta_{\{b\}} - \delta_{\{a,c\}} - \delta_{\{a,d\}} + \delta_{\{a,b,c,d\}}) \\
 &\quad - (\delta_{\emptyset} - \delta_{\{a\}} - \delta_{\{d\}} + \delta_{\{a,d\}} + \delta_{\{b,d\}} - \delta_{\{a,b,d\}} - \delta_{\{b,c,d\}} + \delta_{\{a,b,c,d\}})
 \end{aligned}$$

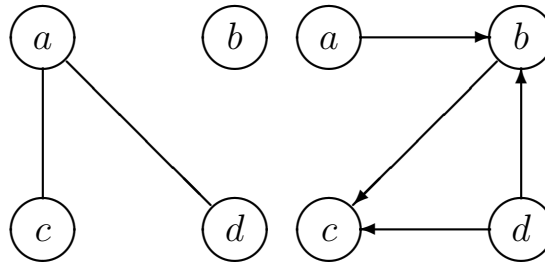

2.14.8.6 Differential imset (287)

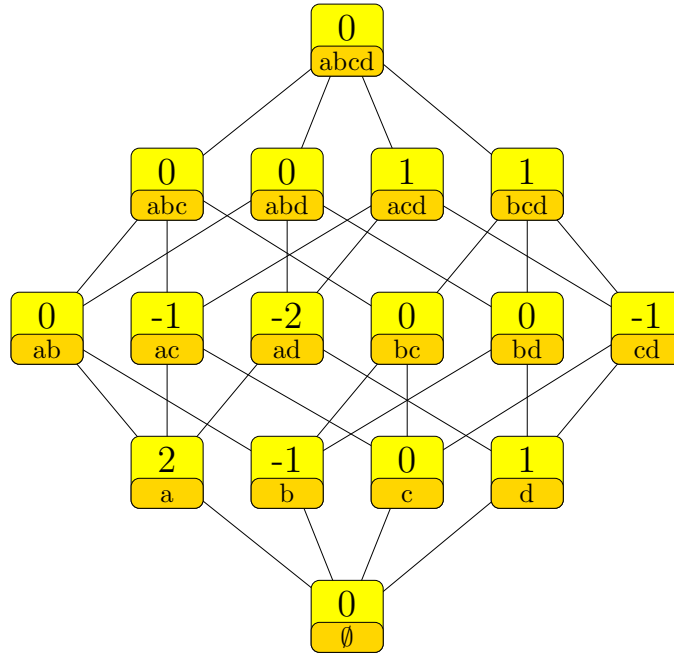

$$\begin{aligned}
 &+2\delta_{\{a\}} - \delta_{\{b\}} + \delta_{\{d\}} - \delta_{\{a,c\}} - 2\delta_{\{a,d\}} - \delta_{\{c,d\}} + \delta_{\{a,c,d\}} + \delta_{\{b,c,d\}} \\
 &= -u_{\langle a,d|\emptyset\rangle} + u_{\langle b,c|\emptyset\rangle} + u_{\langle c,d|a\rangle} + u_{\langle b,d|c\rangle} \\
 &= (\delta_{\emptyset} + \delta_{\{a\}} - \delta_{\{b\}} - \delta_{\{a,c\}} - \delta_{\{a,d\}} + \delta_{\{a,b,c,d\}}) \\
 &\quad - (\delta_{\emptyset} - \delta_{\{a\}} - \delta_{\{d\}} + \delta_{\{a,d\}} + \delta_{\{c,d\}} - \delta_{\{a,c,d\}} - \delta_{\{b,c,d\}} + \delta_{\{a,b,c,d\}})
 \end{aligned}$$

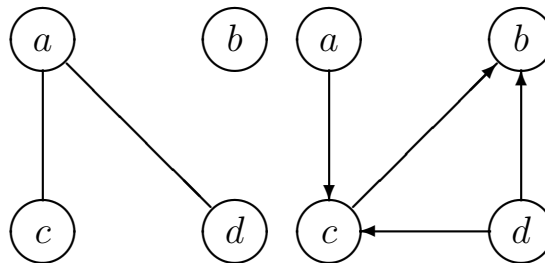

2.14.8.7 Differential imset (288)

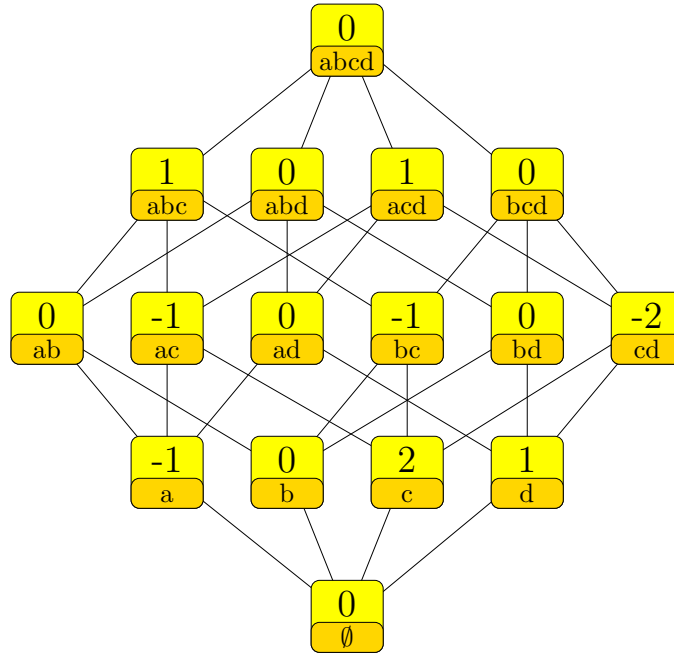

$$\begin{aligned}
 & -\delta_{\{a\}} + 2\delta_{\{c\}} + \delta_{\{d\}} - \delta_{\{a,c\}} - \delta_{\{b,c\}} - 2\delta_{\{c,d\}} + \delta_{\{a,b,c\}} + \delta_{\{a,c,d\}} \\
 &= u_{\langle a,b|\emptyset \rangle} - u_{\langle c,d|\emptyset \rangle} + u_{\langle a,c|b \rangle} + u_{\langle a,d|c \rangle} \\
 &= (\delta_{\emptyset} - \delta_{\{a\}} + \delta_{\{c\}} - \delta_{\{b,c\}} - \delta_{\{c,d\}} + \delta_{\{a,b,c,d\}}) \\
 &\quad - (\delta_{\emptyset} - \delta_{\{c\}} - \delta_{\{d\}} + \delta_{\{a,c\}} + \delta_{\{c,d\}} - \delta_{\{a,b,c\}} - \delta_{\{a,c,d\}} + \delta_{\{a,b,c,d\}})
 \end{aligned}$$

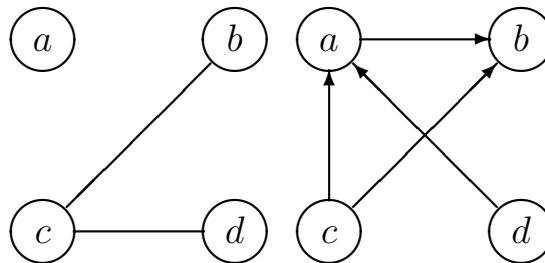

2.14.8.8 Differential imset (289)

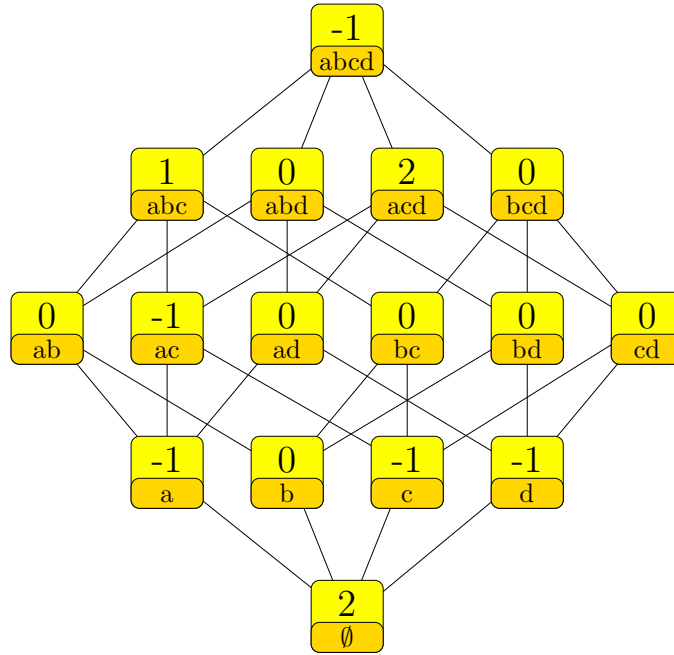

$$\begin{aligned}
 &+2\delta_\emptyset - \delta_{\{a\}} - \delta_{\{c\}} - \delta_{\{d\}} - \delta_{\{a,c\}} + \delta_{\{a,b,c\}} + 2\delta_{\{a,c,d\}} - \delta_{\{a,b,c,d\}} \\
 &= u_{\langle a,c|\emptyset \rangle} + u_{\langle a,d|\emptyset \rangle} - u_{\langle b,d|ac \rangle} + u_{\langle c,d|a \rangle} \\
 &= (+2\delta_\emptyset - \delta_{\{a\}} - \delta_{\{c\}} - \delta_{\{d\}} + \delta_{\{a,c,d\}}) \\
 &\quad - (\delta_{\{a,c\}} - \delta_{\{a,b,c\}} - \delta_{\{a,c,d\}} + \delta_{\{a,b,c,d\}})
 \end{aligned}$$

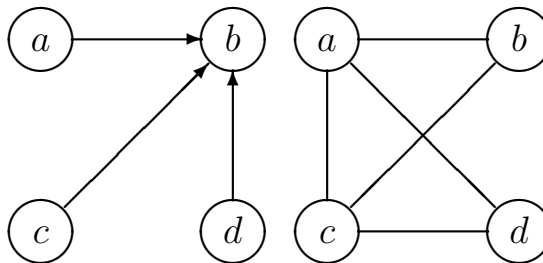

2.14.8.9 Differential imset (290)

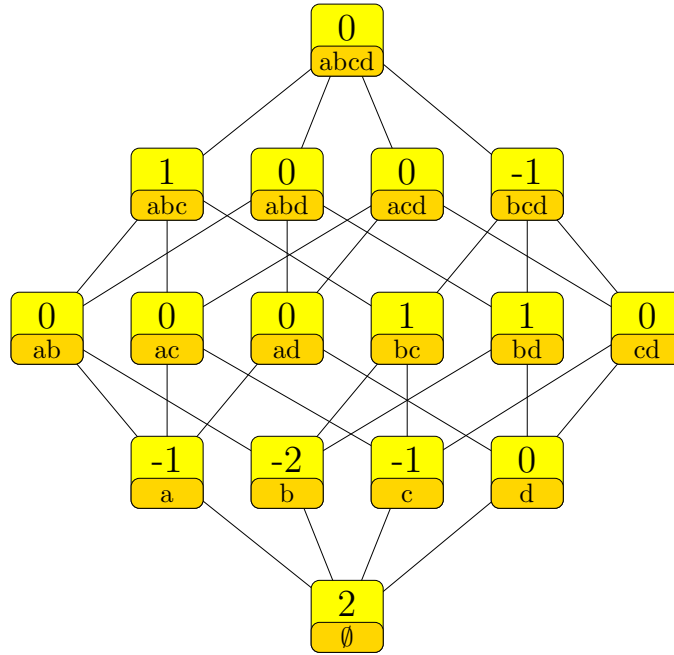

$$\begin{aligned}
 &+2\delta_\emptyset - \delta_{\{a\}} - 2\delta_{\{b\}} - \delta_{\{c\}} + \delta_{\{b,c\}} + \delta_{\{b,d\}} + \delta_{\{a,b,c\}} - \delta_{\{b,c,d\}} \\
 &= u_{\langle a,b|\emptyset \rangle} + u_{\langle a,c|\emptyset \rangle} + u_{\langle b,c|a \rangle} - u_{\langle c,d|b \rangle} \\
 &= (+2\delta_\emptyset - \delta_{\{a\}} - \delta_{\{b\}} - \delta_{\{c\}} + \delta_{\{a,b,c\}}) \\
 &\quad - (\delta_{\{b\}} - \delta_{\{b,c\}} - \delta_{\{b,d\}} + \delta_{\{b,c,d\}})
 \end{aligned}$$

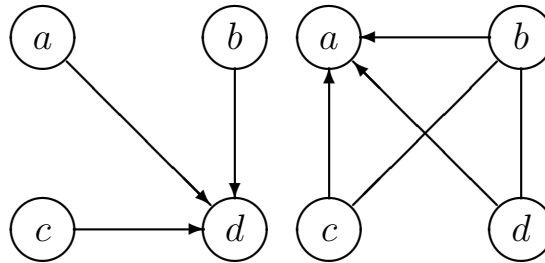

2.14.8.10 Differential imset (291)

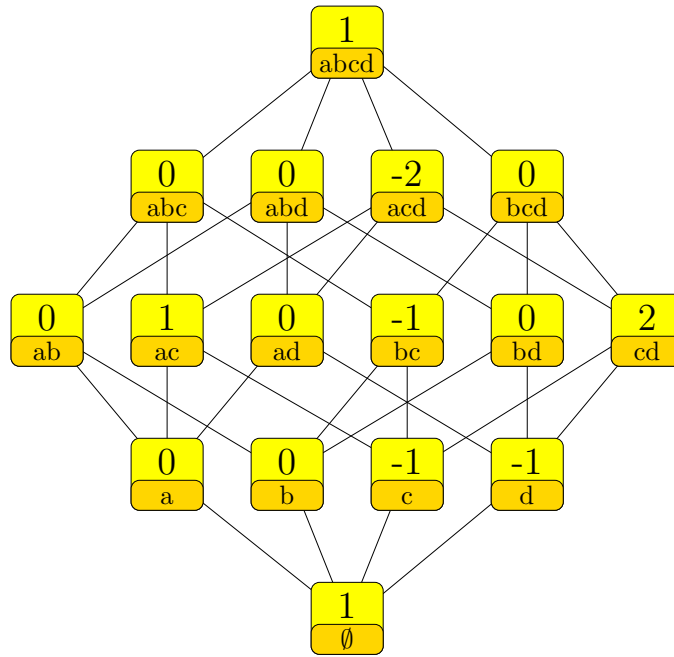

$$\begin{aligned}
 & \delta_{\emptyset} - \delta_{\{c\}} - \delta_{\{d\}} + \delta_{\{a,c\}} - \delta_{\{b,c\}} + 2\delta_{\{c,d\}} - 2\delta_{\{a,c,d\}} + \delta_{\{a,b,c,d\}} \\
 &= u_{\langle b,d|\emptyset \rangle} + u_{\langle a,b|cd \rangle} - u_{\langle a,d|c \rangle} + u_{\langle c,d|b \rangle} \\
 &= (\delta_{\emptyset} - \delta_{\{d\}} - \delta_{\{b,c\}} + \delta_{\{c,d\}} - \delta_{\{a,c,d\}} + \delta_{\{a,b,c,d\}}) \\
 &\quad - (\delta_{\{c\}} - \delta_{\{a,c\}} - \delta_{\{c,d\}} + \delta_{\{a,c,d\}})
 \end{aligned}$$

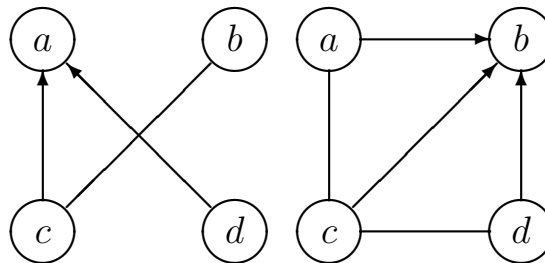

2.14.8.11 Differential imset (292)

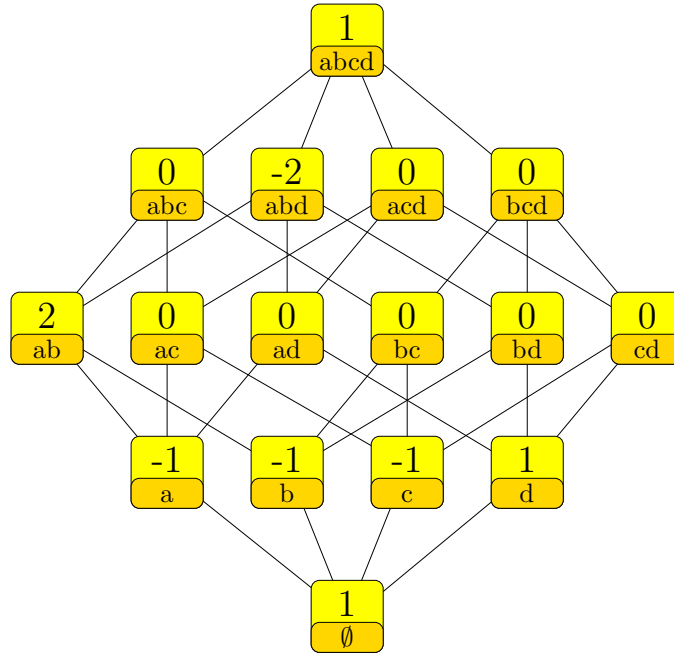

$$\begin{aligned}
 & \delta_\emptyset - \delta_{\{a\}} - \delta_{\{b\}} - \delta_{\{c\}} + \delta_{\{d\}} + 2\delta_{\{a,b\}} - 2\delta_{\{a,b,d\}} + \delta_{\{a,b,c,d\}} \\
 &= u_{\langle a,b|\emptyset \rangle} + u_{\langle a,c|\emptyset \rangle} - u_{\langle a,d|\emptyset \rangle} + u_{\langle c,d|ab \rangle} + u_{\langle b,c|a \rangle} - u_{\langle b,d|a \rangle} \\
 &= (+2\delta_\emptyset - \delta_{\{a\}} - \delta_{\{b\}} - \delta_{\{c\}} + \delta_{\{a,b\}} - \delta_{\{a,b,d\}} + \delta_{\{a,b,c,d\}}) \\
 &\quad - (\delta_\emptyset - \delta_{\{d\}} - \delta_{\{a,b\}} + \delta_{\{a,b,d\}})
 \end{aligned}$$

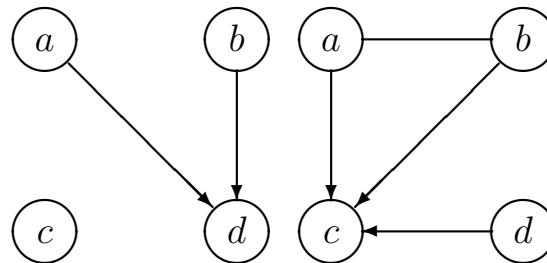

2.14.11 Number of nonzero values 11

2.14.11.1 Differential imset (293)

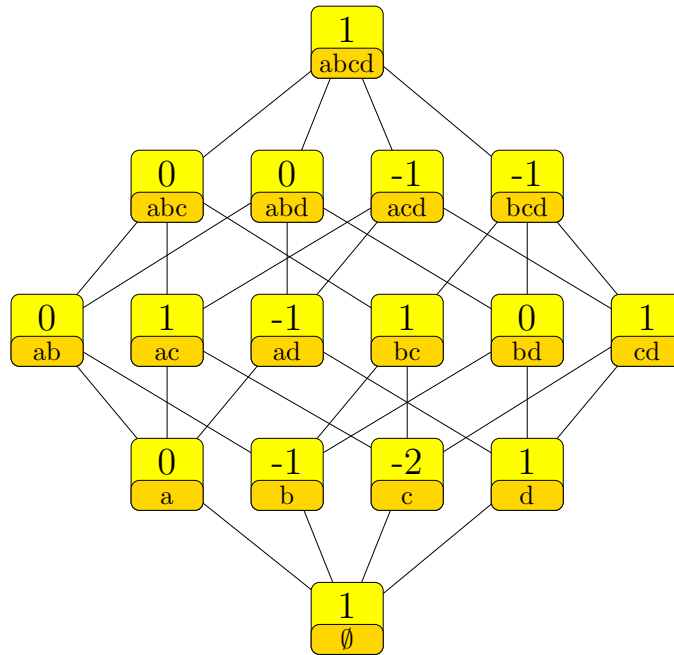

$$\begin{aligned}
 & \delta_{\emptyset} - \delta_{\{b\}} - 2\delta_{\{c\}} + \delta_{\{d\}} + \delta_{\{a,c\}} - \delta_{\{a,d\}} + \delta_{\{b,c\}} + \delta_{\{c,d\}} - \delta_{\{a,c,d\}} - \delta_{\{b,c,d\}} + \delta_{\{a,b,c,d\}} \\
 &= u_{\langle b,c|\emptyset \rangle} + u_{\langle a,c|bd \rangle} - u_{\langle a,d|c \rangle} + u_{\langle a,b|d \rangle} \\
 &= (\delta_{\emptyset} - \delta_{\{b\}} - \delta_{\{c\}} + \delta_{\{d\}} - \delta_{\{a,d\}} + \delta_{\{b,c\}} - \delta_{\{b,c,d\}} + \delta_{\{a,b,c,d\}}) \\
 &\quad - (\delta_{\{c\}} - \delta_{\{a,c\}} - \delta_{\{c,d\}} + \delta_{\{a,c,d\}})
 \end{aligned}$$

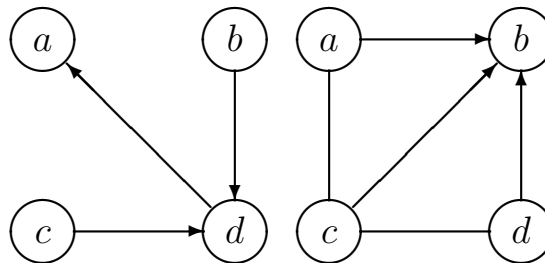



2.14.11.2 Differential imset (294)

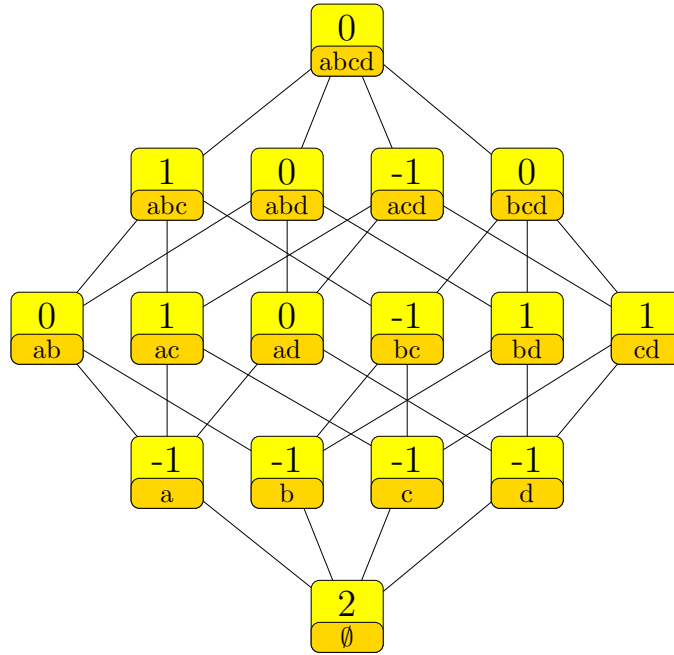

$$\begin{aligned}
 &+2\delta_\emptyset - \delta_{\{a\}} - \delta_{\{b\}} - \delta_{\{c\}} - \delta_{\{d\}} + \delta_{\{a,c\}} - \delta_{\{b,c\}} + \delta_{\{b,d\}} + \delta_{\{c,d\}} + \delta_{\{a,b,c\}} - \delta_{\{a,c,d\}} \\
 &= u_{\langle a,c|\emptyset\rangle} + u_{\langle b,d|\emptyset\rangle} - u_{\langle a,d|bc\rangle} + u_{\langle a,b|cd\rangle} \\
 &= (+2\delta_\emptyset - \delta_{\{a\}} - \delta_{\{b\}} - \delta_{\{c\}} + \delta_{\{a,c\}} - \delta_{\{a,c,d\}} + \delta_{\{a,b,c,d\}}) \\
 &\quad - (\delta_{\{d\}} + \delta_{\{b,c\}} - \delta_{\{b,d\}} - \delta_{\{c,d\}} - \delta_{\{a,b,c\}} + \delta_{\{a,b,c,d\}})
 \end{aligned}$$

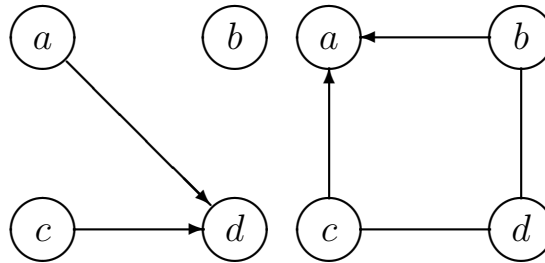

## 2.16 Squared Euclidean length 16

### 2.16.7 Number of nonzero values 7

#### 2.16.7.1 Differential imset (295)

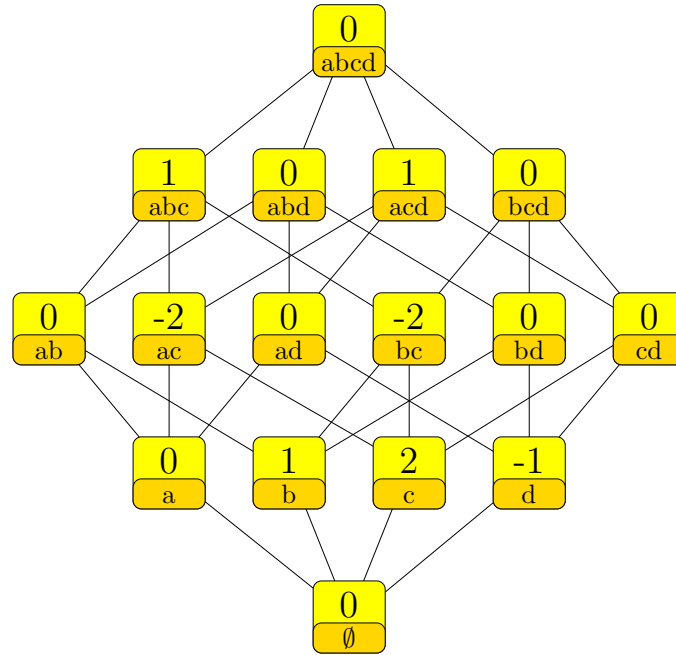

$$\begin{aligned}
 & \delta_{\{b\}} + 2\delta_{\{c\}} - \delta_{\{d\}} - 2\delta_{\{a,c\}} - 2\delta_{\{b,c\}} + \delta_{\{a,b,c\}} + \delta_{\{a,c,d\}} \\
 &= u_{\langle a,d|\emptyset\rangle} - u_{\langle b,c|\emptyset\rangle} + u_{\langle c,d|a\rangle} + u_{\langle a,b|c\rangle} \\
 &= (\delta_{\emptyset} + \delta_{\{c\}} - \delta_{\{d\}} - \delta_{\{a,c\}} - \delta_{\{b,c\}} + \delta_{\{a,b,c,d\}}) \\
 &\quad - (\delta_{\emptyset} - \delta_{\{b\}} - \delta_{\{c\}} + \delta_{\{a,c\}} + \delta_{\{b,c\}} - \delta_{\{a,b,c\}} - \delta_{\{a,c,d\}} + \delta_{\{a,b,c,d\}})
 \end{aligned}$$

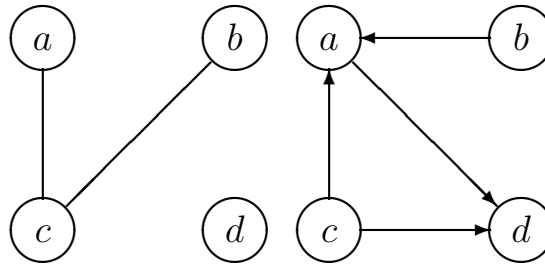

2.16.7.2 Differential imset (296)

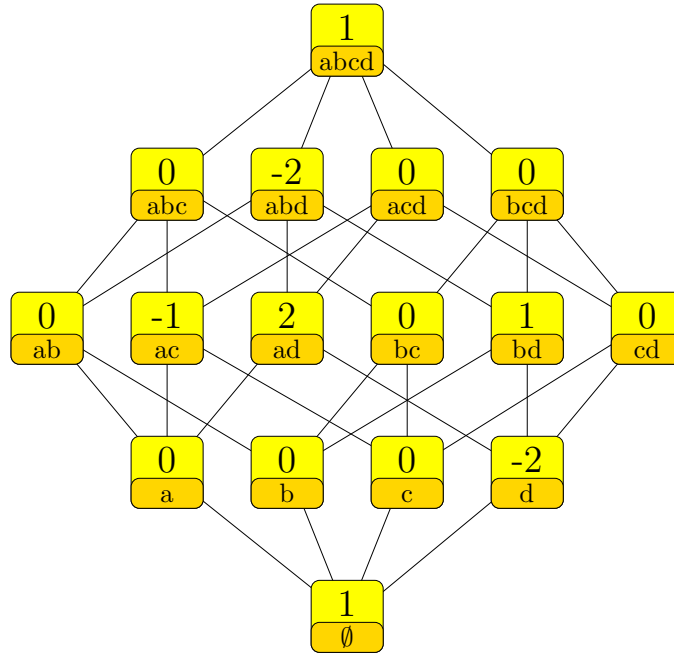

$$\begin{aligned}
 & \delta_\emptyset - 2\delta_{\{d\}} - \delta_{\{a,c\}} + 2\delta_{\{a,d\}} + \delta_{\{b,d\}} - 2\delta_{\{a,b,d\}} + \delta_{\{a,b,c,d\}} \\
 &= u_{\langle a,d|\emptyset \rangle} + u_{\langle c,d|ab \rangle} + u_{\langle b,c|a \rangle} - u_{\langle a,b|d \rangle} \\
 &= (\delta_\emptyset - \delta_{\{d\}} - \delta_{\{a,c\}} + \delta_{\{a,d\}} - \delta_{\{a,b,d\}} + \delta_{\{a,b,c,d\}}) \\
 &\quad - (\delta_{\{d\}} - \delta_{\{a,d\}} - \delta_{\{b,d\}} + \delta_{\{a,b,d\}})
 \end{aligned}$$

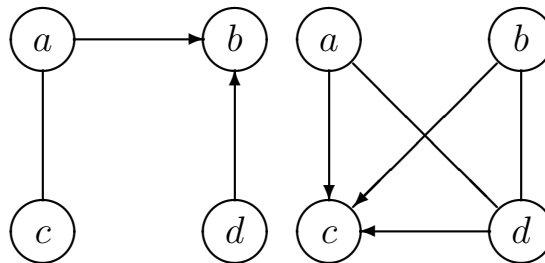

2.16.7.3 Differential imset (297)

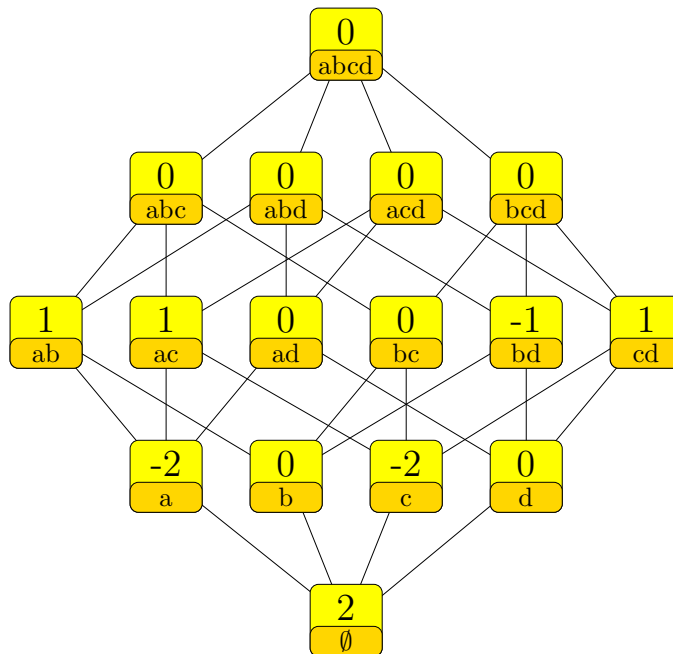

$$\begin{aligned}
 &+2\delta_\emptyset - 2\delta_{\{a\}} - 2\delta_{\{c\}} + \delta_{\{a,b\}} + \delta_{\{a,c\}} - \delta_{\{b,d\}} + \delta_{\{c,d\}} \\
 &= u_{\langle a,b|\emptyset \rangle} + u_{\langle a,c|\emptyset \rangle} - u_{\langle b,d|\emptyset \rangle} + u_{\langle c,d|\emptyset \rangle} \\
 &= (+2\delta_\emptyset - \delta_{\{a\}} - \delta_{\{c\}} - \delta_{\{b,d\}} + \delta_{\{a,b,c,d\}}) \\
 &\quad - (\delta_{\{a\}} + \delta_{\{c\}} - \delta_{\{a,b\}} - \delta_{\{a,c\}} - \delta_{\{c,d\}} + \delta_{\{a,b,c,d\}})
 \end{aligned}$$

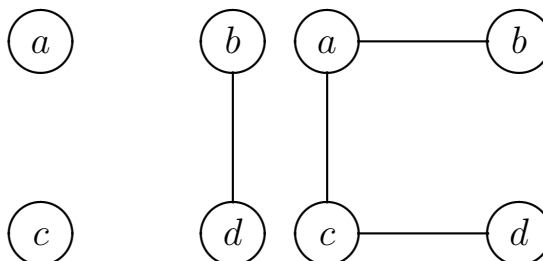

2.16.10 Number of nonzero values 10

2.16.10.1 Differential imset (298)

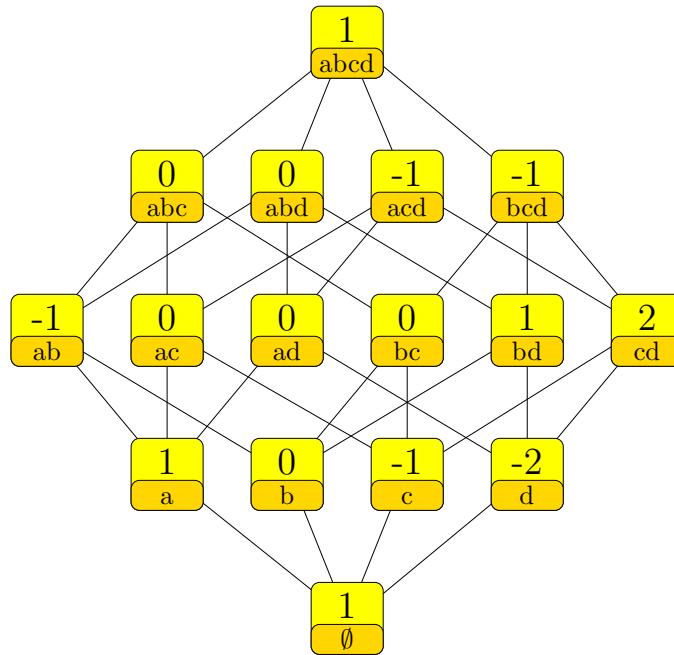

$$\begin{aligned}
 & \delta_\emptyset + \delta_{\{a\}} - \delta_{\{c\}} - 2\delta_{\{d\}} - \delta_{\{a,b\}} + \delta_{\{b,d\}} + 2\delta_{\{c,d\}} - \delta_{\{a,c,d\}} - \delta_{\{b,c,d\}} + \delta_{\{a,b,c,d\}} \\
 &= u_{\langle c,d|\emptyset \rangle} + u_{\langle b,d|ac \rangle} + u_{\langle b,c|a \rangle} - u_{\langle b,c|d \rangle} \\
 &= (\delta_\emptyset + \delta_{\{a\}} - \delta_{\{c\}} - \delta_{\{d\}} - \delta_{\{a,b\}} + \delta_{\{c,d\}} - \delta_{\{a,c,d\}} + \delta_{\{a,b,c,d\}}) \\
 &\quad - (\delta_{\{d\}} - \delta_{\{b,d\}} - \delta_{\{c,d\}} + \delta_{\{b,c,d\}})
 \end{aligned}$$

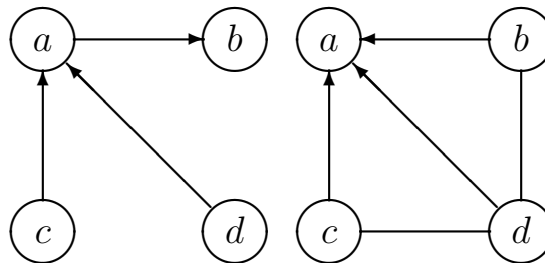

2.16.10.2 Differential imset (299)

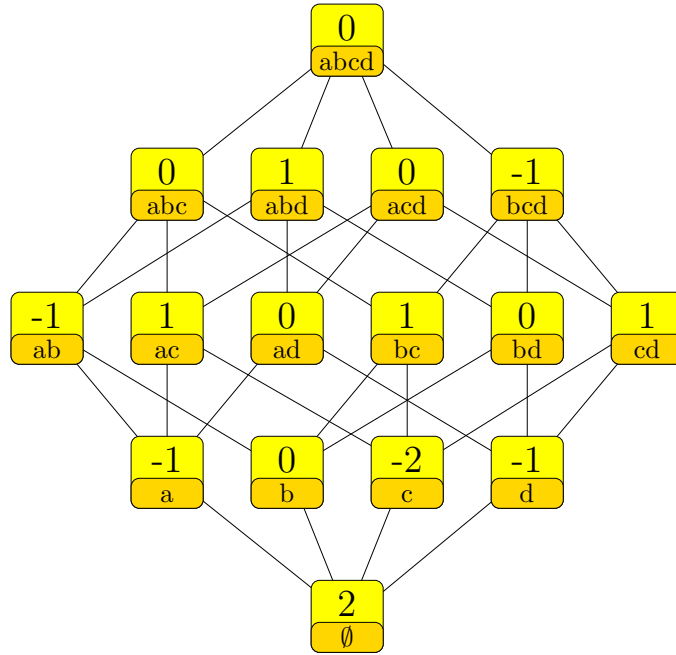

$$\begin{aligned}
 &+2\delta_\emptyset - \delta_{\{a\}} - 2\delta_{\{c\}} - \delta_{\{d\}} - \delta_{\{a,b\}} + \delta_{\{a,c\}} + \delta_{\{b,c\}} + \delta_{\{c,d\}} + \delta_{\{a,b,d\}} - \delta_{\{b,c,d\}} \\
 &= u_{\langle a,c|\emptyset \rangle} + u_{\langle a,d|\emptyset \rangle} + u_{\langle b,d|a \rangle} - u_{\langle b,d|c \rangle} \\
 &= (+2\delta_\emptyset - \delta_{\{a\}} - \delta_{\{c\}} - \delta_{\{d\}} + \delta_{\{c,d\}} - \delta_{\{b,c,d\}} + \delta_{\{a,b,c,d\}}) \\
 &\quad - (\delta_{\{c\}} + \delta_{\{a,b\}} - \delta_{\{a,c\}} - \delta_{\{b,c\}} - \delta_{\{a,b,d\}} + \delta_{\{a,b,c,d\}})
 \end{aligned}$$

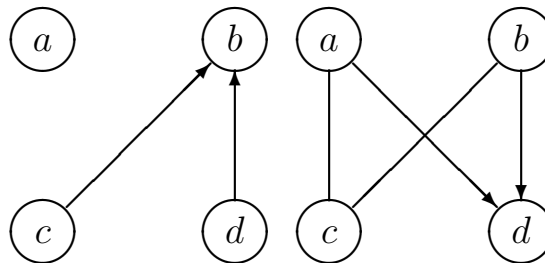

## 2.18 Squared Euclidean length 18

### 2.18.7 Number of nonzero values 7

#### 2.18.7.1 Differential imset (300)

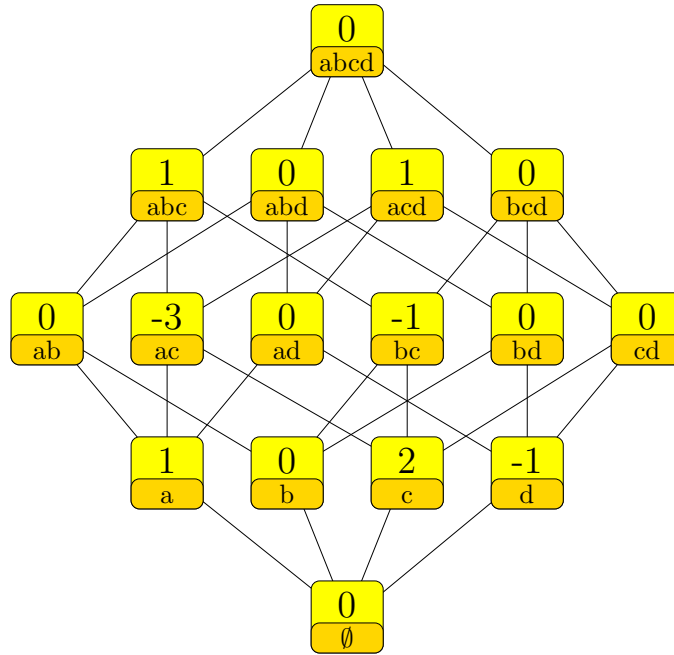

$$\begin{aligned}
 & \delta_{\{a\}} + 2\delta_{\{c\}} - \delta_{\{d\}} - 3\delta_{\{a,c\}} - \delta_{\{b,c\}} + \delta_{\{a,b,c\}} + \delta_{\{a,c,d\}} \\
 &= -u_{\langle a,c|\emptyset \rangle} + u_{\langle a,d|\emptyset \rangle} + u_{\langle c,d|a \rangle} + u_{\langle a,b|c \rangle} \\
 &= (\delta_{\emptyset} + \delta_{\{c\}} - \delta_{\{d\}} - \delta_{\{a,c\}} - \delta_{\{b,c\}} + \delta_{\{a,b,c,d\}}) \\
 &\quad - (\delta_{\emptyset} - \delta_{\{a\}} - \delta_{\{c\}} + 2\delta_{\{a,c\}} - \delta_{\{a,b,c\}} - \delta_{\{a,c,d\}} + \delta_{\{a,b,c,d\}})
 \end{aligned}$$

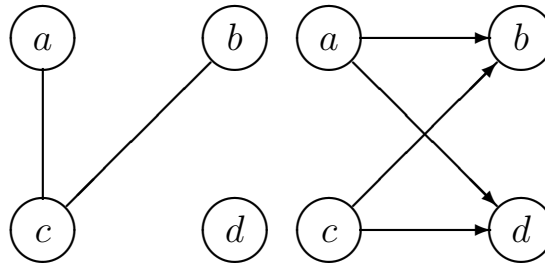

2.18.9 Number of nonzero values 9

2.18.9.1 Differential imset (301)

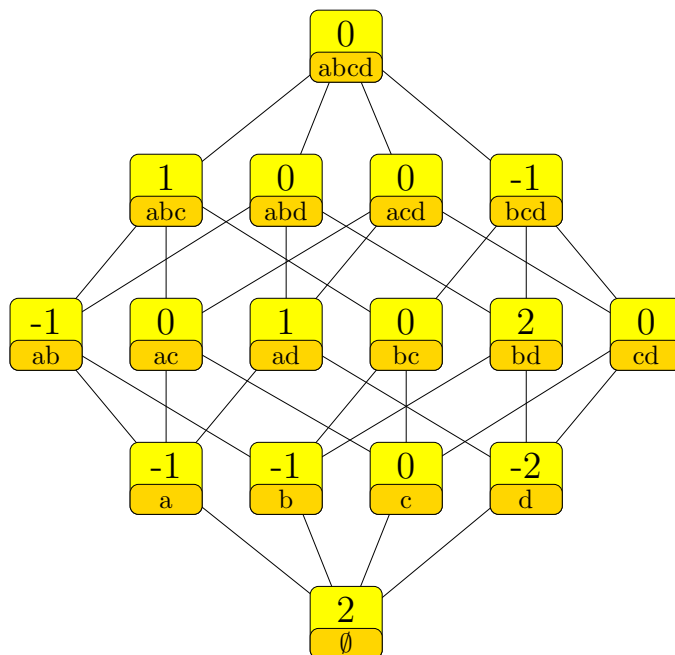

$$\begin{aligned}
 &+2\delta_\emptyset - \delta_{\{a\}} - \delta_{\{b\}} - 2\delta_{\{d\}} - \delta_{\{a,b\}} + \delta_{\{a,d\}} + 2\delta_{\{b,d\}} + \delta_{\{a,b,c\}} - \delta_{\{b,c,d\}} \\
 &= u_{\langle a,d|\emptyset \rangle} + u_{\langle b,d|\emptyset \rangle} - u_{\langle c,d|ab \rangle} + u_{\langle a,c|bd \rangle} \\
 &= (+2\delta_\emptyset - \delta_{\{a\}} - \delta_{\{b\}} - \delta_{\{d\}} + \delta_{\{b,d\}} - \delta_{\{b,c,d\}} + \delta_{\{a,b,c,d\}}) \\
 &\quad - (\delta_{\{d\}} + \delta_{\{a,b\}} - \delta_{\{a,d\}} - \delta_{\{b,d\}} - \delta_{\{a,b,c\}} + \delta_{\{a,b,c,d\}})
 \end{aligned}$$

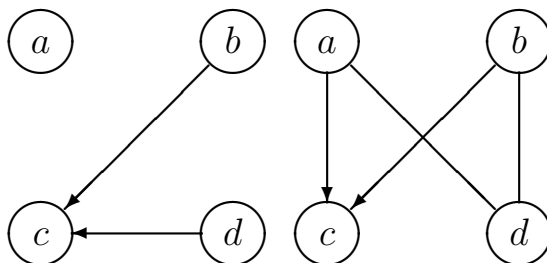



2.18.9.2 Differential imset (302)

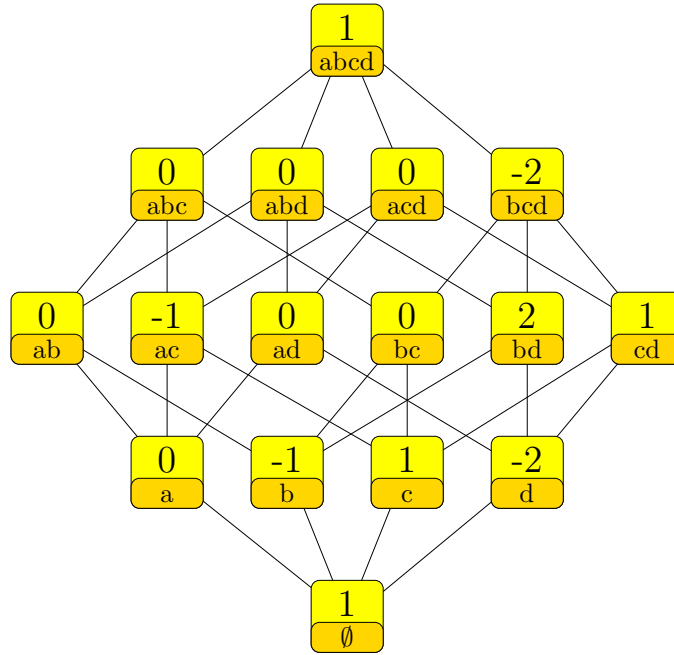

$$\begin{aligned}
 & \delta_\emptyset - \delta_{\{b\}} + \delta_{\{c\}} - 2\delta_{\{d\}} - \delta_{\{a,c\}} + 2\delta_{\{b,d\}} + \delta_{\{c,d\}} - 2\delta_{\{b,c,d\}} + \delta_{\{a,b,c,d\}} \\
 &= u_{\langle b,d|\emptyset \rangle} + u_{\langle a,d|bc \rangle} + u_{\langle a,b|c \rangle} - u_{\langle b,c|d \rangle} \\
 &= (\delta_\emptyset - \delta_{\{b\}} + \delta_{\{c\}} - \delta_{\{d\}} - \delta_{\{a,c\}} + \delta_{\{b,d\}} - \delta_{\{b,c,d\}} + \delta_{\{a,b,c,d\}}) \\
 &\quad - (\delta_{\{d\}} - \delta_{\{b,d\}} - \delta_{\{c,d\}} + \delta_{\{b,c,d\}})
 \end{aligned}$$

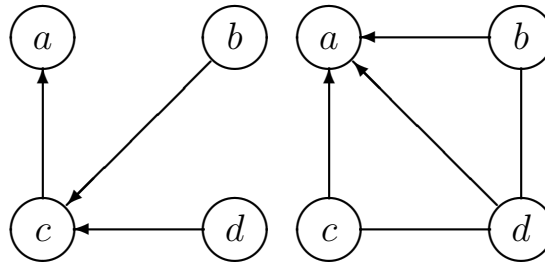

2.18.9.3 Differential imset (303)

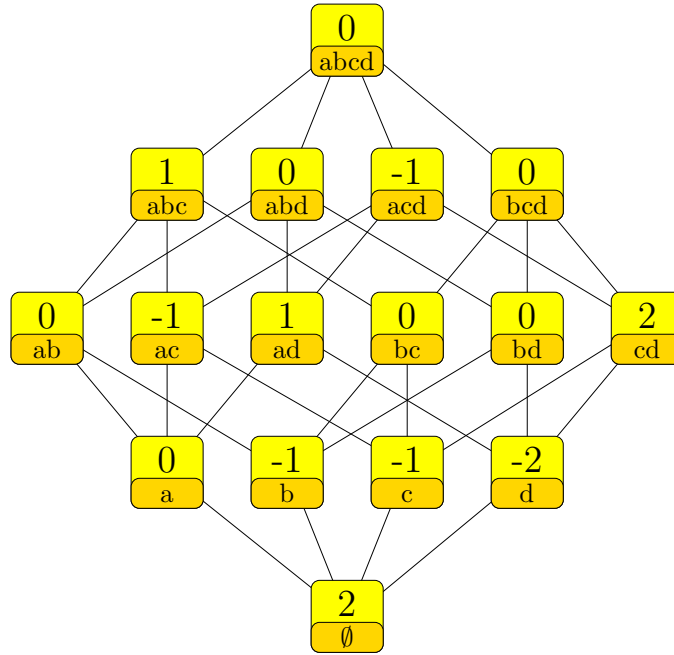

$$\begin{aligned}
 &+2\delta_\emptyset - \delta_{\{b\}} - \delta_{\{c\}} - 2\delta_{\{d\}} - \delta_{\{a,c\}} + \delta_{\{a,d\}} + 2\delta_{\{c,d\}} + \delta_{\{a,b,c\}} - \delta_{\{a,c,d\}} \\
 &= u_{\langle a,b|\emptyset \rangle} + u_{\langle c,d|\emptyset \rangle} + u_{\langle b,c|a \rangle} - u_{\langle a,c|d \rangle} \\
 &= (+2\delta_\emptyset - \delta_{\{b\}} - \delta_{\{c\}} - \delta_{\{d\}} + \delta_{\{c,d\}} - \delta_{\{a,c,d\}} + \delta_{\{a,b,c,d\}}) \\
 &\quad - (\delta_{\{d\}} + \delta_{\{a,c\}} - \delta_{\{a,d\}} - \delta_{\{c,d\}} - \delta_{\{a,b,c\}} + \delta_{\{a,b,c,d\}})
 \end{aligned}$$

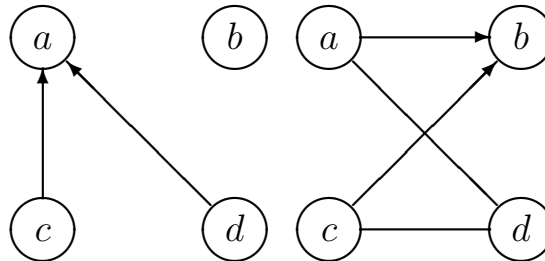

# Chapter 3

## Degree difference 3

### 3.4 Squared Euclidean length 4

#### 3.4.4 Number of nonzero values 4

##### 3.4.4.1 Differential imset (304)

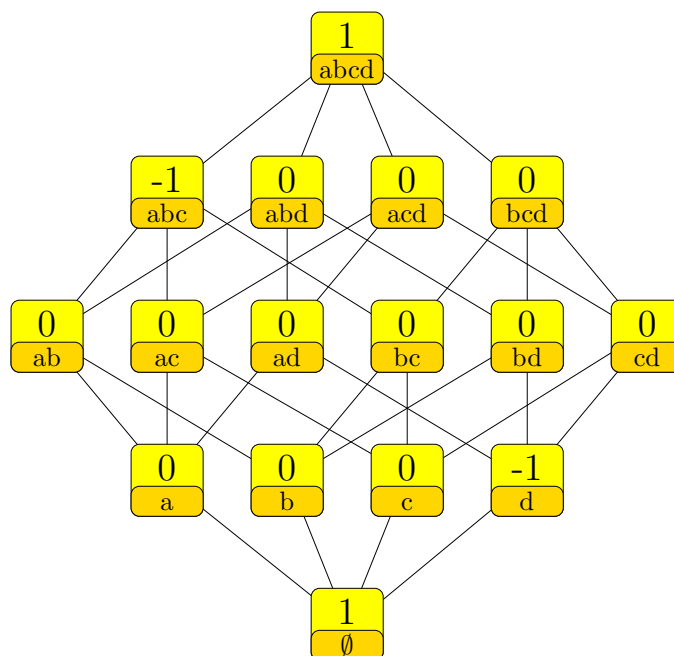

$$\begin{aligned}
 & \delta_{\emptyset} - \delta_{\{d\}} - \delta_{\{a,b,c\}} + \delta_{\{a,b,c,d\}} \\
 &= u_{\langle a,d|\emptyset \rangle} + u_{\langle c,d|ab \rangle} + u_{\langle b,d|a \rangle} \\
 &= (+3\delta_{\emptyset} - \delta_{\{a\}} - \delta_{\{b\}} - \delta_{\{c\}} - \delta_{\{d\}} + \delta_{\{a,b,c,d\}}) \\
 &\quad - (+2\delta_{\emptyset} - \delta_{\{a\}} - \delta_{\{b\}} - \delta_{\{c\}} + \delta_{\{a,b,c\}})
 \end{aligned}$$

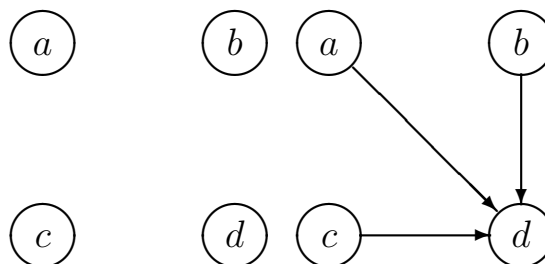

### 3.6 Squared Euclidean length 6

#### 3.6.6 Number of nonzero values 6

##### 3.6.6.1 Differential inset (305)

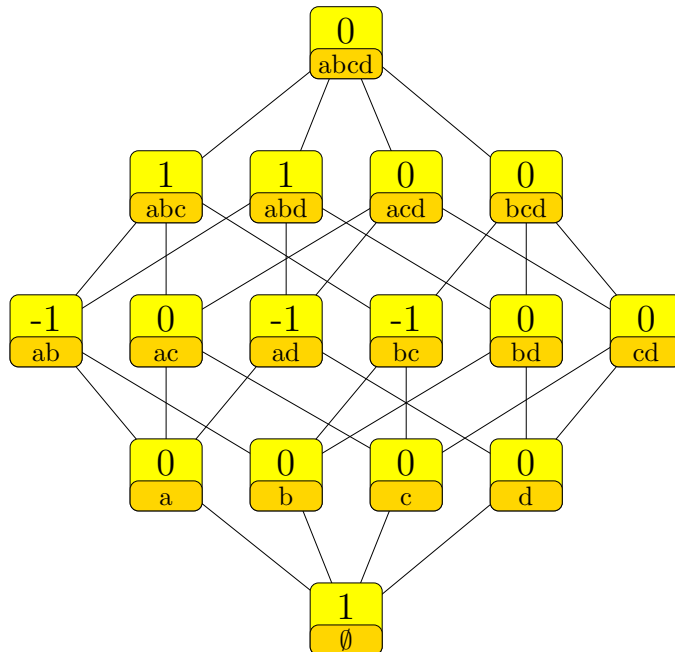

$$\begin{aligned}
 & \delta_{\emptyset} - \delta_{\{a,b\}} - \delta_{\{a,d\}} - \delta_{\{b,c\}} + \delta_{\{a,b,c\}} + \delta_{\{a,b,d\}} \\
 &= u_{\langle a,b|\emptyset \rangle} + u_{\langle b,d|a \rangle} + u_{\langle a,c|b \rangle} \\
 &= (\delta_{\emptyset} - \delta_{\{a,d\}} - \delta_{\{b,c\}} + \delta_{\{a,b,c,d\}}) \\
 &\quad - (\delta_{\{a,b\}} - \delta_{\{a,b,c\}} - \delta_{\{a,b,d\}} + \delta_{\{a,b,c,d\}})
 \end{aligned}$$

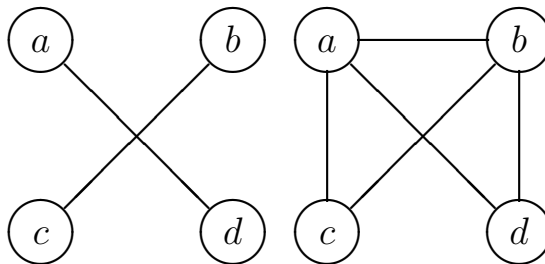

3.6.6.2 Differential imset (306)

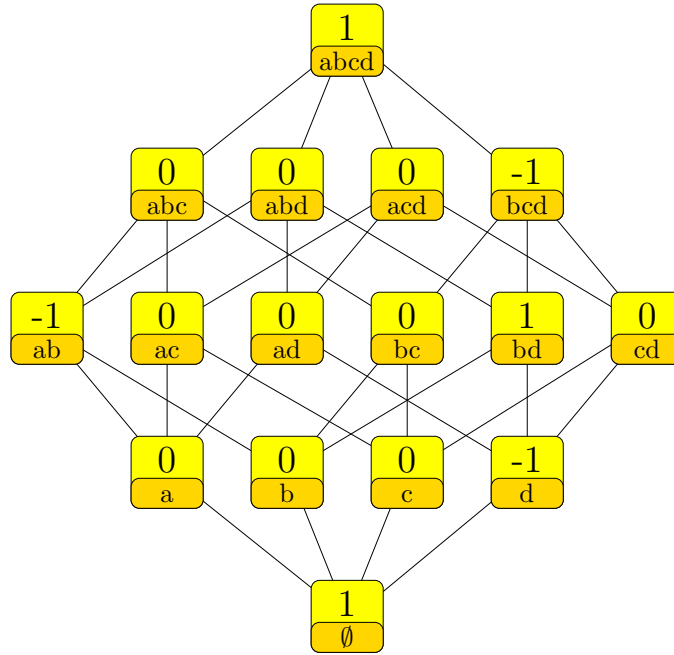

$$\begin{aligned}
 & \delta_\emptyset - \delta_{\{d\}} - \delta_{\{a,b\}} + \delta_{\{b,d\}} - \delta_{\{b,c,d\}} + \delta_{\{a,b,c,d\}} \\
 &= u_{\langle a,d|\emptyset \rangle} + u_{\langle a,c|bd \rangle} + u_{\langle b,d|a \rangle} \\
 &= (\delta_\emptyset - \delta_{\{a,b\}} - \delta_{\{c,d\}} + \delta_{\{a,b,c,d\}}) \\
 &\quad - (\delta_{\{d\}} - \delta_{\{b,d\}} - \delta_{\{c,d\}} + \delta_{\{b,c,d\}})
 \end{aligned}$$

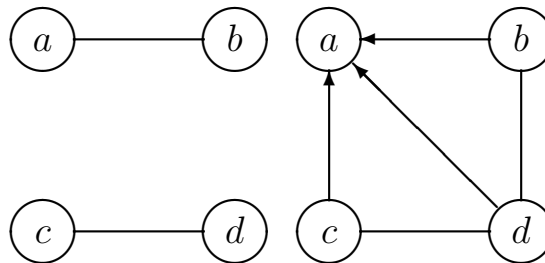

### 3.8 Squared Euclidean length 8

#### 3.8.8 Number of nonzero values 8

##### 3.8.8.1 Differential inset (307)

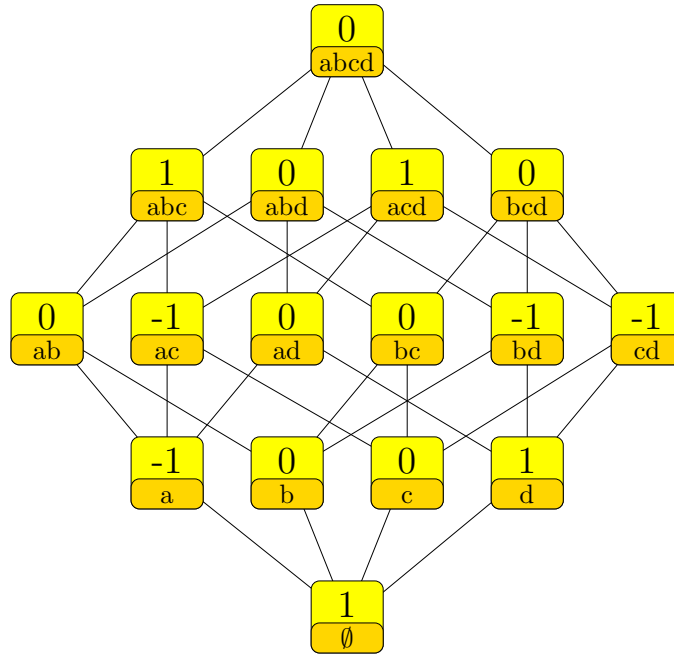

$$\begin{aligned}
 & \delta_{\emptyset} - \delta_{\{a\}} + \delta_{\{d\}} - \delta_{\{a,c\}} - \delta_{\{b,d\}} - \delta_{\{c,d\}} + \delta_{\{a,b,c\}} + \delta_{\{a,c,d\}} \\
 &= u_{\langle a,b|\emptyset \rangle} - u_{\langle b,d|ac \rangle} + u_{\langle a,d|bc \rangle} + u_{\langle a,c|b \rangle} + u_{\langle b,c|d \rangle} \\
 &= (\delta_{\emptyset} - \delta_{\{a\}} + \delta_{\{d\}} - \delta_{\{b,d\}} - \delta_{\{c,d\}} + \delta_{\{a,b,c,d\}}) \\
 &\quad - (\delta_{\{a,c\}} - \delta_{\{a,b,c\}} - \delta_{\{a,c,d\}} + \delta_{\{a,b,c,d\}})
 \end{aligned}$$

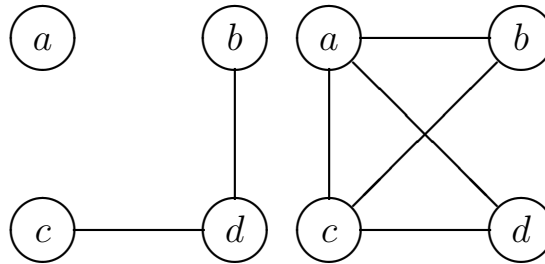

3.8.8.2 Differential inset (308)

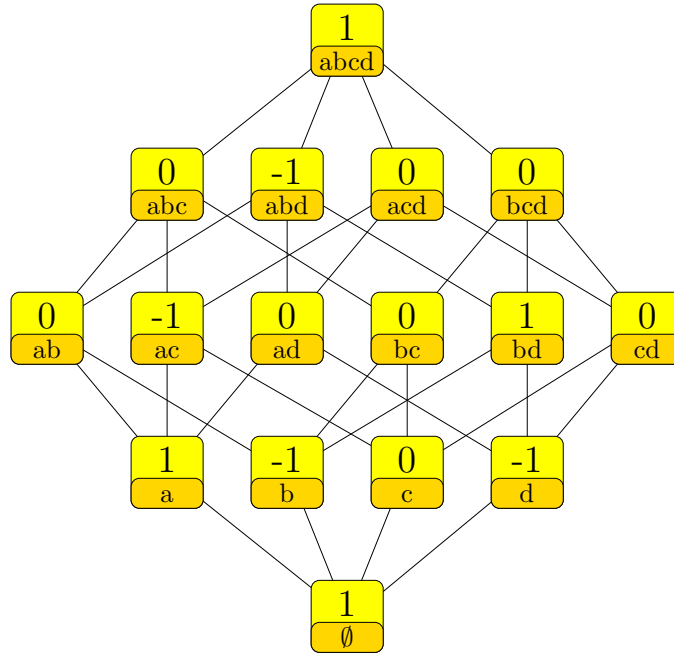

$$\begin{aligned}
 & \delta_{\emptyset} + \delta_{\{a\}} - \delta_{\{b\}} - \delta_{\{d\}} - \delta_{\{a,c\}} + \delta_{\{b,d\}} - \delta_{\{a,b,d\}} + \delta_{\{a,b,c,d\}} \\
 &= u_{\langle b,d|\emptyset \rangle} + u_{\langle c,d|ab \rangle} + u_{\langle b,c|a \rangle} \\
 &= (\delta_{\emptyset} + \delta_{\{a\}} - \delta_{\{b\}} - \delta_{\{a,c\}} - \delta_{\{a,d\}} + \delta_{\{a,b,c,d\}}) \\
 &\quad - (\delta_{\{d\}} - \delta_{\{a,d\}} - \delta_{\{b,d\}} + \delta_{\{a,b,d\}})
 \end{aligned}$$

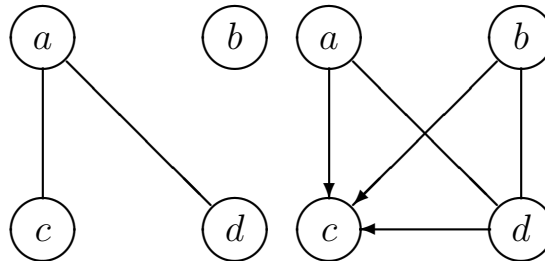

### 3.10 Squared Euclidean length 10

#### 3.10.7 Number of nonzero values 7

##### 3.10.7.1 Differential imset (309)

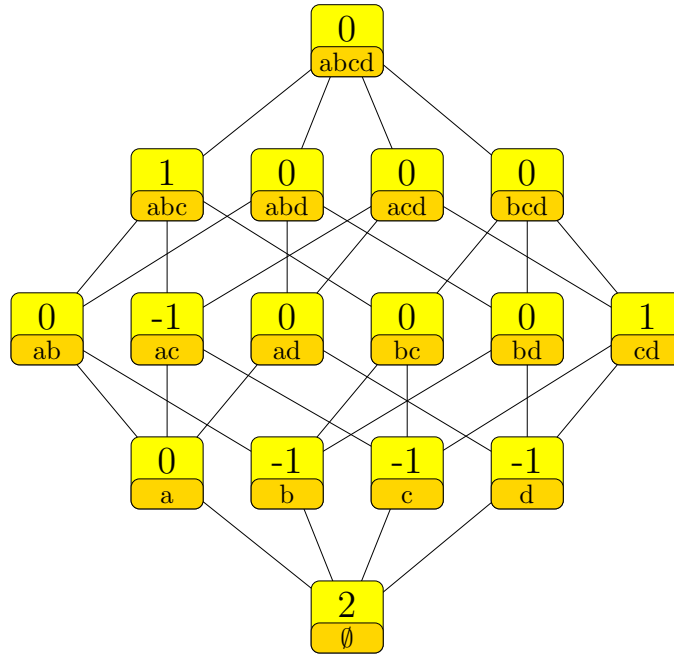

$$\begin{aligned}
 &+2\delta_\emptyset - \delta_{\{b\}} - \delta_{\{c\}} - \delta_{\{d\}} - \delta_{\{a,c\}} + \delta_{\{c,d\}} + \delta_{\{a,b,c\}} \\
 &= u_{\langle a,b|\emptyset \rangle} + u_{\langle c,d|\emptyset \rangle} + u_{\langle b,c|a \rangle} \\
 &= (+2\delta_\emptyset - \delta_{\{b\}} - \delta_{\{c\}} - \delta_{\{a,d\}} + \delta_{\{a,b,c,d\}}) \\
 &\quad - (\delta_{\{d\}} + \delta_{\{a,c\}} - \delta_{\{a,d\}} - \delta_{\{c,d\}} - \delta_{\{a,b,c\}} + \delta_{\{a,b,c,d\}})
 \end{aligned}$$

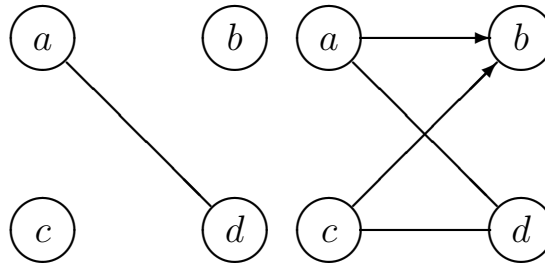



3.10.7.2 Differential imset (310)

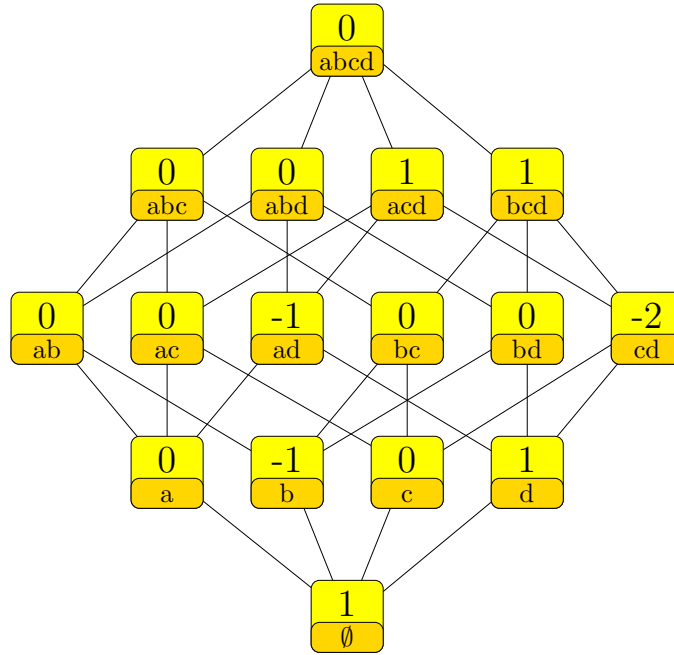

$$\begin{aligned}
 & \delta_{\emptyset} - \delta_{\{b\}} + \delta_{\{d\}} - \delta_{\{a,d\}} - 2\delta_{\{c,d\}} + \delta_{\{a,c,d\}} + \delta_{\{b,c,d\}} \\
 &= u_{\langle b,c|\emptyset \rangle} + u_{\langle a,c|d \rangle} + u_{\langle b,d|c \rangle} \\
 &= (\delta_{\emptyset} - \delta_{\{b\}} + \delta_{\{d\}} - \delta_{\{a,d\}} - \delta_{\{c,d\}} + \delta_{\{a,b,c,d\}}) \\
 &\quad - (\delta_{\{c,d\}} - \delta_{\{a,c,d\}} - \delta_{\{b,c,d\}} + \delta_{\{a,b,c,d\}})
 \end{aligned}$$

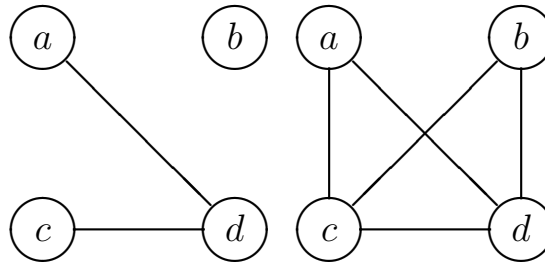

### 3.12 Squared Euclidean length 12

#### 3.12.9 Number of nonzero values 9

##### 3.12.9.1 Differential imset (311)

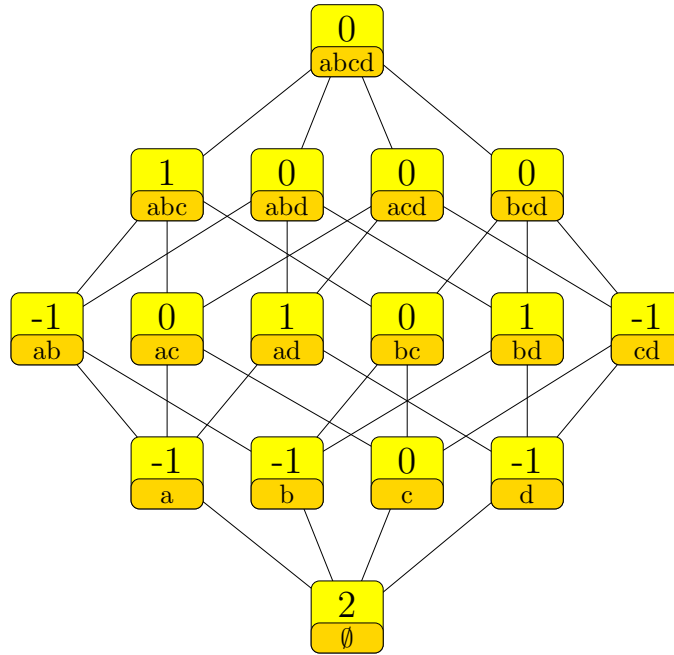

$$\begin{aligned}
 &+2\delta_\emptyset - \delta_{\{a\}} - \delta_{\{b\}} - \delta_{\{d\}} - \delta_{\{a,b\}} + \delta_{\{a,d\}} + \delta_{\{b,d\}} - \delta_{\{c,d\}} + \delta_{\{a,b,c\}} \\
 &= u_{\langle a,c|\emptyset \rangle} + u_{\langle a,d|\emptyset \rangle} + u_{\langle b,d|\emptyset \rangle} - u_{\langle c,d|\emptyset \rangle} + u_{\langle b,c|a \rangle} \\
 &= (+2\delta_\emptyset - \delta_{\{a\}} - \delta_{\{b\}} - \delta_{\{c,d\}} + \delta_{\{a,b,c,d\}}) \\
 &\quad - (\delta_{\{d\}} + \delta_{\{a,b\}} - \delta_{\{a,d\}} - \delta_{\{b,d\}} - \delta_{\{a,b,c\}} + \delta_{\{a,b,c,d\}})
 \end{aligned}$$

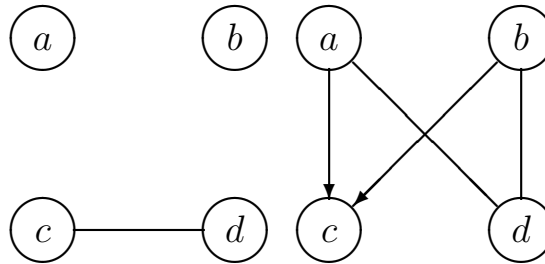

3.12.9.2 Differential imset (312)

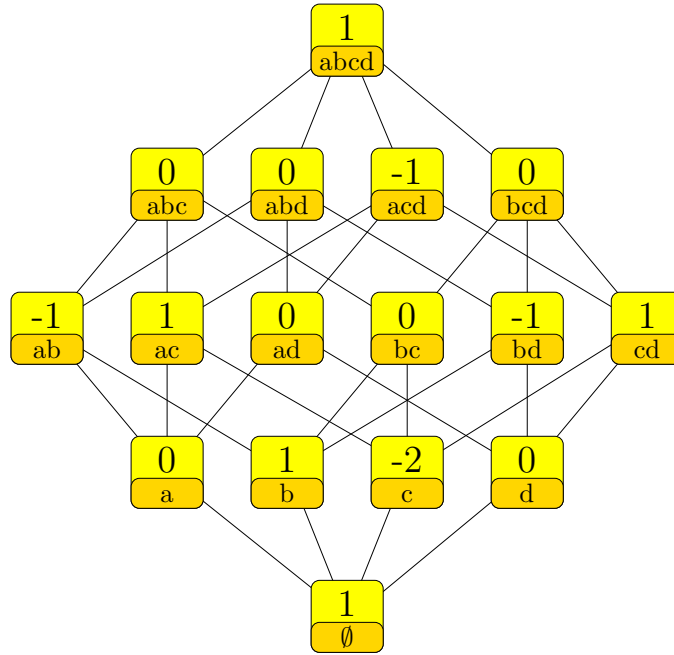

$$\begin{aligned}
 & \delta_{\emptyset} + \delta_{\{b\}} - 2\delta_{\{c\}} - \delta_{\{a,b\}} + \delta_{\{a,c\}} - \delta_{\{b,d\}} + \delta_{\{c,d\}} - \delta_{\{a,c,d\}} + \delta_{\{a,b,c,d\}} \\
 &= u_{\langle a,c|\emptyset \rangle} + u_{\langle c,d|ab \rangle} + u_{\langle b,c|a \rangle} + u_{\langle a,d|b \rangle} - u_{\langle a,d|c \rangle} \\
 &= (\delta_{\emptyset} + \delta_{\{b\}} - \delta_{\{c\}} - \delta_{\{a,b\}} - \delta_{\{b,d\}} + \delta_{\{a,b,c,d\}}) \\
 &\quad - (\delta_{\{c\}} - \delta_{\{a,c\}} - \delta_{\{c,d\}} + \delta_{\{a,c,d\}})
 \end{aligned}$$

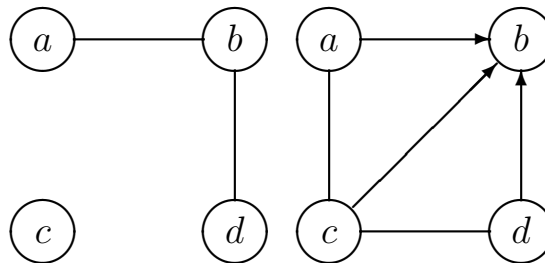

### 3.14 Squared Euclidean length 14

#### 3.14.8 Number of nonzero values 8

##### 3.14.8.1 Differential imset (313)

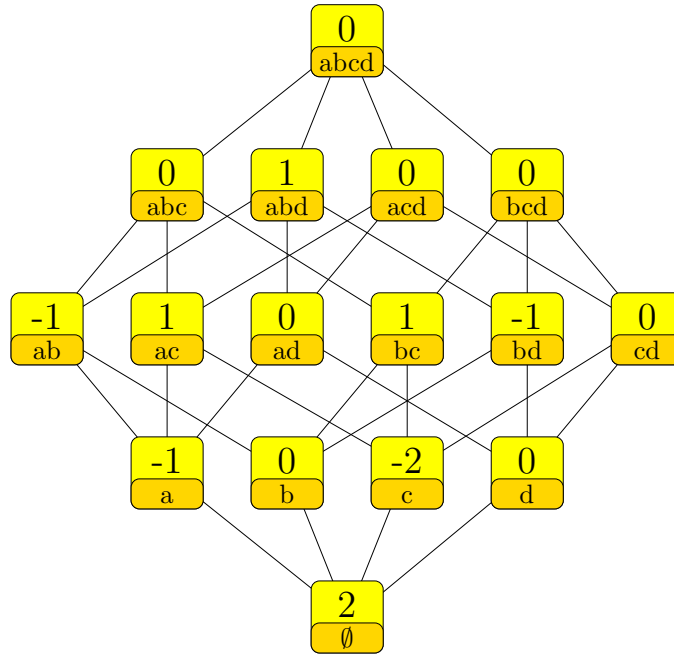

$$\begin{aligned}
 &+2\delta_\emptyset - \delta_{\{a\}} - 2\delta_{\{c\}} - \delta_{\{a,b\}} + \delta_{\{a,c\}} + \delta_{\{b,c\}} - \delta_{\{b,d\}} + \delta_{\{a,b,d\}} \\
 &= u_{\langle a,c|\emptyset \rangle} + u_{\langle b,c|\emptyset \rangle} + u_{\langle a,d|b \rangle} \\
 &= (+2\delta_\emptyset - \delta_{\{a\}} - \delta_{\{c\}} - \delta_{\{b,d\}} + \delta_{\{a,b,c,d\}}) \\
 &\quad - (\delta_{\{c\}} + \delta_{\{a,b\}} - \delta_{\{a,c\}} - \delta_{\{b,c\}} - \delta_{\{a,b,d\}} + \delta_{\{a,b,c,d\}})
 \end{aligned}$$

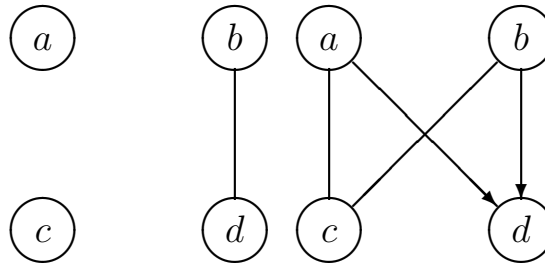

3.14.11 Number of nonzero values 11

3.14.11.1 Differential imset (314)

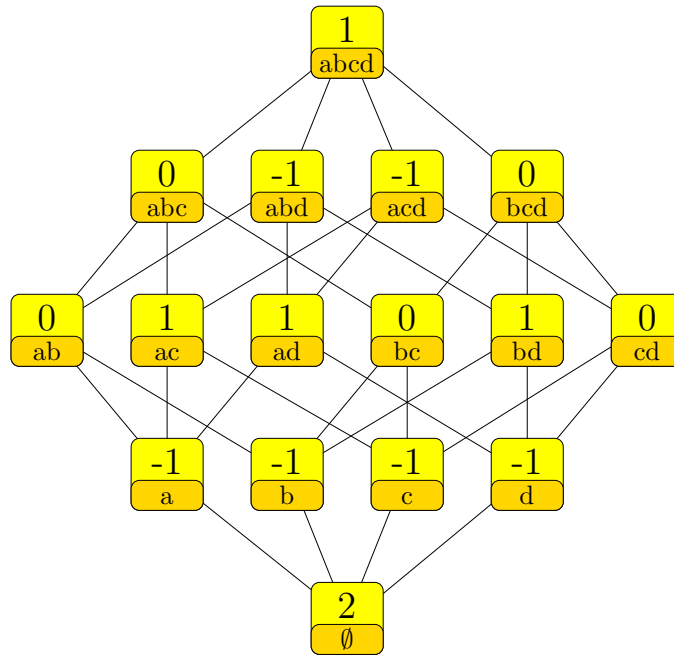

$$\begin{aligned}
 &+2\delta_{\emptyset} - \delta_{\{a\}} - \delta_{\{b\}} - \delta_{\{c\}} - \delta_{\{d\}} + \delta_{\{a,c\}} + \delta_{\{a,d\}} + \delta_{\{b,d\}} - \delta_{\{a,b,d\}} - \delta_{\{a,c,d\}} + \delta_{\{a,b,c,d\}} \\
 &= u_{\langle a,c|\emptyset\rangle} + u_{\langle b,d|\emptyset\rangle} + u_{\langle b,c|ad\rangle} \\
 &= (+2\delta_{\emptyset} - \delta_{\{b\}} - \delta_{\{c\}} - \delta_{\{d\}} + \delta_{\{b,d\}} - \delta_{\{a,b,d\}} + \delta_{\{a,b,c,d\}}) \\
 &\quad - (\delta_{\{a\}} - \delta_{\{a,c\}} - \delta_{\{a,d\}} + \delta_{\{a,c,d\}})
 \end{aligned}$$

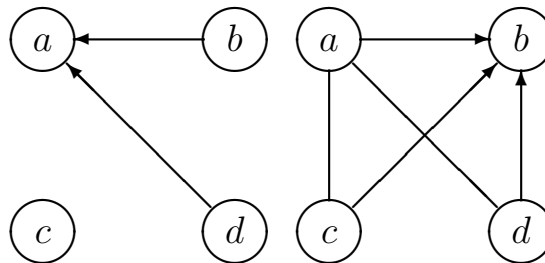

### 3.16 Squared Euclidean length 16

#### 3.16.7 Number of nonzero values 7

##### 3.16.7.1 Differential imset (315)

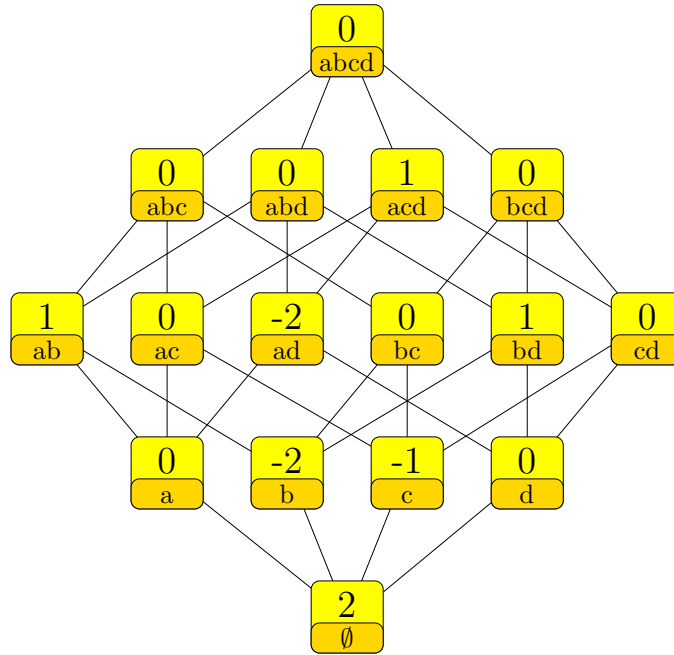

$$\begin{aligned}
 &+2\delta_\emptyset - 2\delta_{\{b\}} - \delta_{\{c\}} + \delta_{\{a,b\}} - 2\delta_{\{a,d\}} + \delta_{\{b,d\}} + \delta_{\{a,c,d\}} \\
 &= u_{\langle a,b|\emptyset \rangle} + u_{\langle a,c|\emptyset \rangle} - u_{\langle a,d|\emptyset \rangle} + u_{\langle b,d|\emptyset \rangle} + u_{\langle c,d|a \rangle} \\
 &= (+2\delta_\emptyset - \delta_{\{b\}} - \delta_{\{c\}} - \delta_{\{a,d\}} + \delta_{\{a,b,c,d\}}) \\
 &\quad - (\delta_{\{b\}} - \delta_{\{a,b\}} + \delta_{\{a,d\}} - \delta_{\{b,d\}} - \delta_{\{a,c,d\}} + \delta_{\{a,b,c,d\}})
 \end{aligned}$$

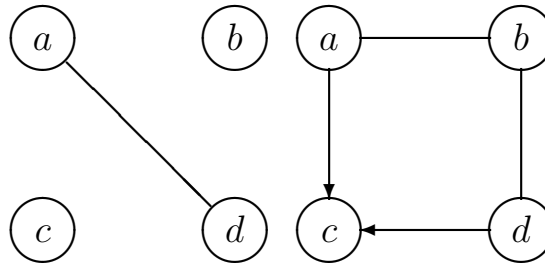

3.16.10 Number of nonzero values 10

3.16.10.1 Differential imset (316)

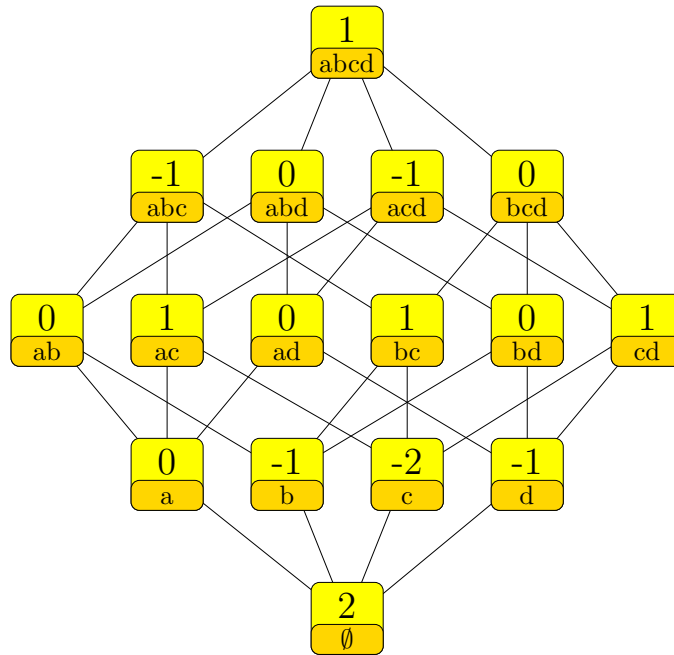

$$\begin{aligned}
 &+2\delta_\emptyset - \delta_{\{b\}} - 2\delta_{\{c\}} - \delta_{\{d\}} + \delta_{\{a,c\}} + \delta_{\{b,c\}} + \delta_{\{c,d\}} - \delta_{\{a,b,c\}} - \delta_{\{a,c,d\}} + \delta_{\{a,b,c,d\}} \\
 &= u_{\langle b,c|\emptyset\rangle} + u_{\langle c,d|\emptyset\rangle} + u_{\langle b,d|ac\rangle} \\
 &= (+2\delta_\emptyset - \delta_{\{b\}} - \delta_{\{c\}} - \delta_{\{d\}} + \delta_{\{c,d\}} - \delta_{\{a,c,d\}} + \delta_{\{a,b,c,d\}}) \\
 &\quad - (\delta_{\{c\}} - \delta_{\{a,c\}} - \delta_{\{b,c\}} + \delta_{\{a,b,c\}})
 \end{aligned}$$

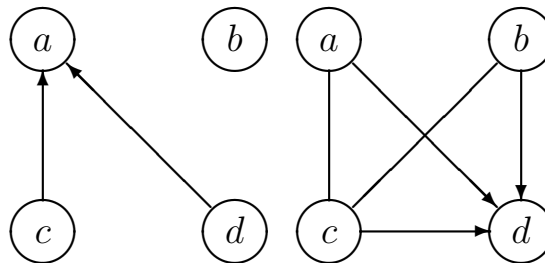

3.16.10.2 Differential imset (317)

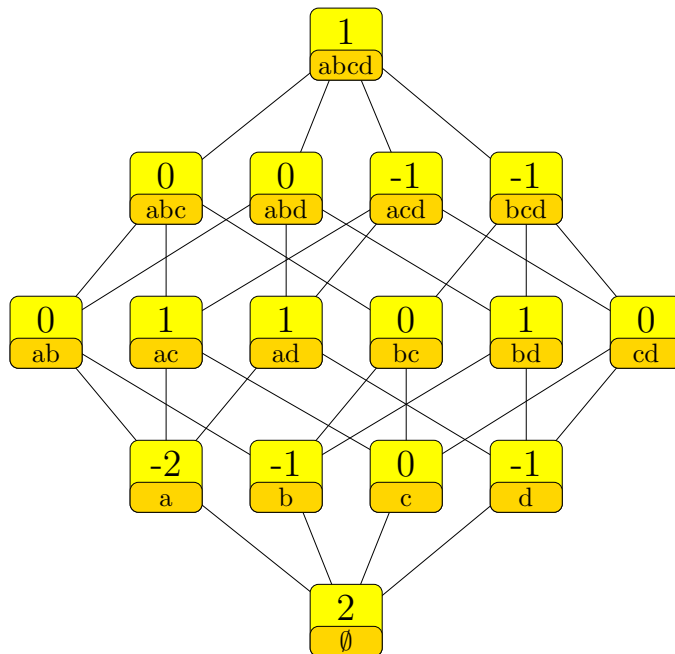

$$\begin{aligned}
 &+2\delta_\emptyset - 2\delta_{\{a\}} - \delta_{\{b\}} - \delta_{\{d\}} + \delta_{\{a,c\}} + \delta_{\{a,d\}} + \delta_{\{b,d\}} - \delta_{\{a,c,d\}} - \delta_{\{b,c,d\}} + \delta_{\{a,b,c,d\}} \\
 &= u_{\langle a,b|\emptyset \rangle} + u_{\langle a,d|\emptyset \rangle} + u_{\langle a,c|bd \rangle} + u_{\langle b,d|a \rangle} - u_{\langle c,d|a \rangle} \\
 &= (+2\delta_\emptyset - \delta_{\{a\}} - \delta_{\{b\}} - \delta_{\{d\}} + \delta_{\{b,d\}} - \delta_{\{b,c,d\}} + \delta_{\{a,b,c,d\}}) \\
 &\quad - (\delta_{\{a\}} - \delta_{\{a,c\}} - \delta_{\{a,d\}} + \delta_{\{a,c,d\}})
 \end{aligned}$$

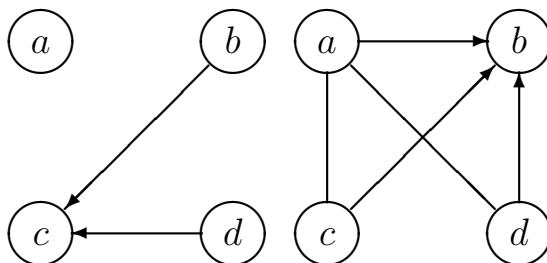



### 3.18 Squared Euclidean length 18

#### 3.18.9 Number of nonzero values 9

##### 3.18.9.1 Differential imset (318)

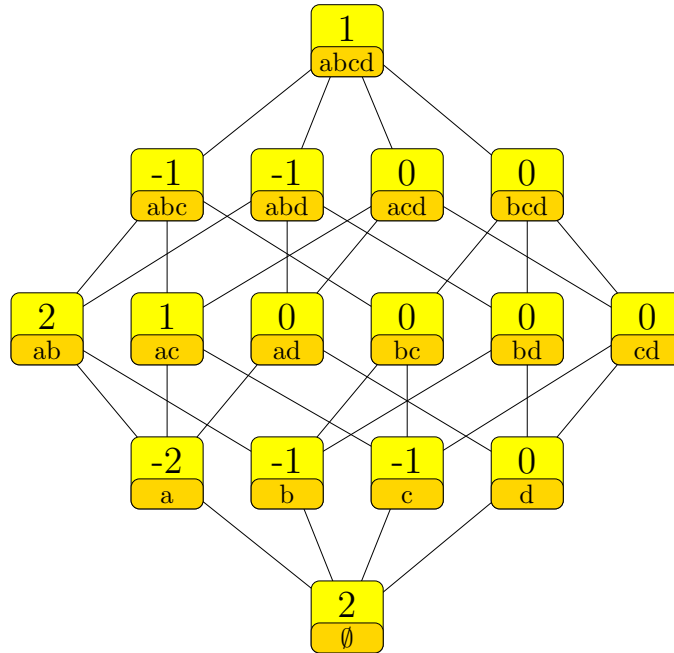

$$\begin{aligned}
 &+2\delta_{\emptyset} - 2\delta_{\{a\}} - \delta_{\{b\}} - \delta_{\{c\}} + 2\delta_{\{a,b\}} + \delta_{\{a,c\}} - \delta_{\{a,b,c\}} - \delta_{\{a,b,d\}} + \delta_{\{a,b,c,d\}} \\
 &= u_{\langle a,b|\emptyset \rangle} + u_{\langle a,c|\emptyset \rangle} + u_{\langle c,d|ab \rangle} \\
 &= (+2\delta_{\emptyset} - \delta_{\{a\}} - \delta_{\{b\}} - \delta_{\{c\}} + \delta_{\{a,b\}} - \delta_{\{a,b,d\}} + \delta_{\{a,b,c,d\}}) \\
 &\quad - (\delta_{\{a\}} - \delta_{\{a,b\}} - \delta_{\{a,c\}} + \delta_{\{a,b,c\}})
 \end{aligned}$$

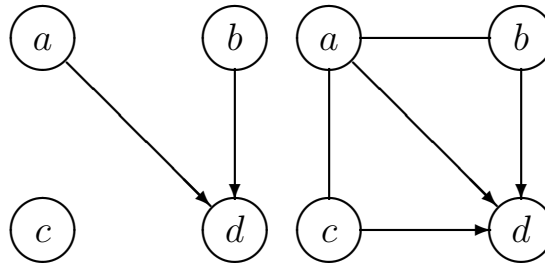

### 3.20 Squared Euclidean length 20

#### 3.20.8 Number of nonzero values 8

##### 3.20.8.1 Differential imset (319)

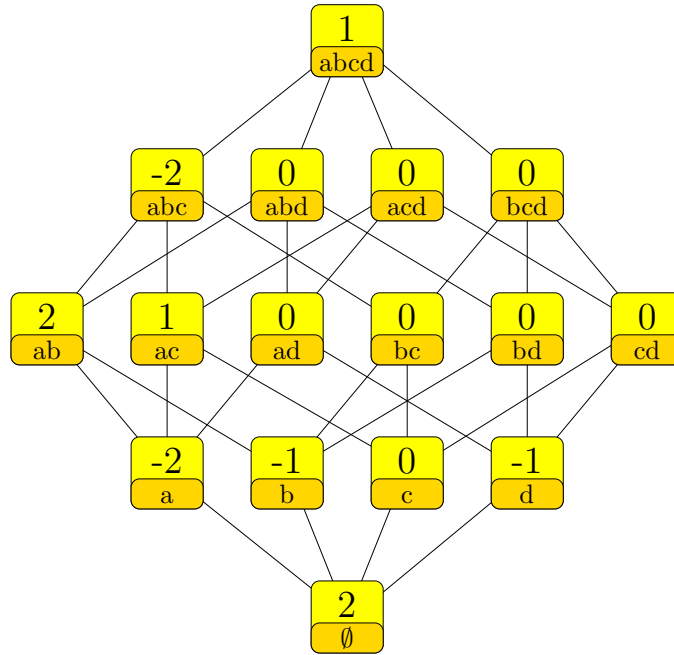

$$\begin{aligned}
 &+2\delta_\emptyset - 2\delta_{\{a\}} - \delta_{\{b\}} - \delta_{\{d\}} + 2\delta_{\{a,b\}} + \delta_{\{a,c\}} - 2\delta_{\{a,b,c\}} + \delta_{\{a,b,c,d\}} \\
 &= u_{\langle a,b|\emptyset\rangle} + u_{\langle a,d|\emptyset\rangle} + u_{\langle c,d|ab\rangle} - u_{\langle b,c|a\rangle} + u_{\langle b,d|a\rangle} \\
 &= (+2\delta_\emptyset - \delta_{\{a\}} - \delta_{\{b\}} - \delta_{\{d\}} + \delta_{\{a,b\}} - \delta_{\{a,b,c\}} + \delta_{\{a,b,c,d\}}) \\
 &\quad - (\delta_{\{a\}} - \delta_{\{a,b\}} - \delta_{\{a,c\}} + \delta_{\{a,b,c\}})
 \end{aligned}$$

